

Elite Gourmet

SINGLE CUP COFFEE MAKER

MODEL: EHC111A/EHC111A#

INSTRUCTION MANUAL

Before operating your new appliance, please read all instructions carefully and keep for future reference.



Questions? Elite's customer service team is ready to help.
For more Elite products, visit us at shopelitegourmet.com.



TABLE OF CONTENTS

IMPORTANT SAFEGUARDS	2
SHORT CORD PURPOSE	4
POLARIZED PLUG	4
PARTS IDENTIFICATION	5
BEFORE FIRST USE	6
HOW TO USE	6
CLEANING AND MAINTENANCE	7
WARRANTY POLICY	8
RETURN INSTRUCTIONS	9

IMPORTANT SAFEGUARDS

The Elite Brand takes consumer safety very seriously. Products are designed and manufactured with our valued consumers' safety in mind. Additionally, we ask that you exercise a level of caution when using any electrical appliance by following all instructions and important safeguards.

READ ALL INSTRUCTIONS BEFORE USE AND SAVE FOR FUTURE REFERENCE.

WARNING: When using electrical appliances, basic safety precautions should always be followed as below:

1. This coffee maker is intended for indoor, household, non-commercial use for brewing coffee. Do not use the coffee maker for any other purpose.
2. Keep the coffee maker out of reach from children and pets. This coffee maker is not intended for use by children. Extra caution is necessary when using this product near children.
3. Never leave the coffee maker unattended while it is in use. Always unplug the coffee maker from the electrical outlet when storing.
4. Always operate the coffee maker on a flat, level, and stable surface.
5. Do not place the coffee maker in areas or on surfaces (for example: carpets) that may be damaged by water, heat, or moisture. We will not be liable for any water-related damage that occurs during the use of this product.
6. Do not place the coffee maker on or near gas or electric burners. Do not place the coffee maker inside of, or on top of, a microwave oven or conventional oven.
7. Do not operate this product or any other electrical product in the presence of explosives and/or flammable fumes.
8. Use only product manufacturer's attachments with this product; otherwise, a risk of fire, electrical shock, or personal injury may result.
9. Keep the power cord and product away from heated surfaces.
10. Do not touch hot surfaces of this product. Always touch the product using the handle and knobs. Never move the coffee maker when it is in use or while it contains hot liquid. Allow the unit to cool completely before handling. Do not touch the mug or other hot surfaces of the coffee maker.
11. Do not operate the coffee maker if it has a damaged power cord or plug. Do not operate the coffee maker if it shows signs of damage. This product has no user-serviceable parts. Do not attempt to repair this product yourself. Only qualified service personnel should perform any repairs.
12. Do not remove bottom cover of coffee maker, as there may be a risk of fire or electrical shock.
13. Do not immerse the power cord or plug in, or otherwise expose them to, water or other liquids, as an electrocution hazard may result.
14. Do not allow the power cord to hang over the edge of a table or counter where it may get tripped over or pulled.
15. To disconnect product from an electrical outlet, pull directly on the plug; do not pull on the power cord.
16. Never operate the coffee maker without the mug in place on the warming plate.
17. Scalding may occur if the lid is removed during the brewing cycle.

IMPORTANT SAFEGUARDS (cont.)

18. Do not open the lid of the water reservoir or the filter basket while the coffee maker is brewing. Allow the filter basket to cool completely before removing it
19. This product is for indoor use only. Do not use this product outdoors, as an electrocution hazard exists.
20. Unplug from outlet when not in use and before cleaning. Cooling the appliance before putting on or removing parts and before cleaning the appliance.

**SAVE THESE INSTRUCTIONS.
THIS PRODUCT IS FOR
HOUSEHOLD USE ONLY.**

SHORT CORD PURPOSE

Note: A short power cord is provided to reduce the risk of personal injury resulting from becoming entangled in or tripping over a long cord.

Longer power-supply cords or extension cords may be used if care is exercised in their use.

If an extension cord is used: (1) the marked electrical rating of the extension cord should be at least as great as the electrical rating of the product; (2) the extension cord should be arranged so that it will not drape over the counter top or tabletop where it can unintentionally be pulled on or tripped over by children or pets.

POLARIZED PLUG

If this appliance is equipped with a *polarized plug* (one blade is wider than the other), please follow the below instructions:

To reduce the risk of electrical shock, this plug is intended to fit into a polarized outlet only one way. If you are unable to fit the plug into the electrical outlet, try reversing the plug.

If the plug still does not fit, contact a qualified electrician. Never use the plug with an extension cord unless the plug can be fully inserted into the extension cord. Do not alter the plug of the product or any extension cord being used with this product. Do not attempt to defeat the safety purpose of the polarized plug.

PARTS IDENTIFICATION

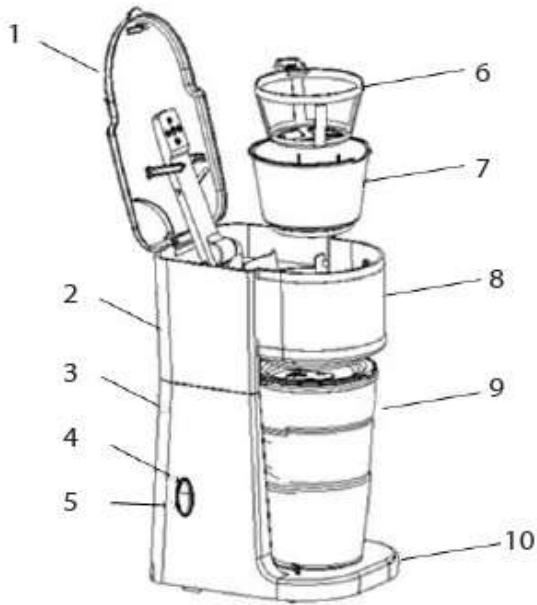

- | | |
|--------------------|-------------------------|
| 1. Lid | 6. Reusable Mesh Filter |
| 2. Water Tank | 7. Filter Basket |
| 3. Main Housing | 8. Brewing Chamber |
| 4. Indicator Light | 9. Mug |
| 5. Power Button | 10. Base |

BEFORE FIRST USE

1. Unpack the appliance and all parts. Remove all packaging materials, including any stickers or labels.
2. Before the first use, please check if all the parts of the appliance are in good condition. If not, please contact the seller or manufacturer.
3. Clean the interior surface of the coffee maker with a damp cloth. Wipe dry with a soft cloth immediately. Do not use abrasive materials. Wipe down the exterior with a soft dry cloth.
4. NEVER IMMERSER APPLIANCE OR CORD IN WATER OR ANY OTHER LIQUID.
5. Position the coffee maker on a stable, dry, level, heat-resistant surface near an electrical outlet.
6. Unroll the electrical cord.
7. Operate the coffee maker on a separate outlet and circuit from other appliances to avoid overloading the circuit.
8. It is recommended to run the coffee maker for one cycle with just plain water and no coffee to clean the internal parts of the coffee maker.

HOW TO USE

1. Make sure all parts are dry and that the unit is not plugged into an electrical outlet while filling with water and coffee grounds.
2. Pour in 14oz water into the water tank.
3. Open the lid and take out the filter. Put three tablespoons of finely ground coffee or four tablespoons of regular ground coffee into the filter and distribute it evenly.
4. Reinstall the filter into the filter basket and place the filter basket into the brewing chamber.
5. Close the water tank lid.
6. Put the mug without the lid onto the base
7. Plug the coffee maker into an electric outlet and Press the start button - the indicator light will turn on.
8. When the coffee is ready, the indicator light will turn off.
9. Allow all the hot coffee to drip from the brewing chamber into the mug before removing the mug.

Caution: Scalding may occur by open the water tank lid during the brewing.



NOTE:

- This coffee maker comes with a reusable mesh filter. A paper filter can't be used in place of reusable mesh filter.
- This coffee maker is NOT compatible with K-cups or capsules.



NOTE:

- Once the coffee maker starts the brewing it will remain on until the brewing cycle is complete. To interrupt or stop the brewing, disconnect the plug from the electrical outlet.
- Do not touch the warming plate as it is hot!
- Do not touch the lid during brewing.
- After brewing cycle is complete, wait a minimum of 10 minutes before taking out the filter basket to avoid any injury from hot steam.
- Make sure the filter is secured back in place before beginning to operate your coffeemaker.

HOW TO USE (cont.)

AFTER USE:

1. When the last drop has dripped out of the filter, the mug can be removed from the base.
2. DO NOT OPEN THE LID WHILE THE COFFEE MAKER IS IN OPERATION AS THIS COULD LEAD TO PERSONAL INJURY.
3. Switch the appliance off and unplug from the electrical outlet.
4. The indicator light will turn off.
5. Clean the filter by removing the coffee filter and the remaining coffee grounds.
6. If the second mug of coffee is required, please switch off the appliance first. After cooling the appliance for 3 minutes, you can begin to brew again.

Warning: Always unplug the power cord from the electrical outlet and allow the product to cool completely before cleaning or storing.

BREWING THE SECOND MUG OF COFFEE:

Allow the coffeemaker to completely cool down (about three minutes) after the indicator light turns off. Rinse the mug and the mesh filter with water. Repeat the brewing procedure.

Warning: The water placed in the water reservoir may overheat if the coffeemaker does not cool down completely before reuse. This can cause steam to escape, resulting in a risk of burns and/or personal injury.



CAUTION:

Use extreme care when handling the mug after use as it will be very hot!



NOTE:

Attempting to start another brewing cycle before the coffee maker cools down completely may result in an incomplete cycle. The unit employs a thermal reset switch to prevent overheating and may shut down.

CLEANING & MAINTENANCE

Proper maintenance will ensure years of service of your appliance. Clean the appliance after every use following these steps:

1. Always remove the main plug from the wall socket and allow all parts to cool completely before cleaning the appliance.
2. Clean the housing and warming plate with a clean, damp cloth. Never immerse the unit in water or wash it directly in water.
3. Remove mug, mug lid, filter and the filter basket from the coffee maker.
4. Only the mug, mug lid and filter basket may be placed on the upper rack of a dishwasher for cleaning. Or hand washed in warm, soapy water. Rinse and dry. The filter must be wash by hand.
5. Ensure all parts are completely dry after washing and before use.
6. Store the coffee maker in a dry and clean place.
7. The parts may appear to fade by washed in a dishwasher.

DESCALING:

1. When de-scaling, operate the appliance twice using a mixture of one part white vinegar and one part water to fill the water reservoir tank and let unit run as usual.
2. Run the unit twice more with only water to rinse away the remaining scale and vinegar.



NOTE:

- Always use care to prevent damaging the filter mesh.
- Make sure the filter is secured back in place before beginning to operate your coffeemaker.
- Do not dry inside of water tank with a cloth as lint may remain.



CAUTION:

Never immerse the entire coffee maker in water or any other liquid!

LIMITED WARRANTY* ONE (1) YEAR
WARRANTY IS ONLY VALID WITH A DATED PROOF OF PURCHASE

PLEASE DO NOT RETURN TO STORE OF PURCHASE.

If you have any problems with this unit, contact Customer Service for support.

1. Your small kitchen appliance is warranted to the original purchaser to be free from any manufacturing defects under normal use and conditions for one (1) year, cord excluded. This Warranty applies only to the original purchaser of this product.
2. Retail stores/merchants selling this product do not have the right to alter, modify, or in any way revise the terms and conditions of the warranty.
3. If you use your appliance for household use and according to instructions, it should give you years of satisfactory service.
4. At its sole discretion, Maxi-Matic USA will either repair or replace the product found to be defective during the warranty period.
5. The repaired or replacement product will be in warranty for the remaining balance of the one-year warranty period and an additional one-month period.
6. Consumer's remorse is not an acceptable reason to return a product to our Service Center.
7. This limited warranty covers appliances purchased and used within the 50 U.S. states plus the District of Columbia and does NOT cover normal wear of parts or:
 - Damages caused by unreasonable use, neglect, normal wear and tear, commercial use, improper assembly or installation of product.
 - Damages caused in shipping.
 - Damages caused by replacement or resetting of house fuses or circuit breakers.
 - Defects other than manufacturing defects.
 - Breakage caused by misuse, abuse, accident, alteration, lack of proper care and maintenance, or incorrect current or voltage.
 - Lost or missing parts of the product. Parts will need to be purchased separately.
 - Damages of parts that are not electrical; i.e. cracked or broken plastic/glass, scratched/dented inner pots.
 - Damage from service or repair by unauthorized personnel.
 - Extended warranties purchased via a separate company or reseller.
 - Acts of nature such as fire, floods, hurricanes, tornadoes, etc.
8. **This warranty does not apply to re-manufactured merchandise.**

Maxi-Matic, USA shall not be liable for any incidental or consequential damages caused by the breach of any express or implied warranty. Apart from the extent prohibited by applicable law, any implied warranty of merchantability or fitness for a particular purpose is limited in time to the duration of the warranty.

*One Year Limited Warranty valid only in the 50 U.S. states plus the District of Columbia, excluding Puerto Rico and the Virgin Islands.

This warranty is effective only if the product is purchased and operated in the USA; product usage which is in violation of the written instructions provided with the unit will void this warranty. For international warranty, please contact the local distributor.

This warranty gives you special legal rights and you may also have other rights to which you are entitled which may vary by state, province, and/or jurisdiction.

**Any instruction or policy included in this manual may be subject to change at any time.

MAXI-MATIC, USA

18401 E. Arenth Ave. City of Industry, CA 91748

Visit: shopelitegourmet.com for Live Chat Support and Contact Us Form

RETURN INSTRUCTIONS

RETURNS:

- A. Any return of defective merchandise to the manufacturer must be processed accordingly by first contacting customer service (support@maxi-matic.com) to obtain an RA # (Return Authorization Number). We will not accept any returns of merchandise without an applicable RA #.
- B. **IMPORTANT RETURN INSTRUCTIONS.** Your Warranty depends on your following these instructions if you are returning the unit to Maxi-Matic, USA:
1. Carefully pack the item in its original carton or other suitable box with sufficient cushioning to avoid damage in shipping.
 2. Before packing your unit for return, be sure to enclose:
 - a) Your name, full address with zip code, daytime telephone number, and RA#,
 - b) A dated sales receipt or PROOF OF PURCHASE,
 - c) The model number of the unit and the problem you are having (Enclose in an envelope and tape directly to the unit before the box is sealed,) and
 - d) Any parts or accessories related to the problem.
 3. Maxi-Matic, USA recommends that you ship the package via UPS ground service for tracking purposes. **We cannot assume responsibility for lost or damaged products returned to us during incoming shipment.** For your protection, always carefully package the product for shipment and insure it with the carrier. C.O.D shipments cannot be accepted.
 4. **All return shipping charges must be prepaid by you.**
 5. Once your return has been received by our warehouse, Maxi-Matic, USA will repair or replace the product if it is defective in material or workmanship, subject to the conditions in paragraph B.
 6. **Maxi-Matic will pay the shipping charges to ship the repaired or replacement product back to you.**

Elite Gourmet

Elite Customer Service Center

Mail: Maxi-Matic, USA
18401 E. Arenth Ave
City of Industry, CA
91748-1227

Website: shopelitegourmet.com
Visit our website for Live Chat Support
& Contact Us Form
Register your product online



We take pride in the fact that Elite Gourmet products are continuously improving. To keep you well informed of these changes and to reduce paper consumption, we've included this QR code for you to scan and easily download the most recent updates to your product to your mobile device.

It's simple, just access your camera, point at the QR code & your mobile device will do the rest.



[elitebymaximatic](https://www.facebook.com/elitebymaximatic)



[@elite_by_maximatic](https://www.instagram.com/elite_by_maximatic)

Elite is a registered trademark of Maxi-Matic, USA.
Copyright Elite by Maxi-Matic.

Actual product may vary from the images/illustrations in this manual due to continual product improvement.

MODEL: EHC11A/EHC11A#