

PT-D200 User's Guide

Thank you for purchasing Brother's PT-D200! With your PT-D200, you can create labels for multiple applications. Select from the many frames, character sizes and styles to design beautiful custom labels. In addition, the variety of tape cartridges available allows you to print labels with different widths and exciting colors. For a complete list of tapes compatible with your label maker, visit us at: www.brother.com. Please read this guide, including all Precautions, before using this label maker. After reading this guide, keep it in a safe place.



Safety Precautions

WARNING Indicates a potentially hazardous situation which, if not avoided, could result in death or serious injuries.

- Follow these guidelines to avoid the risk of fire, burns, injury, electric shocks, rupture, overheating, abnormal odours or smoke.
- Always use the specified voltage and the suggested AC adapter (AD-24ESA/AD-24ESA/AD-24ESA/AD-24ESA-01/AD-24ESAW-01) for the label maker to prevent any damage or failure.
- Do not touch the label maker during a lightning storm.
- Do not use the label maker/AC adapter in places of high humidity such as bathrooms.
- Do not overload the power cord.
- Do not place heavy objects on, or damage the power cord or plug. Do not forcibly bend or pull the power cord. Always hold the AC adapter when disconnecting from the power outlet.
- Make sure that the plug is fully inserted to the power outlet. Do not use an outlet that is loose.
- Do not allow the label maker/AC adapter/power plug/batteries to get wet, for example, by handling them with wet hands or spilling beverages on to them.
- Since loss of eyesight may result when leaked fluid from batteries gets into your eyes, immediately rinse your eyes with a large amount of clean water, and then seek medical attention.
- Do not disassemble or modify the label maker/AC adapter/batteries.
- Do not allow a metal object to contact both the plus and minus ends of a battery.
- Do not use sharp objects, such as tweezers or a metallic pen, to change the batteries.
- Do not throw the batteries into fire or expose to heat.
- Disconnect the AC adapter and remove batteries immediately and stop using the label maker if you notice abnormal odor, heat, discoloration, deformation or anything unusual while using or storing it.
- Do not use a damaged or leaking battery as the fluid may get on your hands.
- Do not use a deformed or leaking battery or one whose label is damaged. There is a possibility of generating heat.

CAUTION

Indicates a potentially hazardous situation which, if not avoided, may result in minor or moderate injuries.

- Follow these guidelines to avoid personal injury, liquid leakage, burns or heat.
- When the label maker is not being used, store it out of the reach of children. In addition, do not allow children to put the label maker parts or labels in their mouths. If any object has been swallowed, seek medical attention.
- Do not touch metal parts around the print head immediately after printing.
- Do not touch the cutter blade.
- If leaked fluid from batteries gets on your skin or clothes, immediately rinse them with clean water.
- Remove the batteries and disconnect the AC adapter if you do not intend to use the label maker.
- Do not use a battery other than that specified. Do not use combinations of old and new batteries or combinations of different types, different charging levels, different manufacturers or different models. Do not insert a battery with its plus and minus ends reversed.
- Do not drop or hit the label maker/AC adapter.
- Do not press on the LCD display.
- Do not put your finger inside the label maker when you close the cassette cover.
- Before using Ni-MH rechargeable batteries, carefully read the instructions for the batteries and battery charger, and be sure to use them correctly.
- When using Ni-MH rechargeable batteries, charge the batteries with a specialized battery charger before using the batteries.

General Precautions

- Depending on the location, material, and environmental conditions, the label may unpeel or become irremovable, the color of the label may change or be transferred to other objects. Before applying the label, check the environmental conditions and the material.
- Do not use the label maker in any way or for any purpose not described in this guide. Doing so may result in accidents or damage the label maker.
- Use only Brother TZe tapes with the label maker. Do not use tapes that do not have the TZe mark.
- Only use a soft, dry cloth to clean the labeler; never use alcohol or other organic solvents.
- Use a soft wipe to clean the print head, never touch the print head.
- Do not put any foreign objects into the tape exit slot or AC adapter connector or battery compartment, etc.

Federal Communications Commission (FCC) Compliance Notice (For USA Only)
This equipment has been tested and found to comply with the limits for a Class B digital device, pursuant to Part 15 of the FCC Rules. These limits are designed to provide reasonable protection against harmful interference in a residential installation. This equipment generates, uses, and can radiate radio frequency energy and, if not installed and used in accordance with the instructions, may cause harmful interference to radio communications. However, there is no guarantee that interference will not occur in a particular installation. If this equipment does cause harmful interference to radio or television reception, which can be determined by turning the equipment off and on, the user is encouraged to try to correct the interference by one or more of the following measures:
- Reorient or relocate the receiving antenna.
- Increase the separation between the equipment and receiver.
- Connect the equipment into an outlet on a circuit different from that to which the receiver is connected.
- Consult the dealer or an experienced radio/TV technician for help.
Important: Changes or modifications not expressly approved by Brother Industries, Ltd. could void the user's authority to operate the equipment.

2 BASIC USAGE

Entering Text

You can enter a maximum of 80 characters and spaces for a text label, and 50 characters and spaces if using templates. To cancel any operation, press [Esc].

Switching Upper Case/Lower Case

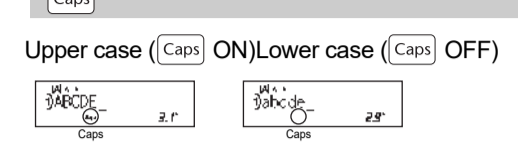

Creating Two-Line Tapes

Move the cursor to where you want to start the next line and press [Enter]. Use either 0.35" (9mm) or 0.47" (12mm) tape for two-line printing.

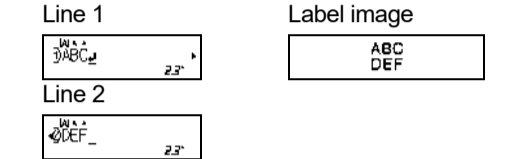

NOTE

- The return symbol (↵) appears when you press the Enter key.

Entering Tabs

- You can also set a tab by pressing [Tab].
- The tab symbol (|) appears when you insert a tab in the text.

Changing Tab Length

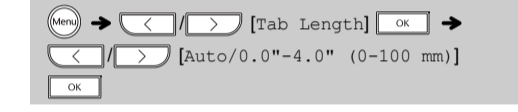

NOTE

- If you prefer to use the optional AC Adapter instead of using batteries:
1. Insert the Power Adapter cord into the AC Adapter Jack on the side of the label maker.
2. Insert the Power Adapter into a grounded AC electrical outlet.
When running a memory backup, we recommend using both batteries AND the optional Power Adapter, in the event that one or the other power method fails.

Printing Labels

Preview

- Pressing the Preview key (⏮) displays a preview of the label, and may differ from the actual one when printed.
- If the LCD cannot display all the text at once, press [Left] or [Right] to display the hidden text.
- Press [OK], [Enter], or [Esc] to exit Preview mode.

Feeding (Tape Feed)

- This function feeds approximately 1" (25mm) of blank tape.
- Do not pull the tape, as this may damage the Tape Cassette.

Printing

- Press [Print] to print the label.
- If you need only one copy of the label, press [OK] after you press [Print].
- You can print up to nine copies of each label.
- Press a number key to specify the number of copies you wish to print.
- DO NOT touch the Tape Cutter Lever while the message [Printing...] or [Feeding...] appears on the LCD.
- When printing ends, push the Tape Cutter Lever.
- To remove label backing, fold the label lengthwise (with the text facing inward), to expose the inside edges that run down the center of the tape backing. Peel and apply.

3 USING TEMPLATES

Name Label

Use Name Label templates to polish the look of your labels using one of our predesigned formats. Refer to the Name Label Templates table in this guide.

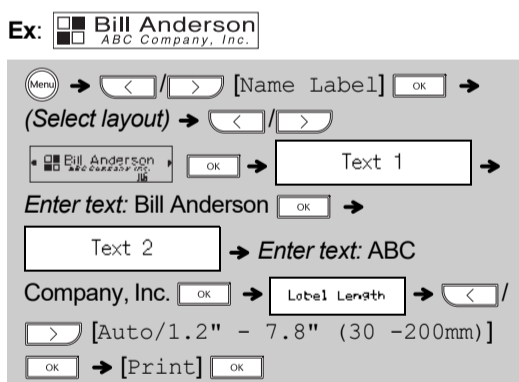

NOTE

- Depending on the format you have selected, the entire contents of your text may not be printed. For example, if you selected a fixed Label Length and the text is too long, an error message [Text Limit!] will appear.
- Templates cannot be edited.
- Only the highlighted symbols, shaded in the Basic Symbols / Pictograph Symbols table in this guide, can be used in Deco Mode.
- To clear all text, press [Shift] and [Clear]. When [Clear?] appears, press [OK] to clear. Press [Esc] to cancel.
- When you access templates, your most recent label created with a template opens automatically.
- Press [Esc] to return to the previous step.

Using Print Options

Numbering
You can print a series of up to nine labels using auto-numbering. Use this feature to automatically increase a selected number by 1 after each one is printed.
Ex: Print copies of a label containing a serial number (0123, 0124 and 0125)

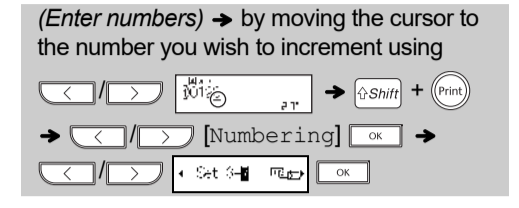

Select the highest number you wish to print when setting the number.
Mirror
Ex: To Mirror Print "J.SMITH", follow the instructions below after entering "J.SMITH".

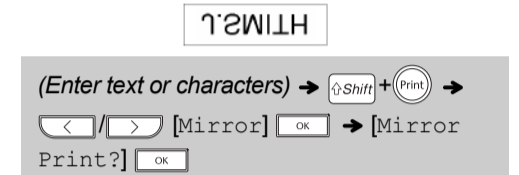

- Use clear tape when using this function, so the labels can be read correctly from the opposite side when attached on glass, windows, or other transparent surfaces.

1 GETTING STARTED

Installing Power Supply and Tape Cassette

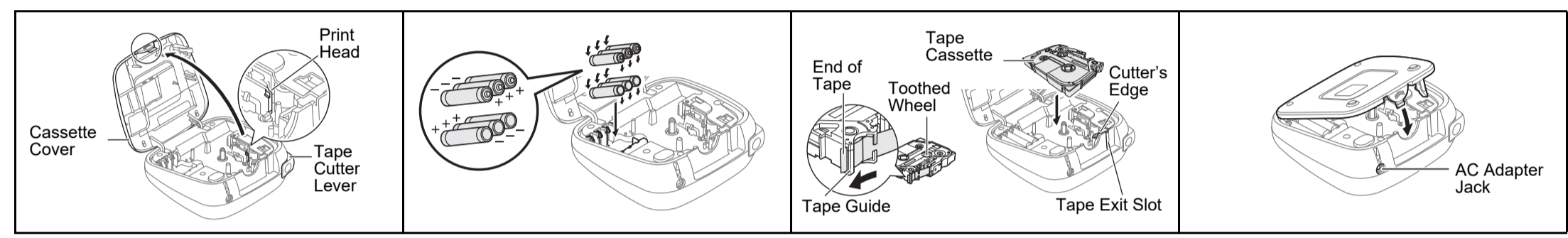

With the LCD facing down, open the Cassette Cover by pressing the grooved tab and pushing in the direction of the arrow, as illustrated. If a tape cassette is already installed, remove it by pulling it straight up.

When replacing batteries or tape cassettes, make sure the power is turned off. This label maker requires six (6) AAA alkaline batteries or six (6) fully charged Ni-MH batteries, not included.

Insert the Tape Cassette following the drawing marked inside the case. Gently press the Cassette into the label maker until it clicks into place.

Close the Cassette Cover and gently press until it clicks into place.

LCD and Keyboard

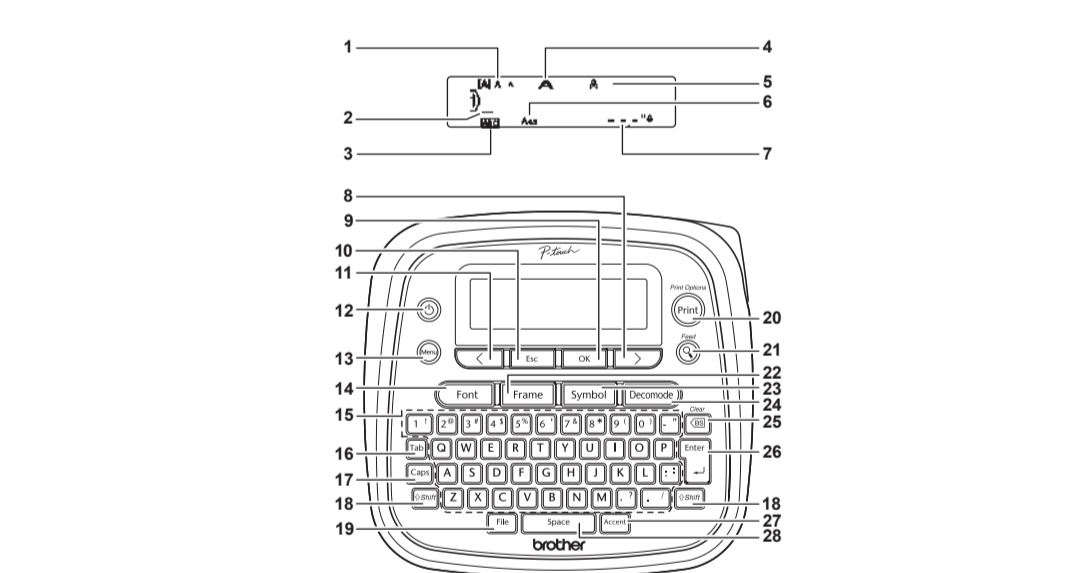

- 1. Size
2. Cursor
3. Underline/Frame
4. Width
5. Style
6. Caps
7. Label Length
8. Cursor key : Right (Use with Shift key to go to end of the text.)
9. OK key
10. Escape key
11. Cursor key : Left (Use with Shift key to go to top of the text.)
12. Power key
13. Menu key
14. Font key
15. Character key
16. Tab key
17. Caps key
18. Shift key
19. File key
20. Print key
21. Preview key
22. Frame key
23. Symbol key
24. Deco Mode key
25. Backspace key
26. Enter key
27. Accent key
28. Space key

- Pressing the Preview key (21) displays a preview of the label, and may differ from the actual label when printed.
- Label length shown on the LCD may differ slightly from the actual length when printed.

Specifications

Table with 2 columns: Specification (Dimensions, Weight, Power supply, Tape cassette) and Value.

*1 Visit us at support.brother.com for the latest information about the recommended batteries.

For FAQs, Troubleshooting, and manuals, visit: support.brother.com.

Initial Settings

- 1 Turn your label maker on. Supply power by using six AAA batteries or the optional AC Adapter and then press [Power].
2 Set the language. The default setting is [English].
3 Set the unit of measurement. The default setting is [inch].

NOTE

- The label maker automatically turns off if no keys are pressed within five minutes.
- To cancel any operation, press [Esc].
- After pressing [OK], [Accepted] appears for approximately one second.

DON'T FORGET TO REGISTER! Registering your product will provide purchase confirmation, proof of ownership and, if you choose, allow us to notify you of product enhancements and special offers! You can register online at: www.registermybrother.com
LIMITED WARRANTY Product warranty information can be found online at www.brother-usa.com/brother-support

Accessories

- Tape Cassettes: See the included Supplies and Accessories Guide.
AC Adapter: AD-24ESA/AD-24ESA/AD-24ESAW/AD-24ESA-01/AD-24ESAW-01
Cutter Unit: TC-4 (replacement)
Over time, the Cutter Blade may become blunt from repetitive use. If the Cutter does not cut tape cleanly, replace the Cutter Unit. Contact your local authorized Brother reseller and order item TC-4, the Cutter Unit.

Replacing the Cutter Unit

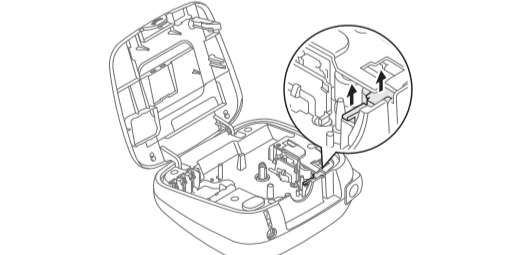

WARNING

Do not touch the cutter blade directly with your fingers.

Printing Labels (cont)

Setting Margins

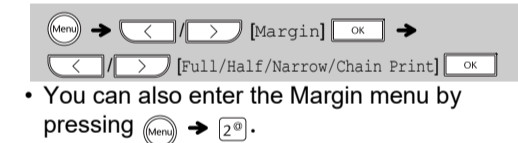

[Full] / [Half] / [Narrow]

Use one of these options to customize margin length before and after your text. The printed dots (·) indicate the end of the label. Cut along the printed dots (·) with scissors.

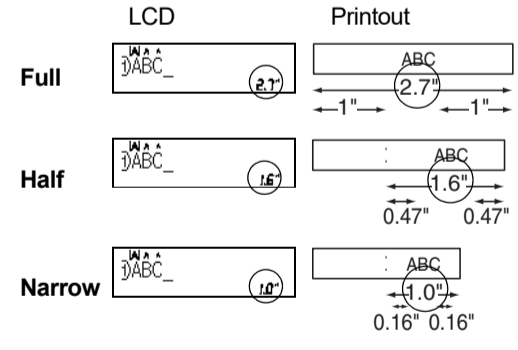

NOTE

- To print more than 1 copy of a label with minimum margin, set the margin to [Narrow].
[Chain Print] (tape-saving option) Use this option to print multiple different labels with narrow margins. This option saves tape.
1. Enter your text.
2. Press [Print]. [Copies:] appears on the LCD.
3. Press the number keys to enter the number of copies you want of this text.
4. Press [OK] to start printing.
5. When [OK to Feed?] appears on the LCD, press [Esc] to change the text.
6. Clear the text, enter the text you want on the next label, and then press [Print].
7. After your last label prints, when [OK to Feed?] appears on the LCD, press [OK].

NOTE

- When you use [Chain Print], feed the tape before using the cutter ([Shift] + [Cut]), otherwise part of the text may be cut off.
- Do not pull the tape, as this may damage the Tape Cassette.

Entering Accented Characters

- Refer to the Accented Characters table in this guide.
- The order of accented characters varies based on the language you selected.

Changing Label Length

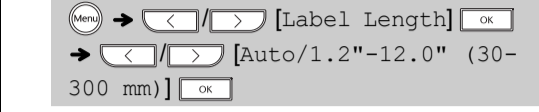

NOTE

- After printing a label, cut along the printed dots (·) with scissors so the label length matches what is shown on the LCD.
- The lock symbol (🔒) appears when you set a specific label length.
- To return to the default length (automatic, based on text length), press [Space], and [Auto] appears on the LCD.

Clearing Text and Settings

To delete individual letters and spaces, press [Clear].

To delete all text:
[Shift] + [Clear] → [Text Only]

To delete all text and settings :
[Shift] + [Clear] → [Text&Format]

Cursor Keys

To move to the end of your text:
[Right] + [Shift]

To move to the beginning of your text:
[Left] + [Shift]

Deco Mode

Use Deco Mode templates to add visual texture to your labels. Refer to the Deco Mode Formats table in this guide.

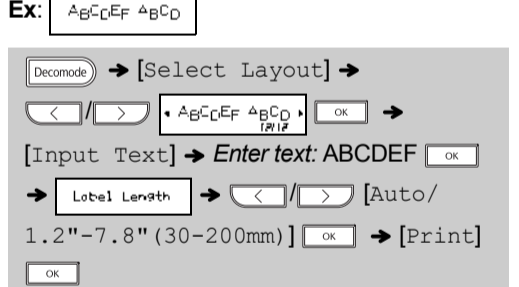

- To exit a template and return to the text entry screen, do one of the following:
a) Press [Esc].
b) Press [Left] or [Right] to select [Cancel], and then press [OK] when "Print" appears on the LCD.

- Templates can be used ONLY with 0.47"(12mm) tape cassettes.
- Maximum label length is 7.8" (200mm) when using templates.
- When [Auto] is selected for [Label Length], the label will automatically adjust to the correct length and print the text one time.
- Press [Space] to return to the [Auto] setting for [Label Length].

