

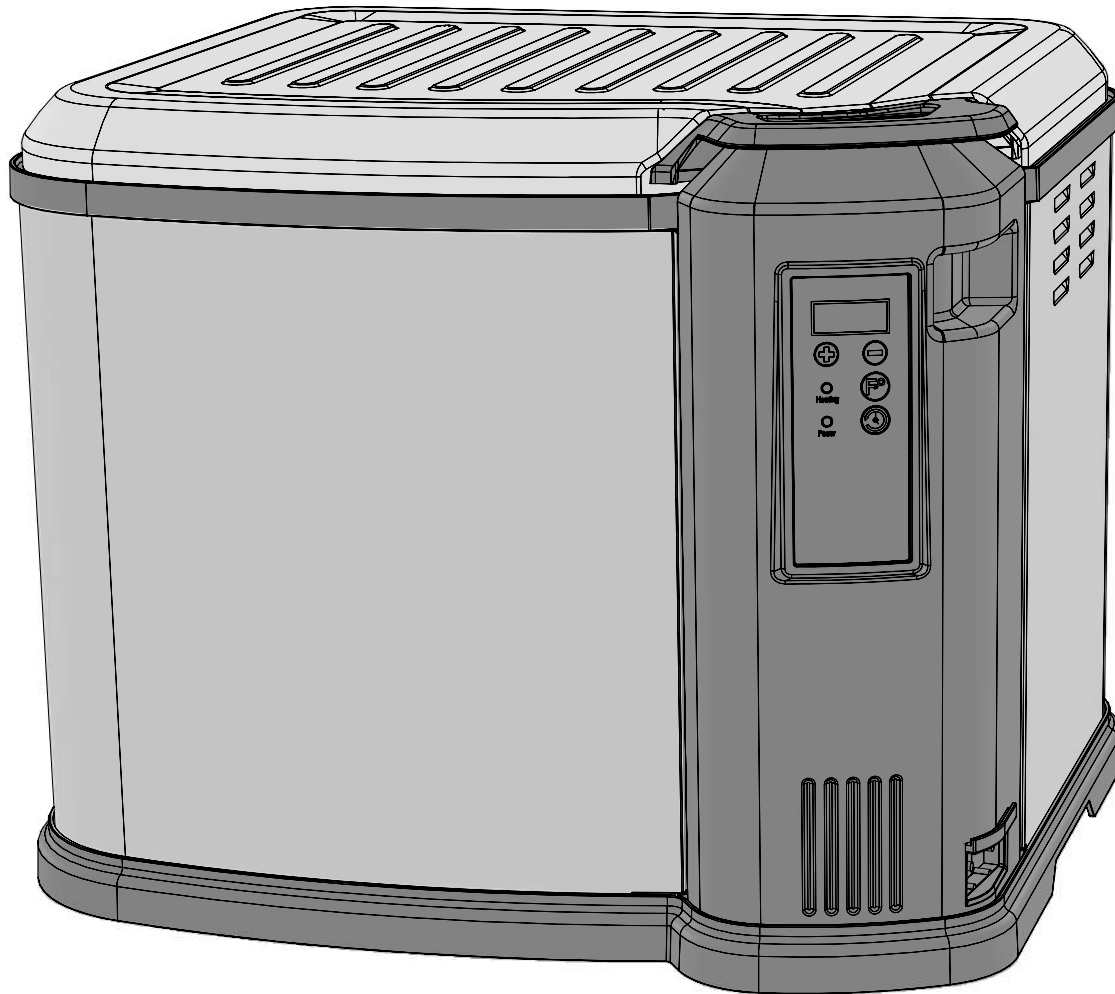

# ELECTRIC TURKEY FRYER

## OPERATION MANUAL & SAFETY INSTRUCTIONS



MANUAL CODE: 9801160007 161108-GB



CSA CERTIFIED TO UL STANDARD 197

*Protected under U.S. Patents and International Patents and Patent Pending  
6,711,992; 6,941,857; 7,412,922; 7,981,459; D625,545; D644,475*



# WARNINGS~IMPORTANT SAFEGUARDS



## READ ALL INSTRUCTIONS

When using electrical appliances, basic safety precautions should always be followed, including but not limited to the following:

- Maximum turkey size is 22 lbs (9.98 kgs.).
- A short cord is provided to prevent possibility of entanglement or tripping that may occur with use of a longer cord.
- Never move appliance when oil or water is above 100 °F(37 °C).
- Do NOT touch hot surfaces. Use lifting hook handle.
- To protect against electric shock, do NOT immerse cord, plugs, or any part of control panel in water or other liquids.
- Do NOT move appliance while in use or HOT.
- This is an ATTENDED appliance. Do NOT leave this appliance unattended during use. Heated liquid inside cooking pot remains dangerously HOT for a period of time after use.
- Unplug from outlet when not in use and before cleaning. Allow to cool before removing parts for cleaning and storing.
- Do NOT operate appliance with a damaged cord, plug, or after appliance malfunctions, or has been damaged in any manner. Contact Masterbuilt Customer Service for assistance 1-800-215-7204.
- Accessory attachments not supplied by Masterbuilt Manufacturing, Inc. are not recommended and may cause injury.
- Do NOT use outdoors, appliance is for indoor use only.
- Do NOT let cord hang over edge of table or counter, or touch hot surfaces.
- Do NOT place on or near a HOT gas or electric burner, or in a heated oven.
- ALWAYS attach breakaway cord w/plug to appliance first, then plug cord in outlet.
- To disconnect, dial down temperature button (F°) to OFF setting, then remove plug from outlet.
- Do NOT use appliance for other than intended use.
- If oil begins to smoke, IMMEDIATELY turn appliance off.
- NEVER overfill cooking pot. Do NOT exceed max fill line.
- Open lid with caution to prevent being burned by escaping steam.
- Add food slowly to avoid boil over.

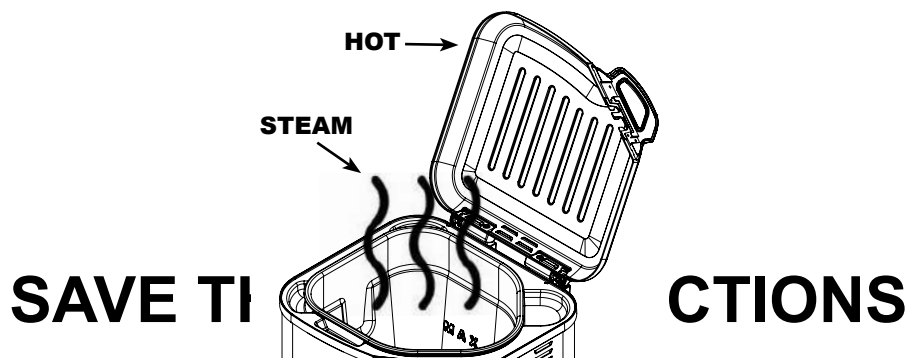

### IMPORTANT INFORMATION: DO NOT USE AN EXTENSION CORD.

- Use of extension cord increases risk of entanglement or tripping.
- Use of extension cord causes loss of energy and appliance may not heat properly.
- Do NOT operate appliance with a damaged cord, plug, or after appliance malfunctions, or has been damaged in any manner. Contact Masterbuilt Customer Service for assistance at 1-800-215-7204.



**DO NOT RETURN TO RETAILER** For Assembly Assistance, Missing or Damaged Parts  
 Call: MASTERBUILT Customer Service at 1-800-215-7204.  
 Please have Model Number and Serial Number available when calling.  
 These numbers are located on silver label on back of unit.

## PARTS LIST

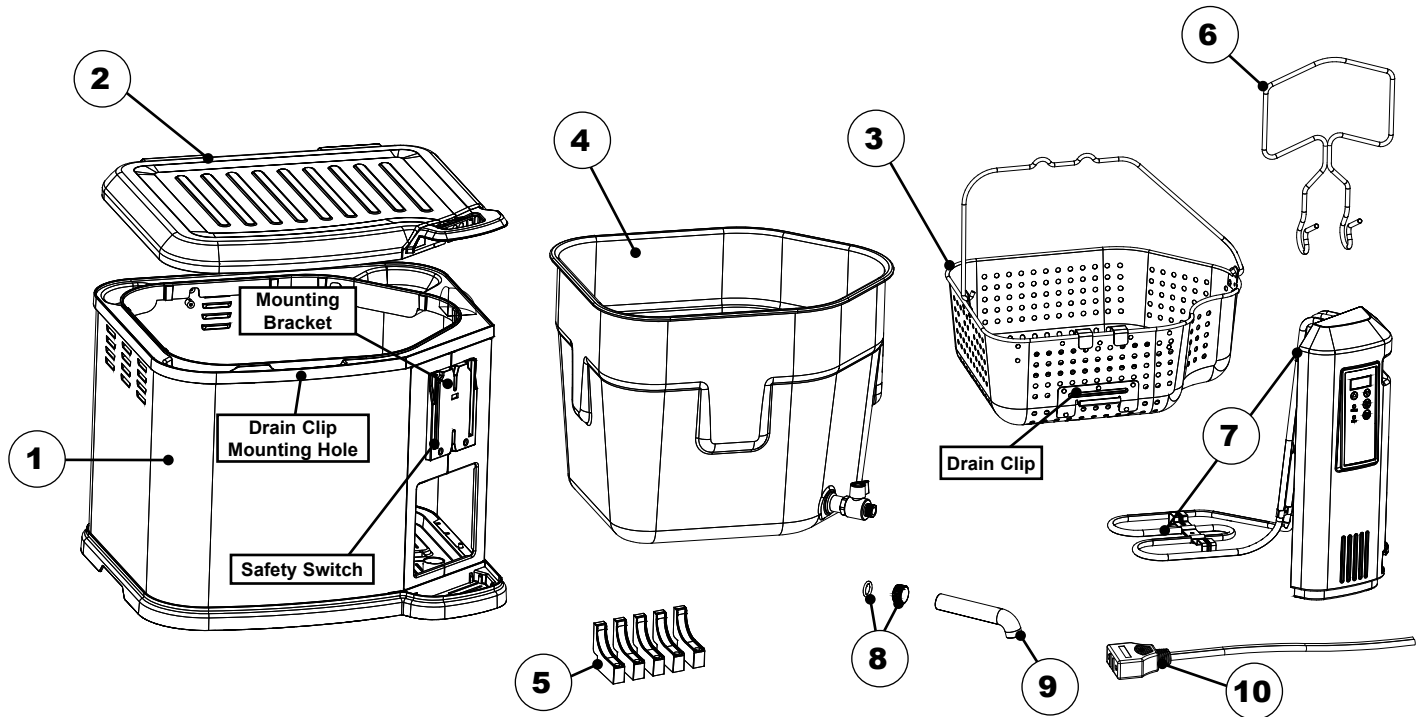

PART NO.	QTY	DESCRIPTION	PART NO.	QTY	DESCRIPTION
1	1	Outer Shell	6	1	Double Lifting Hook
2	1	Lid	7	1	Control Panel w/ Element
3	1	Turkey Basket	8	1	Safety Cap & Seal
4	1	Inner Pot w/ Valve	9	1	Valve Spout
5	5	Inner Pot Supports	10	1	Break-away Cord

## REPLACEMENT PARTS LIST

PART NO.	REPLACEMENT PART	ITEM NO.	PART NO.	REPLACEMENT PART	ITEM NO.
1	Platinum Outer Shell (23013115)	9901160001		Lid Handle Kit	9901130004
2	Lid Kit	9901130006		Rubber Foot Kit	9901130005
3	Turkey Basket	9001100012		Instruction Manual	9801160007
4	Inner Pot w/ Valve	9901130008		Cook booklet	9801160027
5	Inner Pot Support Kit	9901090018		Fryer Basket Divider Kit	9901160003
6	Double Lifting Hook	9001090020		Blue Outer Shell (23013215)	9901160004
7	Control Panel w/ Element	9001160005		Red Outer Shell (23013315)	9901160005
8	Safety Cap & Seal Kit	9901100001		Onyx Outer Shell (23013415)	9901160006
9	Valve Spout Kit	9901090009		Copper Outer Shell (23013515)	9901160007
10	Break-away Cord	9001150010			

# ASSEMBLY INSTRUCTIONS

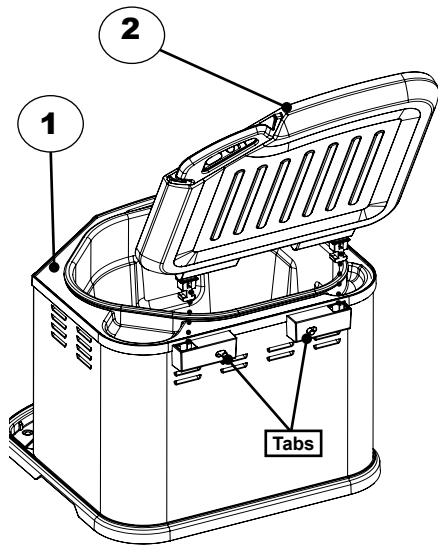

## Step 1

Insert hinge on lid (2) into outer shell (1). Lid will snap into place when assembled correctly.

**Note:** To remove lid push tabs together on outer shell, and pull lid up.

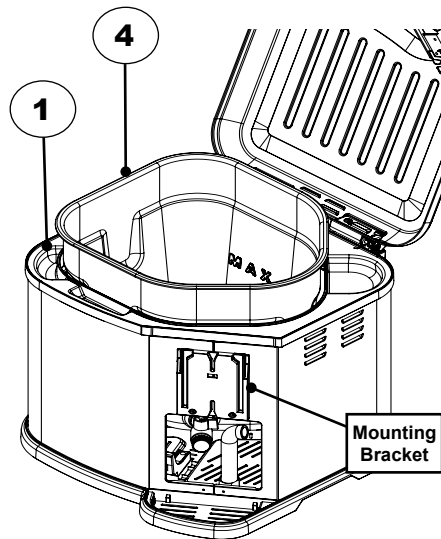

## Step 2

Insert inner pot (4) into outer shell (1). Insert inner pot at an angle to fit valve into side opening of outer shell.

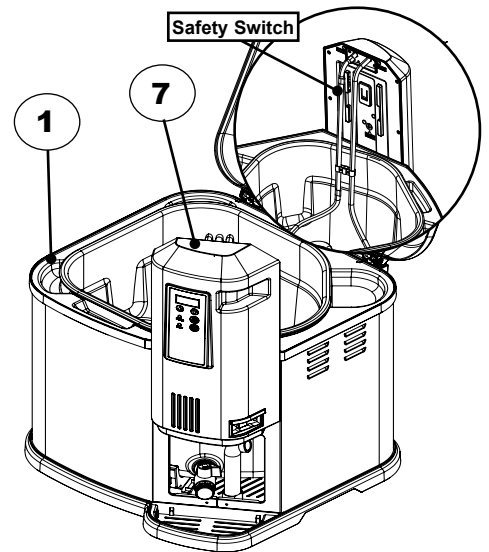

## Step 3

Slide control panel and element (7) down onto mounting bracket (shown in Step 2) on side of outer shell (1).

**Note:** The control panel is correctly attached when the heating element is positioned inside the inner pot. Control panel must be correctly attached for appliance to operate.

A built in safety switch on control panel will prevent element from heating if not mounted properly.

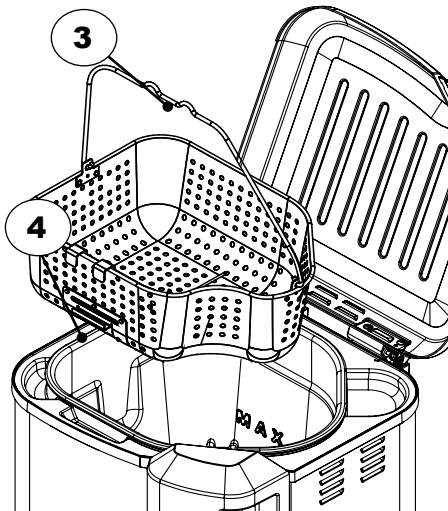

## Step 4

Place basket (3) inside inner pot (4).

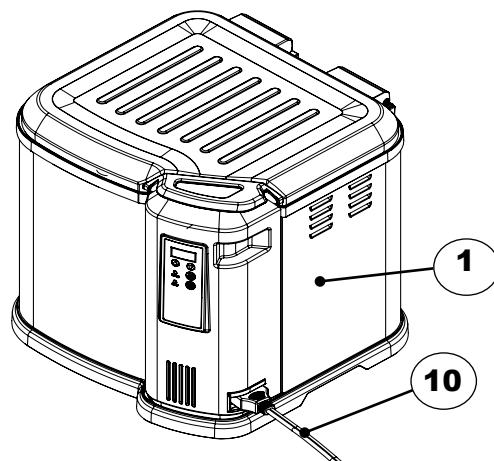

## Step 5

Insert breakaway cord (10) into connection on outer shell (1). Make sure "This Side Up" is shown on top for proper connection.



**WARNING**



### CALIFORNIA PROPOSITION 65

This product contains chemicals known to the State of California to cause cancer, birth defects or other reproductive harm.

# OPERATING INSTRUCTIONS

## Step 1

Mount control panel and element onto bracket on outer shell (see Step 3 on pg. 3).

**Note: The control panel is correctly attached when the heating element is positioned inside the inner pot and fully submerged in cooking oil or water during use.**

## Step 2

Add oil or water to the MIN 1.5 gallons (6qts) or MAX 2.75 gallons (11qts) fill line (see pg. 7). **Note:** Unit uses approximately 2.75 gallons (11qts) of oil when frying a turkey. Always fill oil to bottom of MAX fill line.

## Step 3

Attach power cord to control panel (see Step 5 on pg. 3). Plug power cord into an outlet (refer to "Warnings & Important Safeguards" section of manual). Power light will illuminate indicating the unit is plugged in and element is mounted correctly to the mounting bracket.

## Step 4

Press dial to set temperature. Ready light will illuminate when unit has reached set temperature and is ready for use.

## Step 5

Push timer button to set to desired time. Once time has been set, release button and the timer will start. Timer counts down by minutes only until less than 1 minute remaining. Numbers will flash while counting down. Timer will beep when time has expired. To reset timer to 0 press and hold timer button while numbers are flashing. Release and press again to reset.

## STARTER TIPS

**FOR BEST RESULTS, READ** the following start up tips before using this product. Remember this is an ELECTRIC unit and has different characteristics than a gas unit.

**Note:** Watch "Getting to know your XL Butterball Indoor Electric Turkey Fryer" on [www.masterbuilt.com](http://www.masterbuilt.com).

**FOR SAFETY,** heating element only heats up when properly attached to mounting bracket (see previous page for instructions). This is a powerful heating element and may cause circuit breaker to trip. Minimize occurrences by operating any additional appliances on separate circuit. Tripping circuit breaker will NOT damage unit or household electrical system.

**PRE-HEATING** oil or water may take up to 45 minutes. Take advantage of this time to prepare foods for cooking. For optimum performance, completely pre-heat unit to cooking temperature before frying or boiling foods. Keep lid CLOSED during pre-heating and cooking. This will reduce heating time and keep temperature more consistent.

**POWER LIGHT (orange)** will illuminate indicating power cord is plugged into outlet.

**READY INDICATOR LIGHT (green)** will turn ON when set temperature is reached. Indicator light will turn on and off to maintain set temperature.



## CAUTION

- Do not use appliance without water or oil in pot. Unit can be severely damaged if heated while empty.
- Place unit on level and stable surface to prevent tipping.
- Hot when in use.
- Do not overfill pot past max fill line.
- Do not mix different types of oil at the same time.
- Never melt fat or lard on the heating element or in basket.
- Risk of fire and electric shock. Replace only with manufacturer's cord set, part number 9001150010



# TURKEY PREPARATION

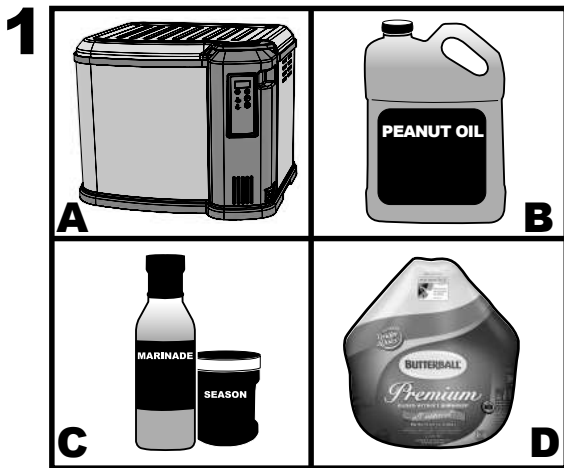

- A. Butterball® Indoor Electric Turkey Fryer  
B. 2.75 gallons (11 qts.) of oil. Peanut oil is recommended because of the great taste and higher smoke point but any common cooking oil may be used.  
C. Your favorite marinade and season  
D. Butterball® 18-20 lb. (8.16-9.07 kgs.) turkey

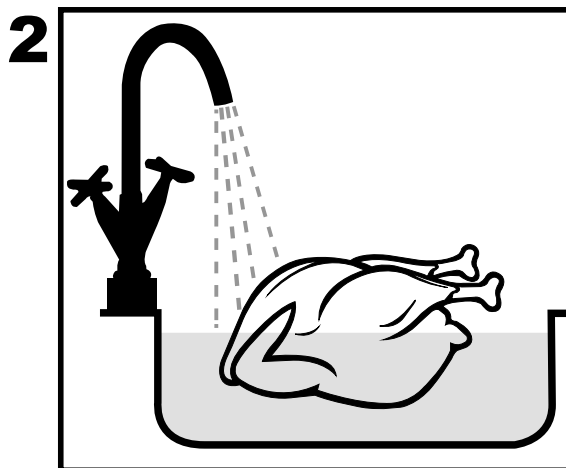

Rinse turkey thoroughly with warm water or soak in a warm water bath for no more than 30 minutes to ensure cavities are free of ice.

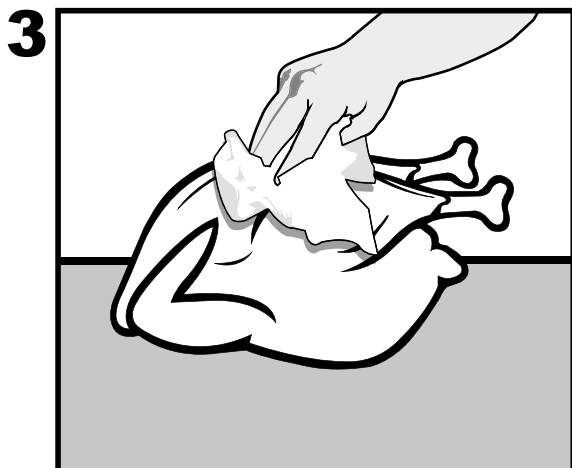

Pat turkey completely dry on outside with paper towels.

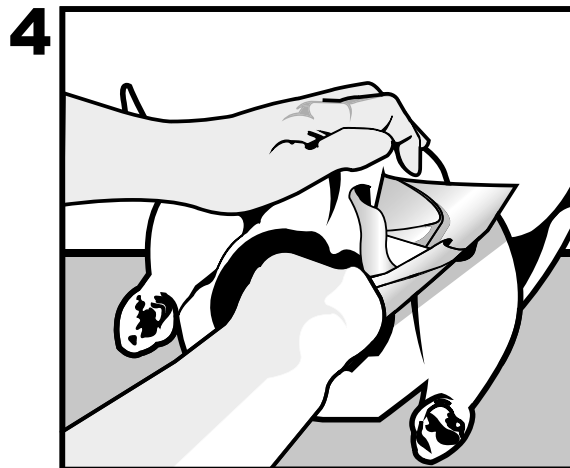

Dry inside cavities using paper towel as shown.

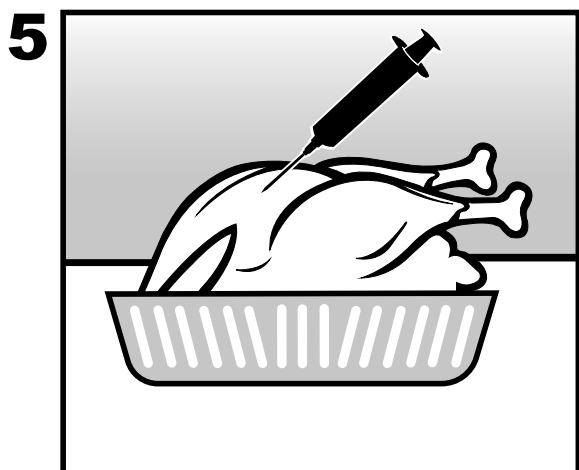

If desired inject turkey with marinade (not included). Insert 4 to 8 oz. into each side of turkey breast, thigh, leg, and wing for a total of 8 to 16 oz.

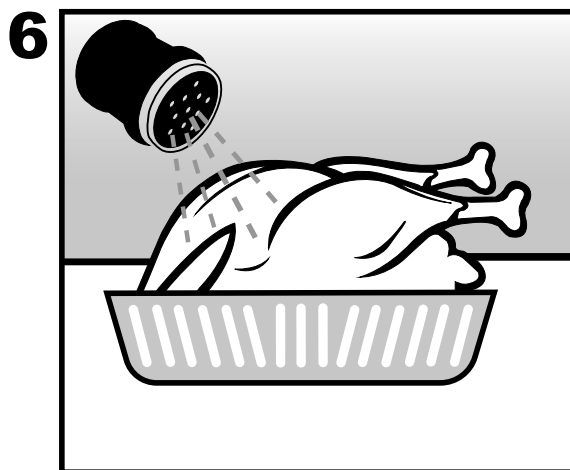

Season inside and outside of turkey with your favorite seasoning (not included).

# HOW TO FRY A TURKEY IN THE BUTTERBALL® ELECTRIC TURKEY FRYER

## DEEP FRIED WHOLE TURKEY

A 18-20 lb. (8.16-9.07 kgs.) turkey is recommended. However, you can deep fry up to a **22 lb (9.98 kgs.)** turkey in this unit. **DO NOT EXCEED 22 lbs. (9.98 kgs.)**.

Frozen turkeys that are to be used for deep frying should be thoroughly defrosted 35 ° - 40 ° F (1.6° - 4.4 °C). The turkey must be rinsed on the outside and in the cavities with warm water or soaked in a warm water bath for no more than 30 minutes to remove any possibility of remaining ice crystals and then dried thoroughly with paper towels before immersing in hot oil. This will reduce splatter.

### THAWING TURKEY

Allow approximately 24 hours for every 4 lbs. (1.8 kgs.) of turkey thawed in the refrigerator.

### COOKING INSTRUCTIONS

1. Ensure that the turkey is completely thawed and free of ice and water. Remove neck and giblet bag. Pay special attention to inner cavity area when checking for ice or water.
2. Make sure drain valve is closed. Fill pot with oil to the bottom of max fill line.
3. Set control dial to 375 °F (191 °C) (pre-heating time may take up to 45 minutes).
4. Close lid on the fryer.

5. While oil is pre-heating, prepare the turkey (see pg. 5). Inject with your favorite marinade and season the outside of the turkey with your favorite seasoning .

### 6. CALCULATE COOKING TIME

The formula for calculating turkey cooking time is to fry turkey 3.5-4 minutes per pound (0.45 kg.). Using a meat thermometer check turkey breast to ensure it has reached the appropriate cooking temperature 165 °F-170 °F (74 °C-77 °C). If you do not have a meat thermometer then fry turkey 4 minutes per pound (0.45 kg.).

7. Ready indicator light (green) will illuminate when temperature is reached.
8. Place turkey horizontally in basket, breast side up (Fig. A).
9. Wearing protective gloves or mitts, hook the basket handle with the lifting hook and **VERY SLOWLY** lower the basket into the hot oil (Fig. B).
10. With basket in place, close lid.
11. Set digital timer to calculated time (see Operating Instructions pg. 4).
12. Be certain to cook for complete calculated time .
13. When time is up, turn the turkey fryer to OFF and unplug from outlet. Lift the basket from the hot oil slowly, hooking the drain clip on basket into drain clip mounting hole (Fig. C).
14. Allow turkey to rest in basket for 10 minutes before removing for carving and serving. The turkey can remain in the basket to cool until ready to serve.

- NOTE:**
- Cooking conditions vary. Insert a food thermometer 2 inches (5.08 cm.) into the deepest part of turkey breast and make sure an internal temperature of 165 °F (74 °C) is reached.
  - Purchase 2.75 gallons (11 qts.) of oil to be used, although unit uses slightly less than 3 gallons (12 qts.).
  - Butterball turkey is recommended however if you have another brand please remove the pop-up cooking indicator and leg ties.

Fig. A

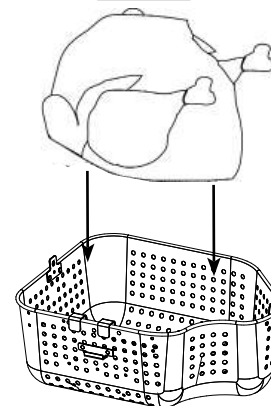

Fig. B

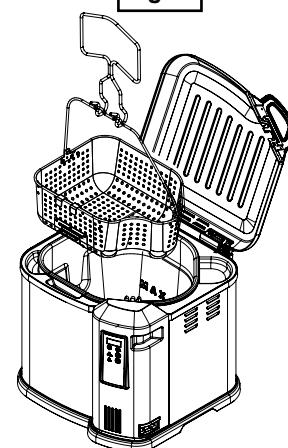
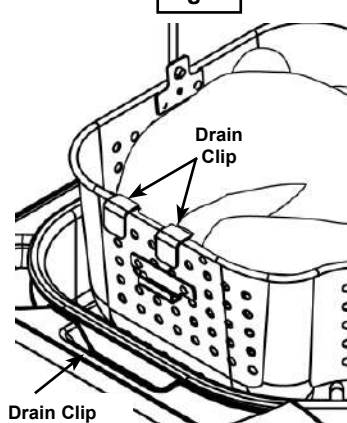

Fig. C



### DEEP FRIED TURKEY BREAST

Follow the above directions and safety precautions and adjust formula to 7 minutes per pound (0.45 kg.). Start at 375 °F (191 °C) after lowering turkey breast into unit reduce temperature to 325 °F (163 °C) for entire cooking time.

$$\begin{array}{r} 6 \text{ lbs} \\ \times 7 \text{ min} \\ \hline 42 \text{ min Total Cooking Time} \end{array}$$

- NOTE:**
- Reducing temperature to 325 °F (163 °C) is for cooking a turkey breast ONLY. Do not reduce the temperature when cooking a whole turkey.

## HOW TO STEAM USING APPLIANCE

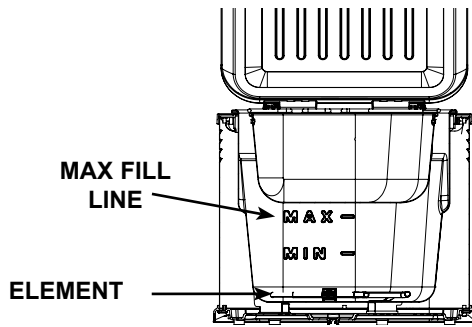

- Add water to Max Fill Line. Do not add water past this line. Do not allow water to completely evaporate. This will cause element to overheat and damage the unit. Make sure basket is in place, as shown on left, to steam.
- Water will boil at 212 °F (100 °C). When steaming or boiling turn dial to 375 °F (191 °C) to ensure unit will not cycle and water will continue boiling.

## DRAIN VALVE

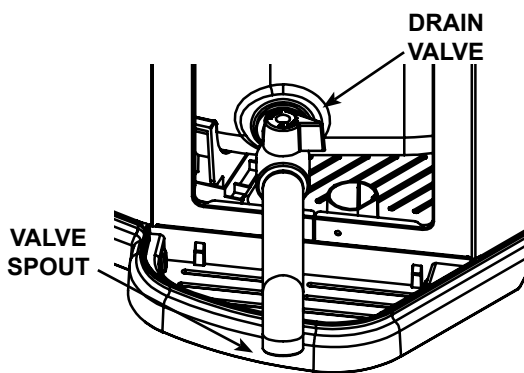

- Valve must be in OFF position.
- Remove safety cap on drain valve.
- Screw valve spout attachment onto drain valve. Do not overtighten. This could damage threads and cause leakage. If spout becomes snug in the up position turn counterclockwise until it is in the down position.
- Align spout over container with opening facing downward. Open valve to drain.
- Close valve when complete.
- Do NOT store water in appliance.

## CAVITIES

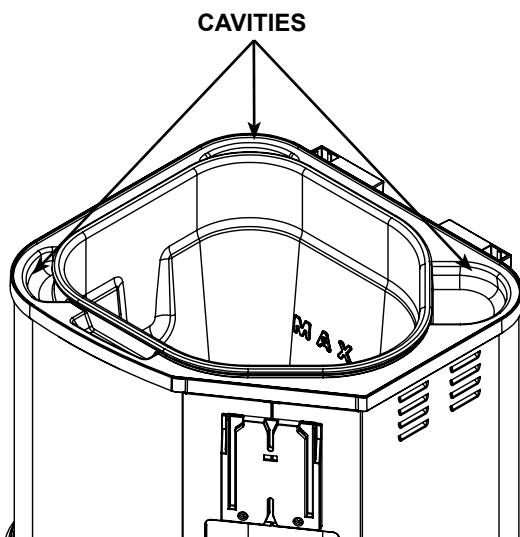

- Cavities in unit are designed to catch grease and condensation from steam. Wipe out cavities using damp cloth after each use.
- When steaming, cavities may become full before finished cooking, drain with sponge or other absorbent material. Caution! Water will be hot.



## HOW TO CLEAN UNIT

### ⚠ WARNING ⚠

- Do not place control panel under running water. Immersing control panel and cord can cause electrocution.

Masterbuilt recommends cleaning unit prior to use.

Clean lid, inner pot, valve spout, lifting hook and basket with a damp cloth or sponge using a mild detergent. Rinse and dry thoroughly.

Clean outer shell, cord, control panel and element with a damp cloth or sponge using a mild detergent. Dry thoroughly. NEVER put these parts in a dishwasher or submerge in water.

## STORAGE & MAINTENANCE

### ⚠ CAUTION ⚠

- Disconnect electric cord from outlet, before cleaning, servicing and/or removing heating element. Electrical shock can result in personal injury or death.
- Do not pour used oil in sink. Drain it back into oil containers.

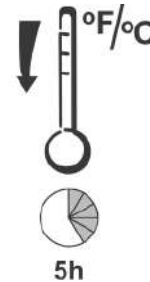

Turn appliance off, unplug and let cool for 2 hours if using water, 5 hours if using oil before cleaning or storing.

## TROUBLESHOOTING GUIDE

SYMPTOM	CAUSE	POSSIBLE SOLUTION
Power light won't come on.  If none of these solutions work, contact Masterbuilt at 1-800-215-7204.	Unit not plugged into wall.	Check wall connection.
	Break-away cord is loose or not connected.	Disconnect and reconnect power cord sections.
	Control Panel is not attached to outer shell correctly.	Remove and reinstall. Make sure control panel is mounted onto the outer shell bracket to engage safety switch.
	Household circuit breaker tripped.	Make sure other appliances are not operating on the same electrical circuit. Check household breakers.
Power light is on, unit isn't heating.	Temperature has not been set.	Unit will not begin heating until temperature is set.
	Temperature setpoint already reached.	Allow unit to cool below setpoint or enter higher setpoint.
Unit takes excessive amount of time to heat up (longer than 1 hr 15 mins).	Lid not in place.	Close lid on unit to retain heat.
Unit is not operating, POWER indicator flickers, and digital display reads E1.	Temperature sensor is malfunctioning.	Contact Masterbuilt at 1-800-215-7204.
Unit is not operating, POWER indicator flickers, and digital displays reads E2.	Temperature sensor is malfunctioning.	Contact Masterbuilt at 1-800-215-7204.
In BOIL mode unit ceases to function and digital display reads E3.	Unit is detecting water temperature more than 250°F	Appliance will exit from E3 mode once water temperature cools to 200°F.
Unit displays code EH and stops working or is not working at all.	No oil or water in pot.	Unplug unit from power source, fill inner pot with oil or water. Plug unit back in.

**If symptom is not listed here OR in FAQ section, please contact Masterbuilt at 1-800-215-7204.**

## FREQUENTLY ASKED QUESTIONS

### Why won't my turkey fryer turn on?

The Control Panel features a "Safety Switch" that must be mounted properly on the mounting bracket of the outer shell for unit to power on (see pg.3). Power light will illuminate when control panel is mounted correctly.

### How much oil do I need to use?

Fryer will require approximately 2.75 gallons (11qts) of oil max. The MAX fill line is the maximum amount of liquid that can safely be used in this unit. Filling to the line is more than enough water or oil to prepare most food in this (see pg. 7).

### What type of oil should I use?

Peanut oil is recommended because of the great taste and higher smoke point but any common cooking oil may be used.

### How hot will the oil become?

Oil will reach 375 °F (191 °C) in approximately 45 minutes. Oil temperature will decrease when turkey is placed in fryer. Follow set cooking time in this manual.

### Should I keep the lid on during use?

Yes, the lid helps retain heat, and keeps splatter inside unit.

### What size turkey can I deep fry in this unit?

A 18-20 lb. (8.16-9.07 kgs.) turkey is recommended. However, you can deep fry up to a 22 lb. (9.97 kgs.) turkey in this unit. **DO NOT EXCEED 22 lbs. (9.97 kgs.).**

### Can an extension cord be used with this unit?

No, extension cords will lose electric current resulting in increased cooking time and decreased performance. Extension cords can also pose a trip hazard.

### Does the turkey go in the basket breast side up or down?

Turkey should be placed horizontal in basket, breast side up (see Fig. A on pg. 6).

### I followed the formula and the turkey did not fully cook. What went wrong?

Cooking conditions may vary. Turkey could have been cold. Bring turkey to room temperature before frying. Sometimes a cold or frozen spot in a joint or deep in the turkey breast does not allow that section to cook properly. For best results wash with lukewarm water and pat dry inside and outside with paper towels before injecting with marinade.

**VISIT OUR WEBSITE FOR MORE INFORMATION AND GREAT TASTING RECIPES.**

**[www.masterbuilt.com](http://www.masterbuilt.com)**



**DO NOT RETURN TO RETAILER** For Assembly Assistance, Missing or Damaged Parts

Call: MASTERBUILT Customer Service at 1-800-215-7204.

Please have Model Number and Serial Number available when calling.

These numbers are located on silver label on back of unit.

# PROGRAMMED COOKING: SETUP AND USAGE

To power up, plug unit into power source. Initially the power indicator will illuminate red and the digital readout will blink 375° F, indicating the unit is in standby mode.

## Temperature Mode Select

### Step 1

Select desired cooking mode by pressing the temperature button (F°) and push +/- buttons to scroll through mode options of OFF/BOIL/300 °F/325 °F /350 °F or 375 °F.

### Step 2

Press temperature button (F°) again to set mode.

**\*Note:** The mode function can be changed at any time by pressing the temperature button.

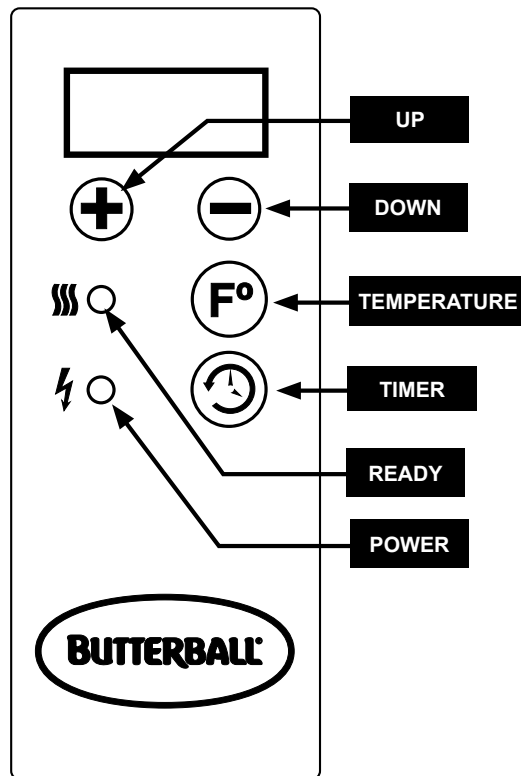

## Temperature Mode Functions

**OFF:** The display will blink OFF 5 times, after which time the unit will power down. Please allow adequate time for liquids to cool as the temperature will not immediately drop once the unit has powered down.

**BOIL:** (Use only water in boil mode) In this mode, the indicator will read BOIL. Slowly lower food once water comes to a boil. The ready light will not illuminate during boil operation.

**\*Note:** Water will not instantaneously begin to boil and must still have time to reach desired temperature.

**300 °F/325 °F/350 °F/375 °F:** Once desired frying temperature is indicated, simply press temperature button to select cooking temp. In fry mode the letter "H" will blink during pre-heat while the element cycles on and will cease to blink once temp has been reached. There is no pre-heat "H" indicator when boiling. The green ready indicator will illuminate when oil reaches the set temp.

**\*Note:** Oil will not instantaneously reach desired temperature. Please allow time for pre-heat.

## Timer Programming

### Step 1

Program the timer by pressing the (⌚) timer button. Timer will flash. Select time from 00 – 99 minutes by pressing the +/- buttons in 1 minute increments, or hold down the +/- button to change time in 10 minute increments.

**\*Note:** If no time is selected within 5 seconds, the timer will set to the previous programmed time

### Step 2

Once the desired time is indicated on the digital screen, press the time button again to set. The timer will stop flashing indicating the time has been set. The timer can be changed during any portion of the cooking process by simply pressing time button and repeating steps 1 and 2 to set.

The timer will sound out 10 long beeps when time is up.

**\*Note:** Cooking times and temperatures may vary due to altitudes.

**NOTE:** In the event that the cord becomes disconnected during cooking, the fryer will maintain the last set time and temperature for up to 2 minutes. However, some heat loss could occur during the time that the fryer is disconnected from power source.

## ONION STRAW BLOSSOM

Oil for frying  
 1/2 cup sour cream  
 1/4 cup chunky salsa  
 2 large (12 oz. each) white or Vidalia onions  
 3/4 cup all-purpose flour  
 2 tbsp. Mexican chili powder  
 1 tbsp. garlic salt  
 1 tsp. black pepper  
 1 cup all-purpose flour  
 1/4 cup cornstarch  
 1 tsp salt  
 1 (12 oz.) non-alcoholic beer

Preheat oil to 375 °F (191°C) in electric fryer. For sauce, combine sour cream and salsa in a small bowl. Refrigerate until serving. To make onion flower, peel onions and cut 3/4 inch off the top of each onion. Trim, but do not cut off root end. Cut each onion into quarters from the top to 1/2 inch from root end. Then cut each quarter section into 4 thin wedges, cutting to within 1/2 inch from root end. Using a sharp knife, remove some of the center petals, careful not to cut through the bottom. Discard center petals. Carefully spread the remaining petals apart. Place the 3/4 cup flour, chili powder, garlic salt, and pepper in a large heavy-duty plastic bag; add onion, shaking to coat. Shake off excess flour mixture. Repeat with remaining onion. Whisk the 1 cup flour, cornstarch, salt, and beer in a medium bowl until smooth. Dip onions in beer mixture, moving so onions are thoroughly coated. Drain to remove excess coating. Using a long-handled slotted spoon or wire basket, lower one onion, root-end side down, into hot oil. Fry about 3 to 4 minutes or until golden brown and onion is tender. Drain on wire rack. Spoon sauce into center of onion; serve immediately.

## CITRUS SEAFOOD COCKTAIL

12 oz. bay scallops (fresh or thawed)  
 12 oz. fresh or frozen large shrimp with shells  
 1 tsp finely shredded ruby red grapefruit peel  
 1/3 cup ruby red grapefruit juice  
 1/4 cup salad oil  
 2 tbsp thinly sliced green onion  
 2 tbsp finely chopped red or yellow sweet pepper  
 1 tbsp white balsamic vinegar or white wine vinegar  
 1 tbsp honey  
 1 1/2 tsp. anise seeds, crushed  
 1/2 tsp. ground cinnamon  
 1/2 of a fresh pineapple, peeled, cored, and coarsely chopped  
 2 ruby red grapefruit, peeled and sectioned  
 2 oranges peeled and sectioned

Preheat fryer to 250 °F (121 °C) for boiling. Peel and devein shrimp, leaving tails intact. Cook scallops for 1-3 minutes or until they turn opaque. Cook shrimp for 1-3 minutes or until they turn pink. Do not combine yet. Drain, and rinse under cold water. Drain well. Place shrimp and scallops in a plastic bag set into a deep bowl. For marinade, combine grapefruit peel, grapefruit juice, salad oil, green onion, sweet pepper, vinegar, honey, anise seeds, cinnamon, and 1/2 tsp. salt. Pour over seafood and seal bag. Refrigerate for 2-24 hours, turning bag occasionally. To serve, drain seafood mixture, discarding marinade. Gently combine seafood, pineapple, grapefruit sections, and orange sections. Serve in cocktail cups or glasses.

## FRIED CATFISH

4 lbs. fresh or frozen catfish fillets, thinly sliced  
 1/2 cup prepared mustard  
 Oil for frying  
 1 1/2 cups cornmeal  
 3 tbsp. of your favorite cajun seasoning

Thaw fish, if frozen. Rinse fish; pat dry with paper towels. Cut fish into 2-inch pieces. Combine fish and mustard; chill 15 minutes.  
 Preheat oil to 375 ° F (191 °C). Combine cornmeal and favorite cajun seasoning; stir well with a whisk. Evenly coat all sides of catfish with cornmeal mixture. Fry 6 or 8 pieces at a time for 4 to 5 minutes or until golden.  
 Remove from hot oil and drain on paper towels.

## HOT WINGS

2 gallons oil for frying  
 2 lbs. chicken wings  
 1/2 cup butter  
 10 tbsp your favorite hot sauce

Preheat oil to 375 °F (191°C).  
 Wash wings, split at each joint, and discard tips.  
 Deep fry for 10-15 minutes until crispy. Drain well.  
 Melt butter and combine with hot sauce.  
 Dip wings in hot sauce.

**For more recipes and cooking tips visit us online at  
[www.masterbuilt.com](http://www.masterbuilt.com)**

**TO ENSURE THAT IT IS SAFE TO EAT, FOOD MUST BE COOKED TO THE MINIMUM INTERNAL TEMPERATURES LISTED IN THE TABLE BELOW.**

USDA* Safe Minimum Internal Temperatures	
Fish	145 °F (63 °C)
Pork	160 °F (71 °C)
Egg Dishes	160 °F (71 °C)
Steaks and Roasts of Beef, Veal or Lamb	145 °F (63 °C)
Ground Beef, Veal or Lamb	160 °F (71 °C)
Whole Poultry (Turkey, Chicken, Duck, etc.)	165 °F (74 °C)
Ground or Pieces Poultry (Chicken Breast, etc.)	165 °F (74 °C)

\* United States Department of Agriculture

# COOKING CHART

## Frying Non-Frozen Foods

(Oil may take up to 35 minutes to reach desired temperature)

Food	Maximum Qty.	Temperature	Time
French Fries	2 lbs. (0.91 kgs.)	375 °F (191 °C)	10-12 min.
Fried Chicken	6 pieces	350 °F (177 °C)	14-18 min.
Mushrooms	2 lbs. (0.91 kg.)	325 °F (163 °C)	10-12 min.
Fish Fillets	2 lbs. (0.91 kg.)	375 °F (191 °C)	6-8 min.
Whole Turkey	20 lbs. (9.07 kgs.)	375 °F (191 °C)	3.5-4 min. per lb(0.45kg)
Hot Wings	2 lbs. (0.91 kgs.)	375 °F (191 °C)	10-15 min.

## Frying Frozen Foods

(Refer to instructions on food packaging first)

Fried Okra	1 lb. (.45 kgs.)	375 °F (191 °C)	5-7 min.
Chicken Nuggets	1 lb. (.45 kgs.)	375 °F (191 °C)	7-8 min.
Mushrooms	2 lbs. (0.91 kg.)	375 °F (191 °C)	8-9 min.
Fish Sticks	1 lb. (.45 kgs.)	375 °F (191 °C)	6-7 min.
Corn Dogs	8 lbs. (3.6 kgs.)	375 °F (191 °C)	see packaging
Cheese Sticks	1 lb. (.45 kgs.)	325 °F (163 °C)	see packaging

## Boiling Non-Frozen Foods\*

Corn on the Cob (short ears)	12 cobs	375 °F (191 °C)	5-8 min.
Shrimp	5 lbs. (2.3 kgs.)	375 °F (191 °C)	3-4 min. or until pink
Red Potatoes	3 lbs. (1.36 kgs.)	375 °F (191 °C)	25 min.
Eggs	1 dozen	375 °F (191 °C)	10 min.
Pasta Shells	2 lbs. (0.91 kg.)	375 °F (191 °C)	Until tender
Hot Dogs	25	375 °F (191 °C)	2-3 min.

## Steamed Foods\*

(refer to instructions on food packaging first)

King Crab Legs	5 lbs. (2.3 kgs.)	375 °F (191 °C)	5-8 min.
Clams/Mussels	5 lbs. (2.3 kgs.)	375 °F (191 °C)	5-7 min. or until open
Yellow Squash w/ Red Peppers	2 lbs. (0.91 kg.)	375 °F (191 °C)	steam until tender
Blue Crabs	8	375 °F (191 °C)	6-10 min.
Lobster	1-3	375 °F (191 °C)	10-12 min.

*\*Water will boil at 212 °F (100 °C). When steaming or boiling turn dial to 375 °F (191 °C) to ensure unit will not cycle and water will continue boiling.*

## ⚠ WARNING ⚠

- **NEVER** place frozen or icy poultry in oil. Use extreme caution when cooking frozen foods. Never fill oil past max fill line or exceed maximum amount of food in basket. Spillover can cause serious injury. Slowly lower basket into hot oil and cover with lid. Always wear protective gloves or mitts.
- When using drain hook on basket, make sure that basket is firmly in place on rim of pot before releasing handle so basket will not fall back into hot oil or water causing personal injury.

## LIMITED WARRANTY

Masterbuilt warrants its products to be free from defects in material and workmanship under proper assembly, normal use and recommended care for 90 days from the date of original retail purchase.

Masterbuilt warranty does not cover rust of the unit.

Masterbuilt requires reasonable proof of purchase for warranty claims and suggests that you keep your receipt. Upon the expiration of such warranty, all such liability shall terminate.

Within the stated warranty period, Masterbuilt, at its discretion, shall repair or replace defective components free of charge with owner being responsible for shipping. Should Masterbuilt require return of component(s) in question for inspection Masterbuilt will be responsible for shipping charges to return requested item.

This warranty excludes property damage sustained due to misuse, abuse, accident, damage arising out of transportation, or damage incurred by commercial use of this product.

This expressed warranty is the sole warranty given by Masterbuilt and is in lieu of all other warranties, expressed or implied including implied warranty, merchantability, or fitness for a particular purpose. Neither Masterbuilt nor the retail establishment selling this product, has authority to make any warranties or to promise remedies in addition to or inconsistent with those stated above.

Masterbuilt's maximum liability, in any event, shall not exceed the purchase price of the product paid by the original consumer/ purchaser. Some states do not allow the exclusion or limitation of incidental or consequential damages. In such a case, the above limitations or exclusions may not be applicable.

**California residents only:** Notwithstanding this limitation of warranty, the following specific restrictions apply; if service, repair, or replacement of the product is not commercially practical, the retailer selling the product or Masterbuilt will refund the purchase price paid for the product, less the amount directly attributable to use by the original buyer prior to the discovery of the nonconformity. Owner may take the product to the retail establishment selling this product in order to obtain performance under warranty. This expressed warranty gives you specific legal rights, and you may also have other rights which vary from state to state.



Go online [www.masterbuilt.com](http://www.masterbuilt.com)  
or complete and return to  
Attn: Warranty Registration  
Masterbuilt Mfg., LLC  
1 Masterbuilt Court - Columbus, GA 31907

Name: \_\_\_\_\_ Address : \_\_\_\_\_ City: \_\_\_\_\_

State/Province: \_\_\_\_\_ Postal Code: \_\_\_\_\_ Phone Number: (\_\_\_\_) - \_\_\_\_\_

E-mail Address: \_\_\_\_\_

\*Model Number: \_\_\_\_\_ \*Serial Number: \_\_\_\_\_

Purchase Date: \_\_\_\_ - \_\_\_\_ - \_\_\_\_ Place of Purchase: \_\_\_\_\_

*\*Model Number and Serial Number are located on silver label on back of unit.*



**Masterbuilt Manufacturing, LLC**  
**1 Masterbuilt Ct.**  
**Columbus, GA 31907**  
**Masterbuilt Customer Service**  
**1-800-215-7204**  
**[www.masterbuilt.com](http://www.masterbuilt.com)**



**BE A PART OF OUR “DADGUM GOOD” COMMUNITY ONLINE:**

**[www.masterbuilt.com](http://www.masterbuilt.com)**