



Vendor Stock NO.: XG1910200103

24-INCH HEAVY-DUTY CHARCOAL GRILL

ASSEMBLY INSTRUCTION MANUAL



FOR OUTDOOR USE ONLY.





**PLEASE READ INSTRUCTIONS CAREFULLY BEFORE ASSEMBLY
RETAIN THIS MANUA FOR FUTURE REFERENCE.**



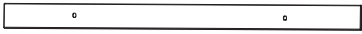
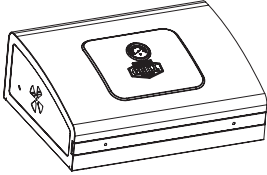
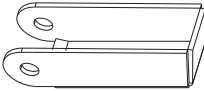
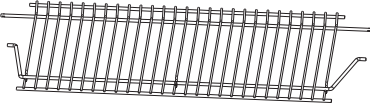
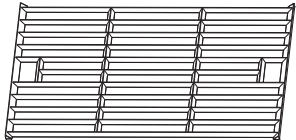
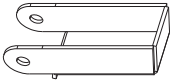
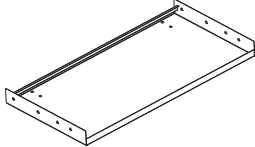
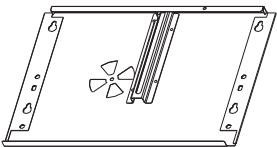
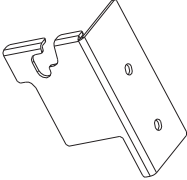

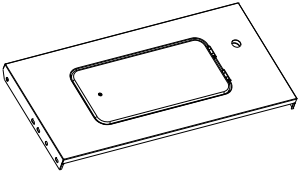
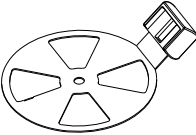
If you have any questions or problems, you can contact with our customer service at 1-866-206-0888 or login www.mecanair.net from 8:00am to 4:30pm eastern time , Monday through Friday for assistance.

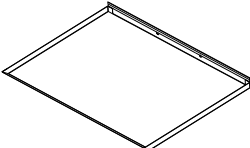
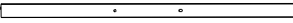
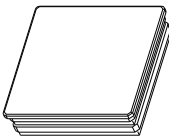
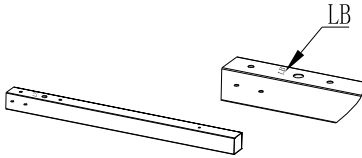
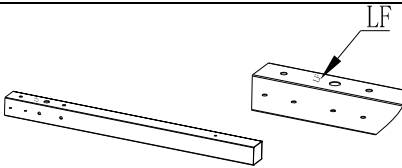

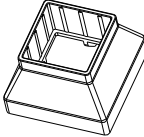

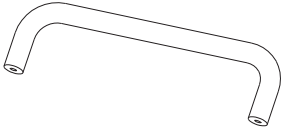
DO NOT RETURN TO THE PLACE OF PURCHASE.

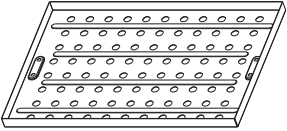
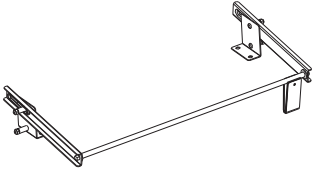
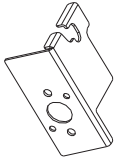
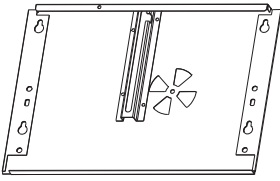
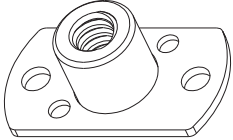
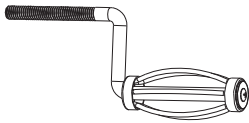
Parts List with graphic

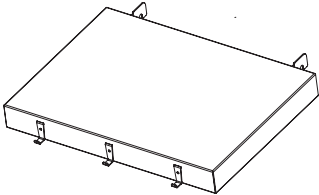
No.	Description	Part Image	QTY	Part#
1	※Temperature Gauge		1pc	17221701
2	※Lid Decorative Plate		1pc	17221702
3	Hood Assembly		1pc	17221703
4	Upper Hood Hinge		2pcs	17221704
5	Warming Rack		1pc	17221705
6	Cooking Grid		2pcs	17221706
7	Lower Hood Hinge		2pcs	17221707
8	Fire Box Back Panel		1pc	17221708
9	Fire Box Left Panel		1pc	17221709
10	Left Shaft Support Bracket		1 pc	17221710

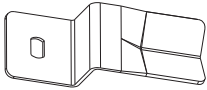
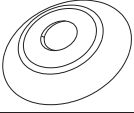
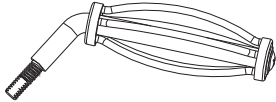

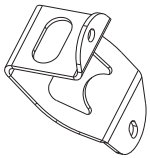
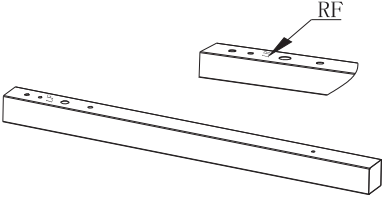
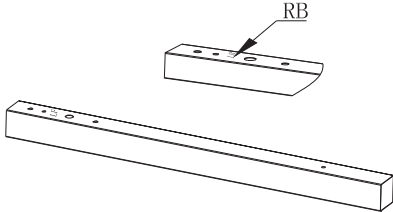

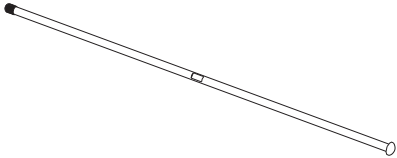
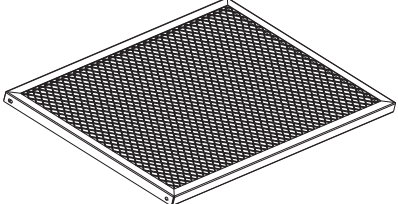

No.	Description	Part Image	QTY	Part#
11	Fire Box Front Panel with charcoal door (pre-assembled)		1pc	17221711
12	Butterfly Damper		4pcs	17221712
13	※Butterfly Damper Handle		4pcs	17221713
14	Ash Pan		1pc	17221714
15	※Ash Pan Decorative Plate		1pc	17221715
16	※Large Pipe Plug		4pcs	17221716
17	Left Back Leg		1pc	17221717
18	Left Front Leg		1pc	17221718
19	Cart Handle		1pc	17221719
20	Leg End Cap		2pcs	17221720

No.	Description	Part Image	QTY	Part#
21	Hood Handle		1pc	17221721
22	Spacers		4pcs	17221722
23	Charcoal Tray		1pc	17221723
24	Shaft Assembly		1pc	17221724
25	Right Shaft Support Bracket		1pc	17221725
26	Fire Box Right Panel		1pc	17221726
27	※Handle Locking Bracket		1pc	17221727
28	Crank Handle		1pc	17221728
29	※Handle Grip		2pcs	17221729
30	Side Shelf		1pc	17221730

No.	Description	Part Image	QTY	Part#
31	Door Locking Lever		1pc	17221731
32	Trim		1pc	17221732
33	Charcoal Door Handle		1pc	17221733
34	Ash Pan Handle		1pc	17221734
35	Bottle Opener		1pc	17221735
36	Right Front Leg		1pc	17221736
37	Right Back Leg		1pc	17221737
38	Wheel		2pcs	17221738
39	Axle		1pc	17221739
40	Bottom Shelf		1pc	17221740

※ : NO ASSEMBLY REQUIRED

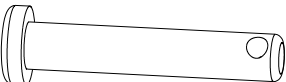
HARDWARE KIT

No.	Description	Part Image	QTY
A	M6x12 mm Screw		22pcs
B	M6x35 mm Screw		8pcs
C	M6 Shoulder Screw		4pcs
D	M10 Nut		1pc
E	Hinge Pin		2pcs
F	Cotter Pin		2pcs

ASSEMBLY PREPARATION

Before beginning assembly of product, make sure all parts are present. Inspect contents of box to make sure all parts are included and not damaged. If any part is missing or damaged, do not attempt to assemble the product.

NOTE: Some parts come with screws pre-installed. Loosen and tighten for final assembly.

Estimated Assembly Time: 1 hour by two people

Tools required for assembly:

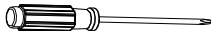
* Phillips Head Screwdriver 1pc (not included);  1 PC

* Wrench 1pc (not included)  1 PC

* Plier 1pc (not included)  1 PC

ASSEMBLY INSTRUCTIONS

IMPORTANT: ASSEMBLE ON FLAT AND SOFT SURFACE TO AVOID SCRATCHING.

1. Loosen pre-assembled Screws and leave the screw heads protruding approximately 1/5 inch. Hang the side panels onto the screws and tighten them as shown.

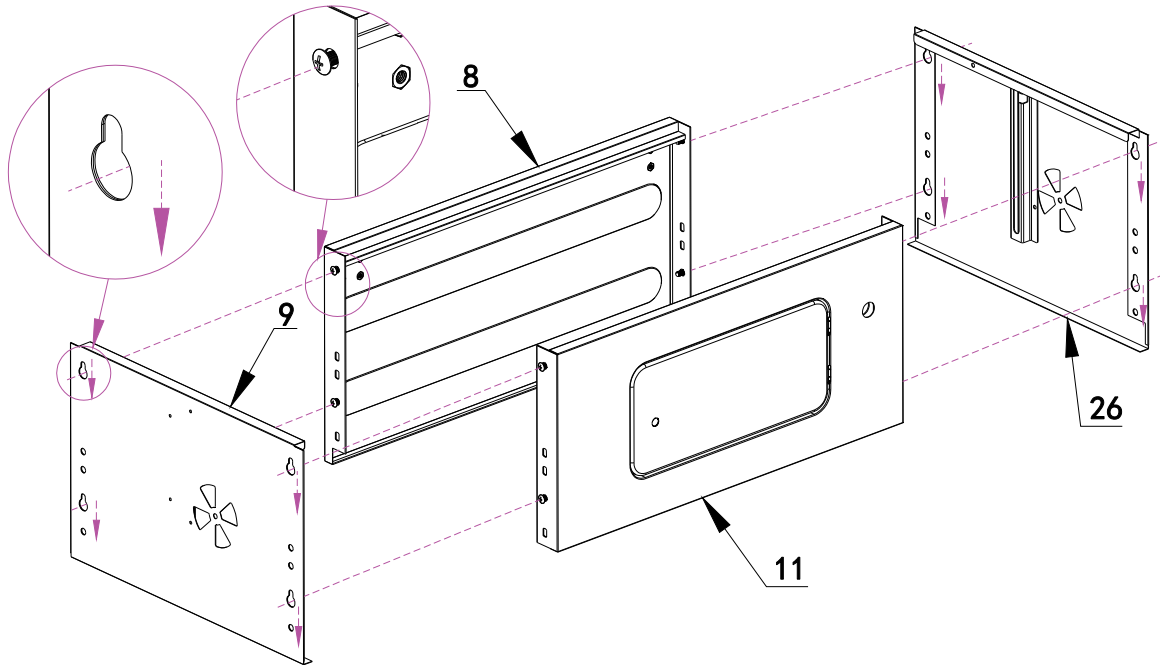

2. Put Leg End Cap (20) into Left Back Leg (17) and Left Front Leg (18). Make sure the Leg End Cap is locked into the square hole on the legs.

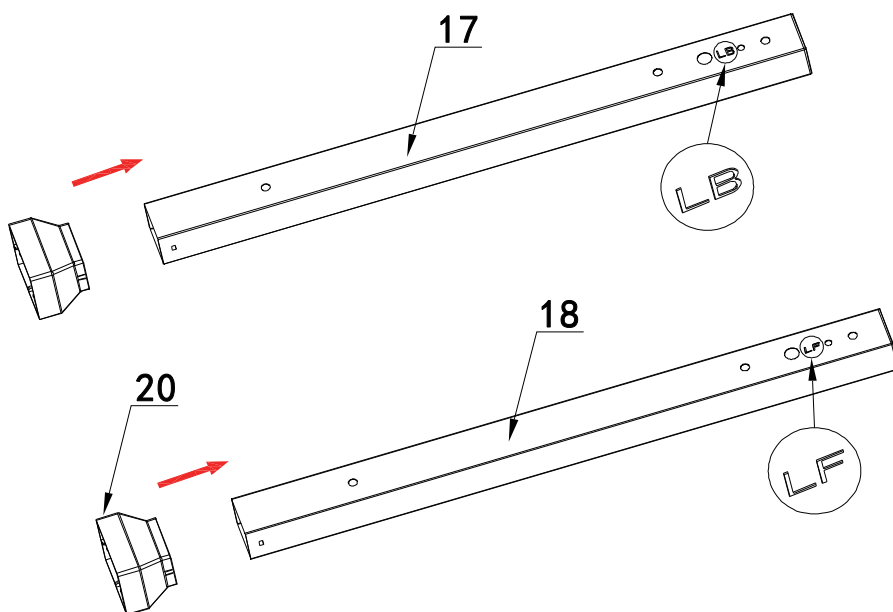

3. Use 8pcs A screws to attach legs to each corner of the Firebox as shown.

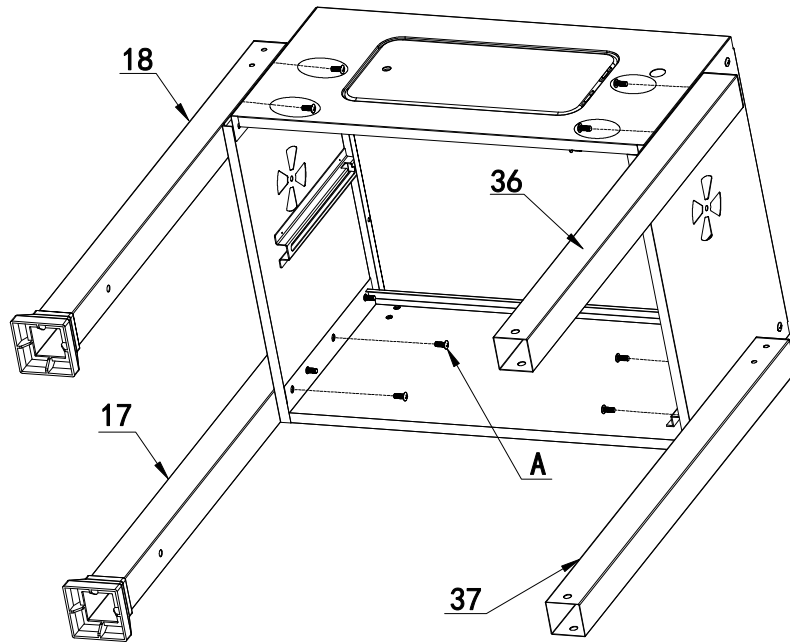

A M6X12 mm Screw  **X 8**

4. Use 4pcs A Screws to attach the Bottom Shelf (40) to the 4 Legs.

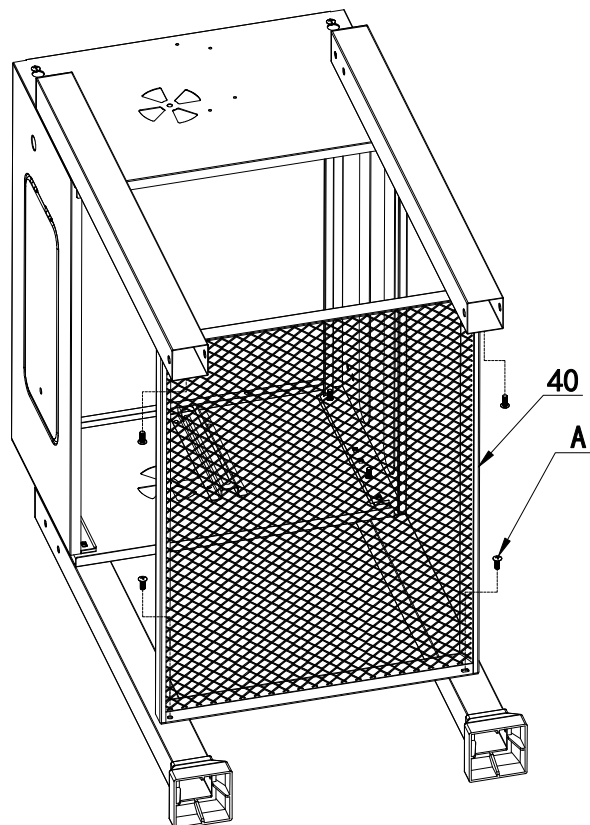

A M6X12 mm Screw  **X 4**

- Thread Axle (39) through the Wheels (38), Right Left Leg and Right Back Leg, and then fasten D Nut as shown.

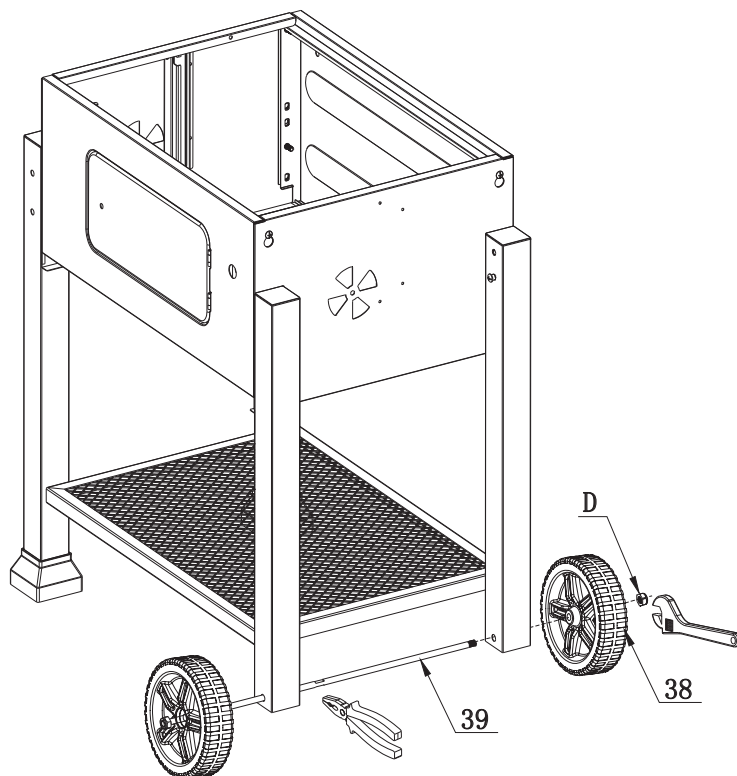

D M10 NUT



X 1

- Remove the pre-assembled Self-Tapping Bolt from the tip of Crank Handle and loosen the handle from the bracket.

Use 2pcs A Screws to attach the Right Shaft Support Bracket (25) together with Handle Locking Bracket (27) from inside of Firebox front panel.

Note: Retain the removed Self-Tapping Bolt for use in next step.

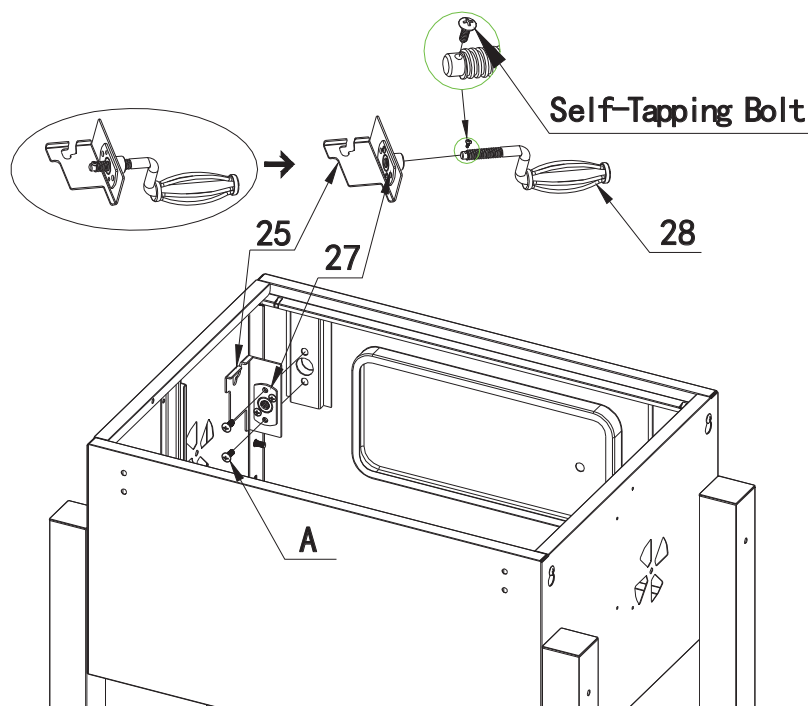

A M6X12 mm Screw

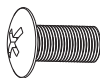

X 2

7. Rotate the Crank Handle (28) into the hole of the front panel and then fasten the Self-Tapping Bolt to the end of the Crank Handle (28).

Note: Make sure to rotate the crank handle counterclockwise completely to the end.

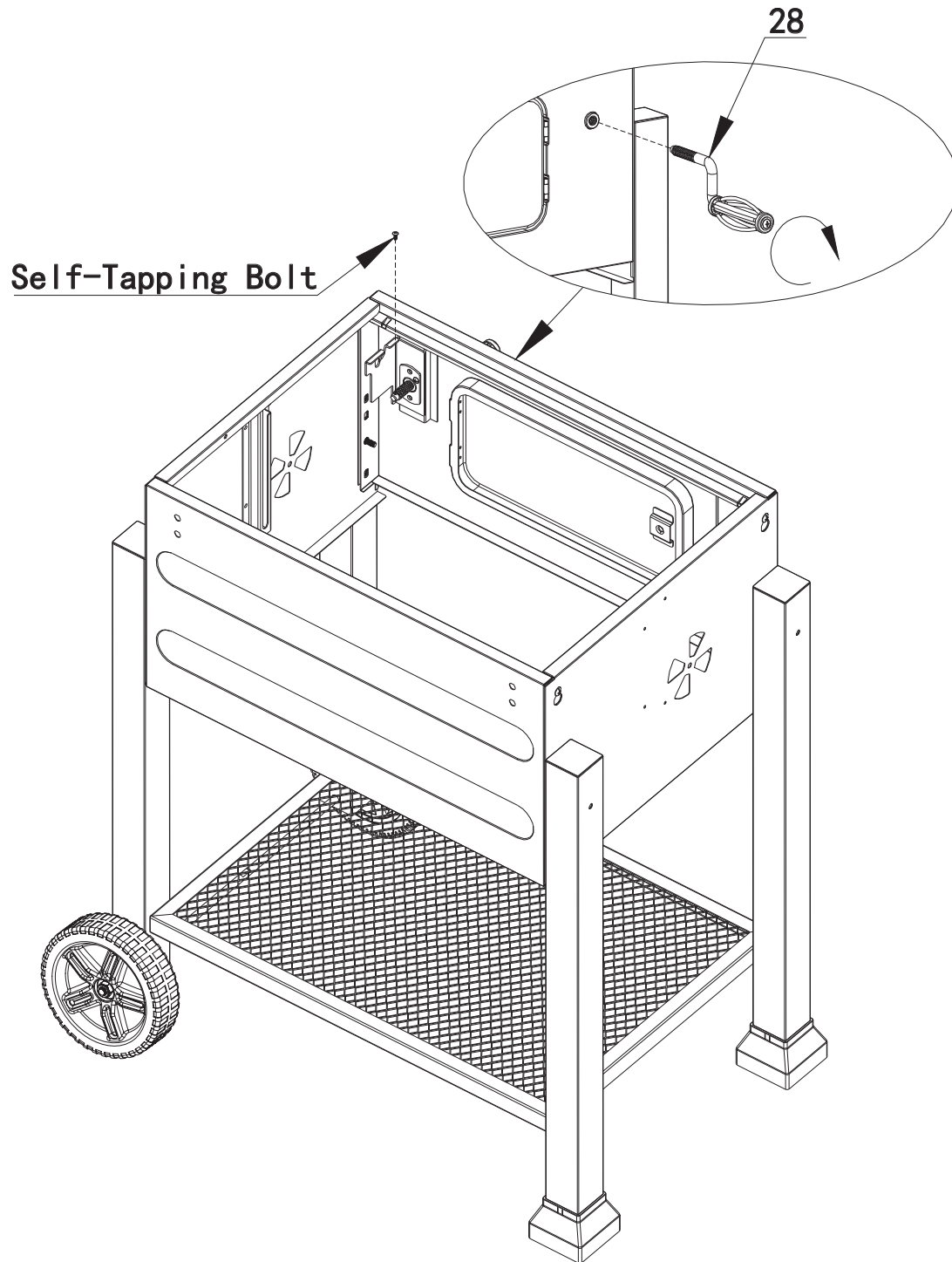

8. Use 2pcs A screws to attach the Left Shaft Support Bracket (10) to the Firebox.

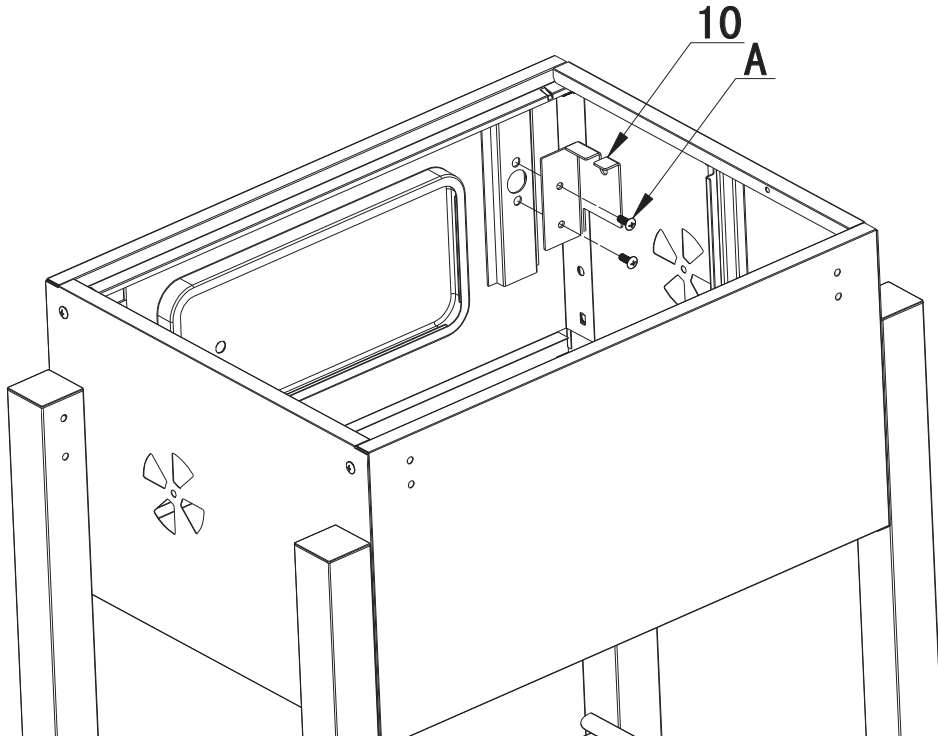

A M6X12 mm Screw

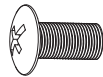

X 2

9. Loosen the pre-assembled M6x70 screws from Cart Handle (19), and then assemble the handle together with spacer (22) to the Left side of the Cart according to the diagram as shown.

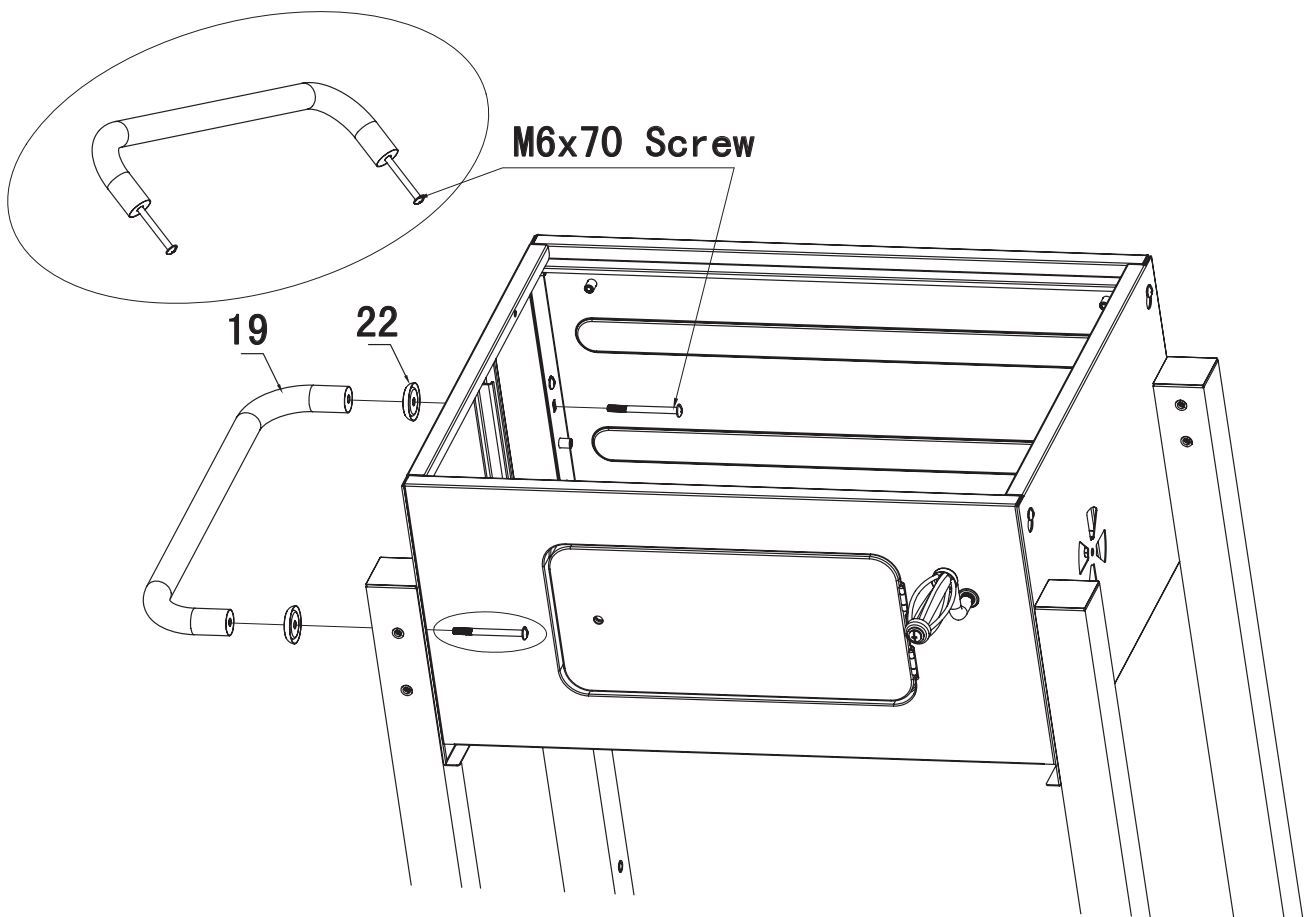

M6x70 Screw

19

22

10. Put the Bolts of the Shaft Assembly (24) into the slot of the Left & Right Fire box side panel. Fit the shaft onto the slot of the bracket of the fire box front panel.

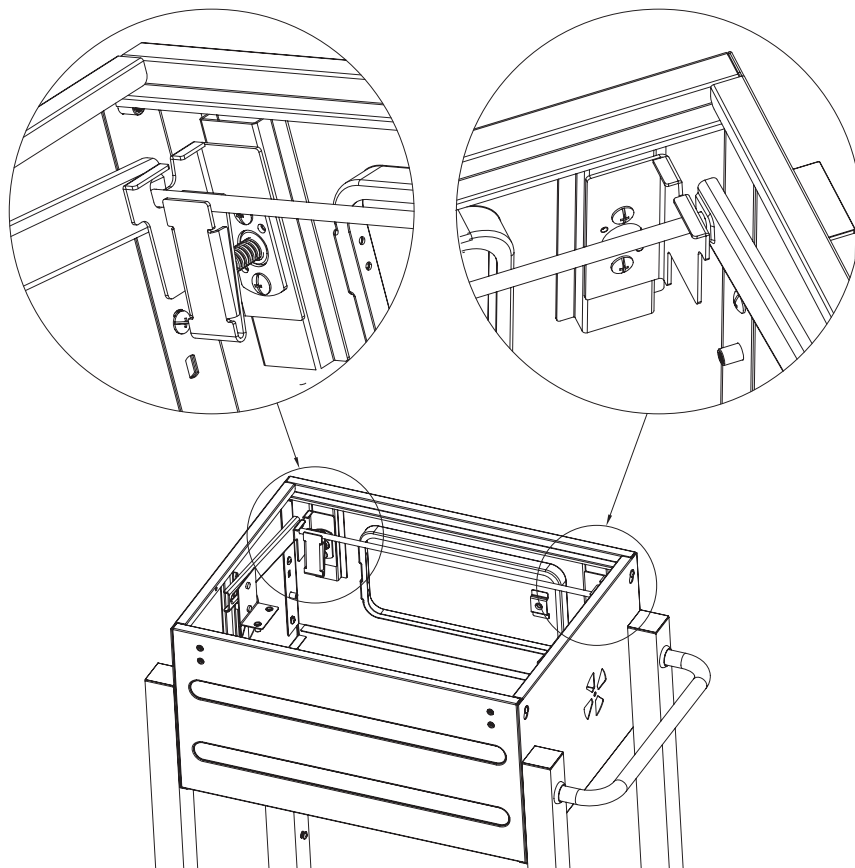
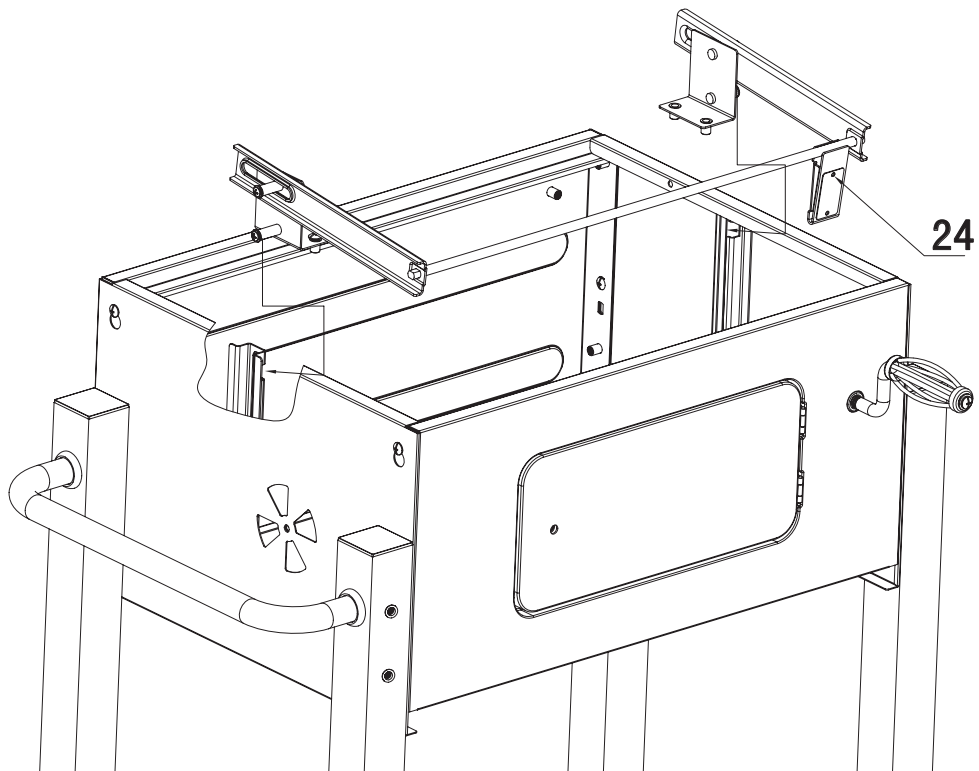

11. Loosen the pre-assembled M6 screws, $\Phi 6$ Spring Washers and M6 Nuts from Butterfly Dampers (12), and then assemble the Butterfly Dampers to the side of Fire Box according to the diagram as shown.

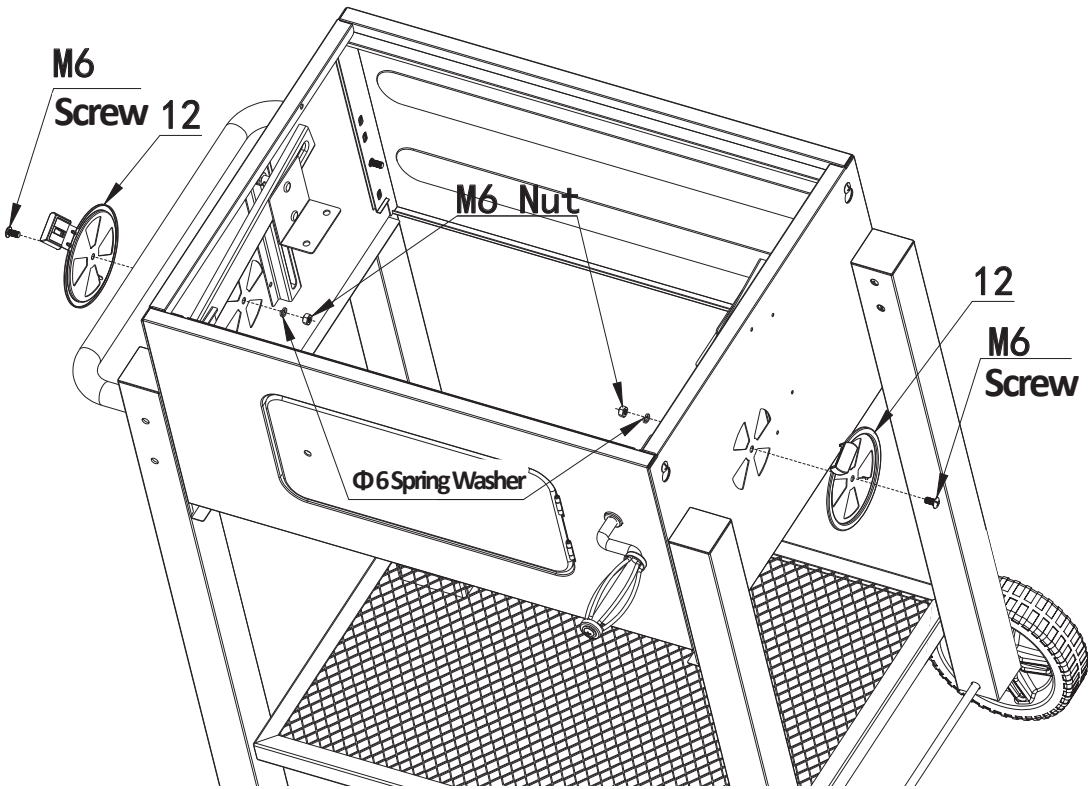

12. Align the holes of the charcoal pan (23) with the holes on Shaft Assembly brackets, and install the charcoal pan (23) onto the brackets by tightening 4pcs A crews as shown.

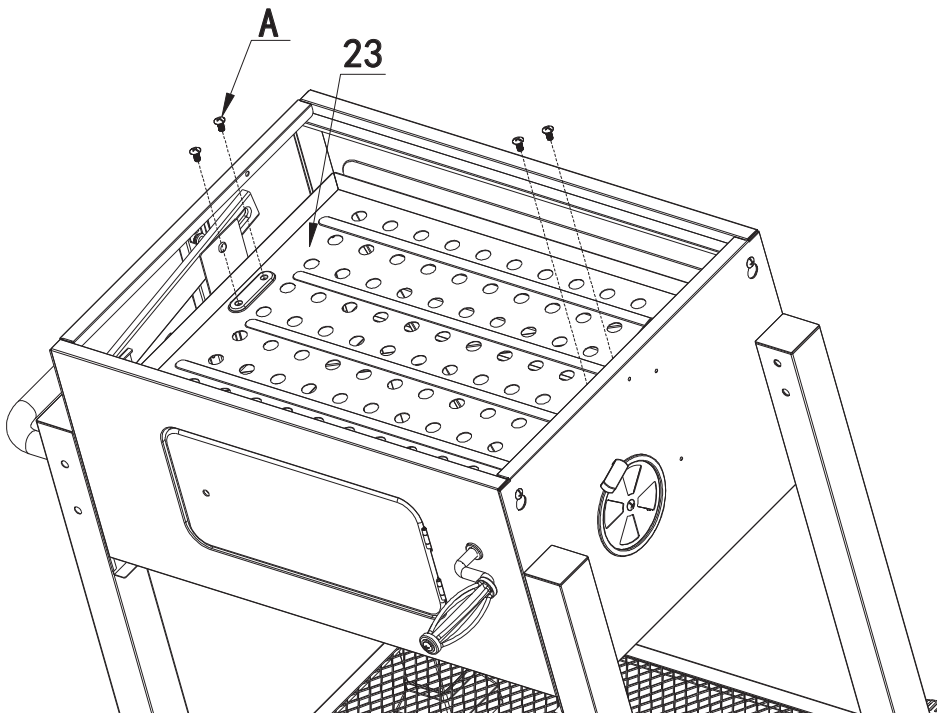

A M6X12 mm Screw

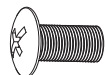

X 4

13. Loosen the pre-assembled M8 Nut and spring washer from the handle (33), and then assemble the handle to Charcoal Door according to the diagram as shown.

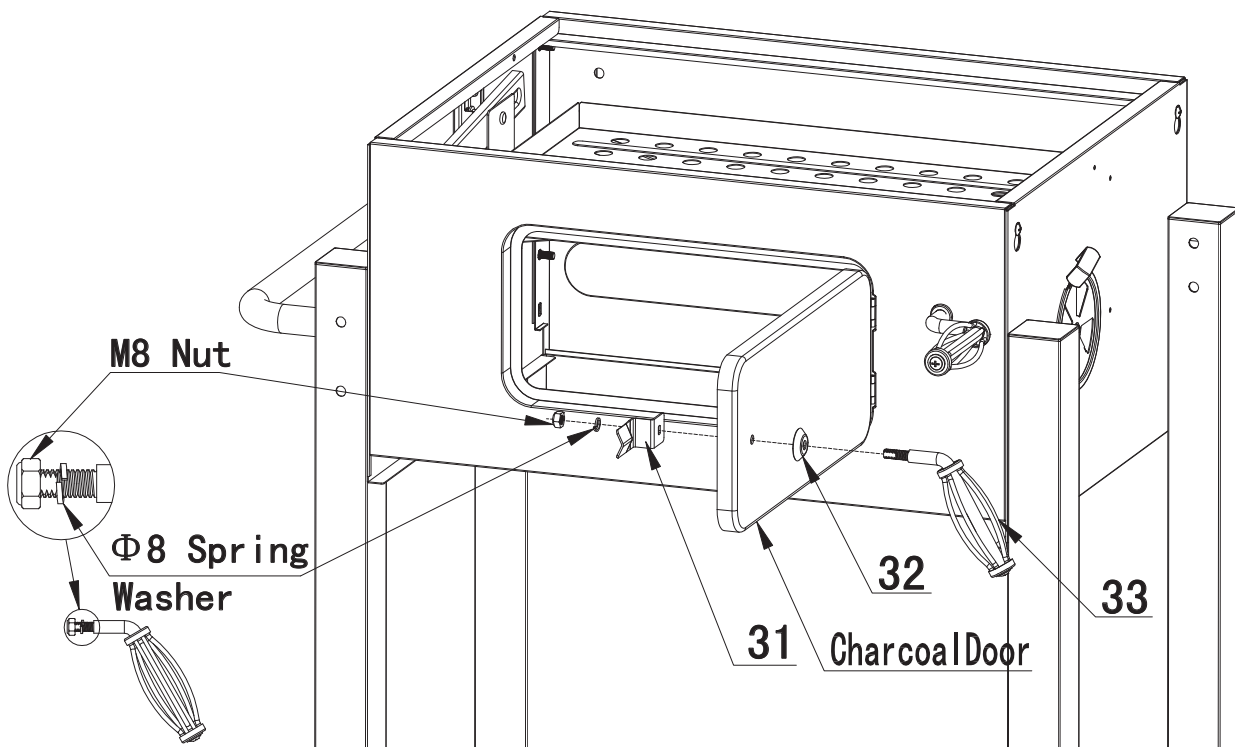

14. Use 4pcs B screws to attach Lower Hood Hinges (7) to the firebox back panel.

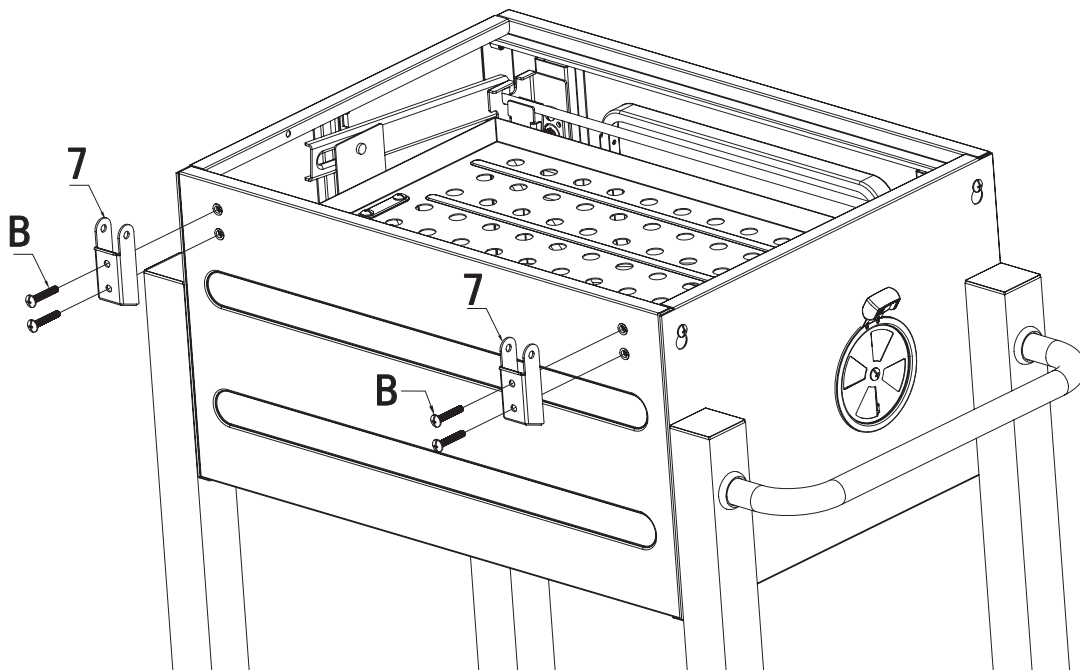

B M6X35 mm Screw  **X 4**

15. Use 2pcs A screws to attach Bottle Opener (35) to Left Front Leg.

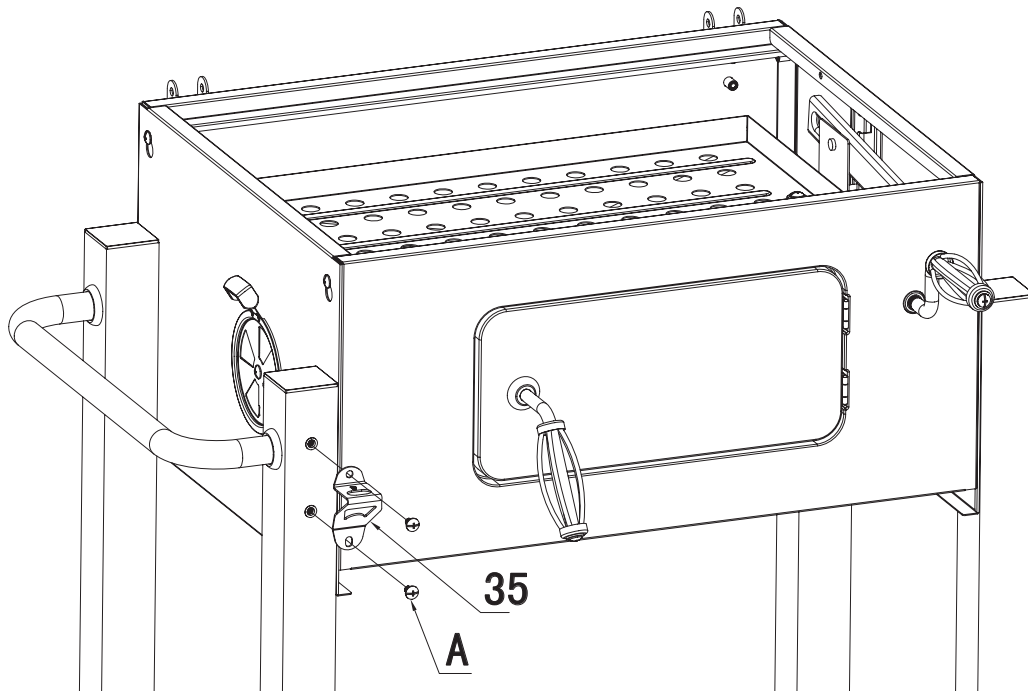

A M6X12 mm Screw  **X 2**

16. Place the Cooking Grates (6) inside the firebox as shown.

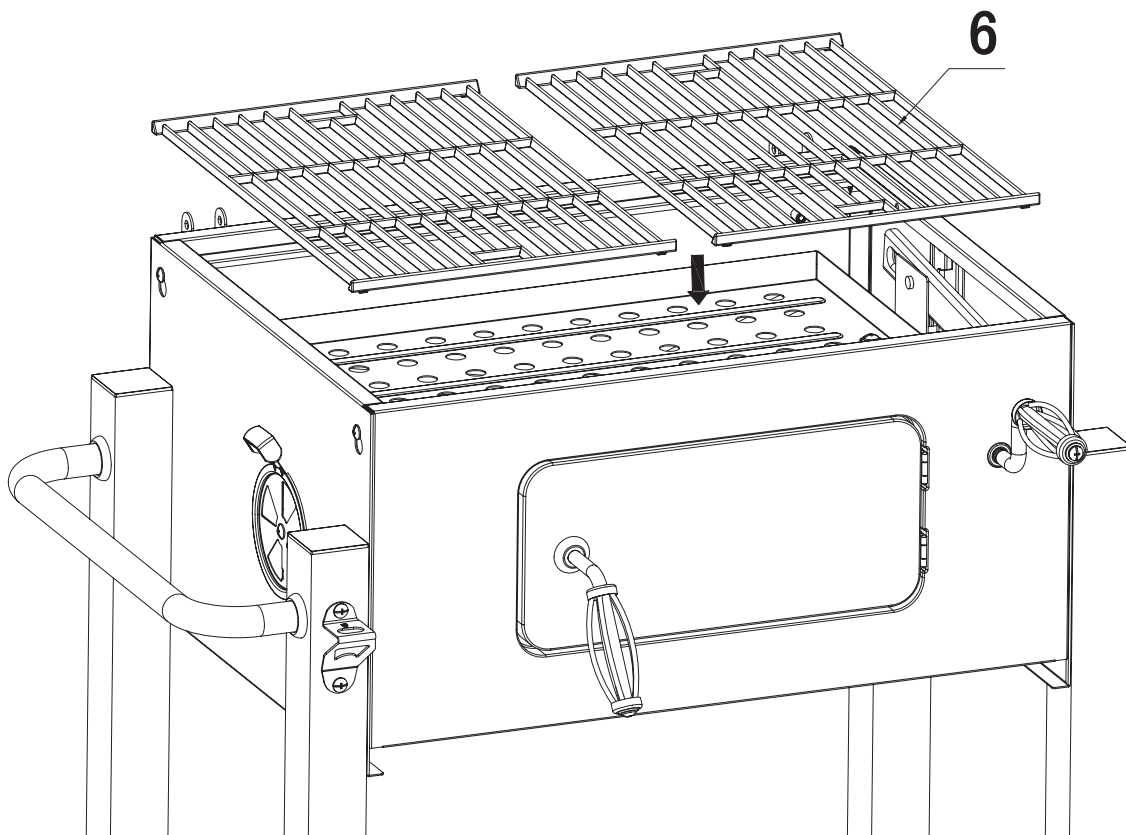

17. Use 4pcs B screws to attach Upper Hood Hinges (4) to the back of the Hood.

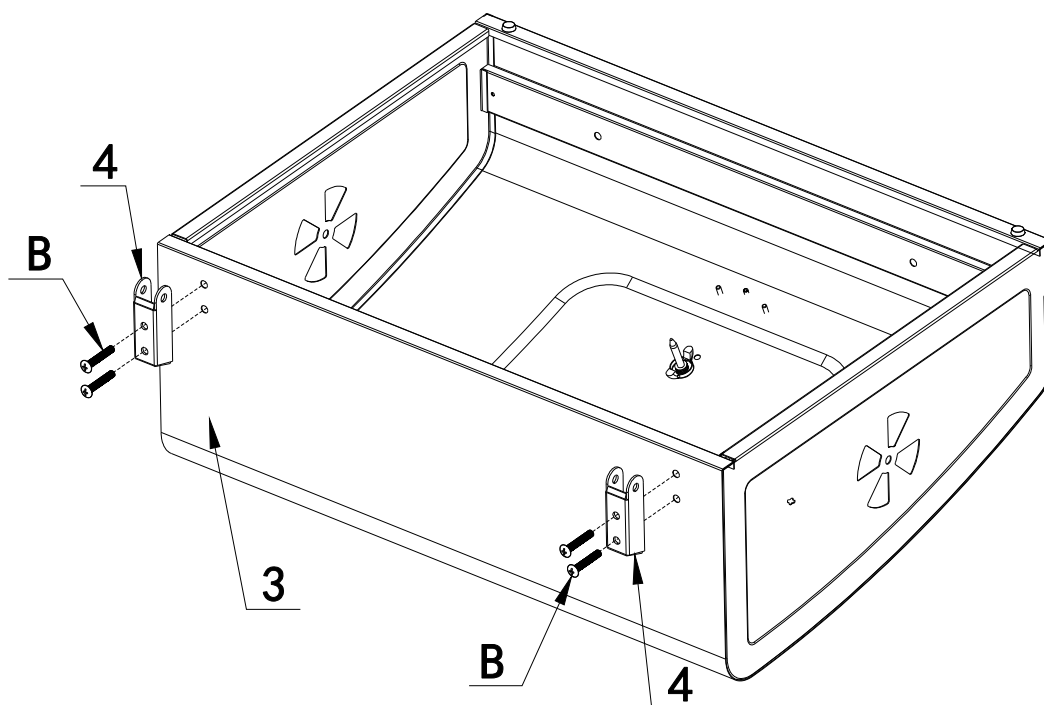

B M6X35 mm Screw  **X 4**

18. Loosen the pre-assembled M6 screws, $\Phi 6$ Spring Washers and M6 Nuts from Butterfly Dampers (12), and then assemble the Butterfly Dampers to both sides of Hood according to the diagram as shown.

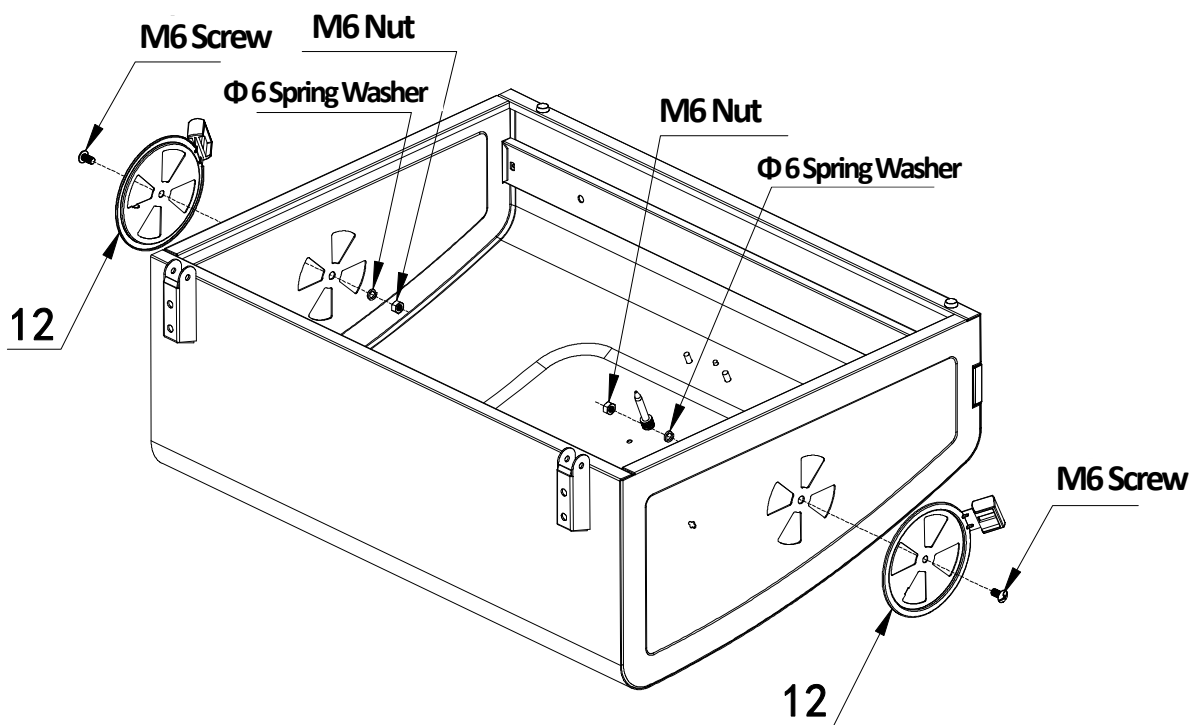

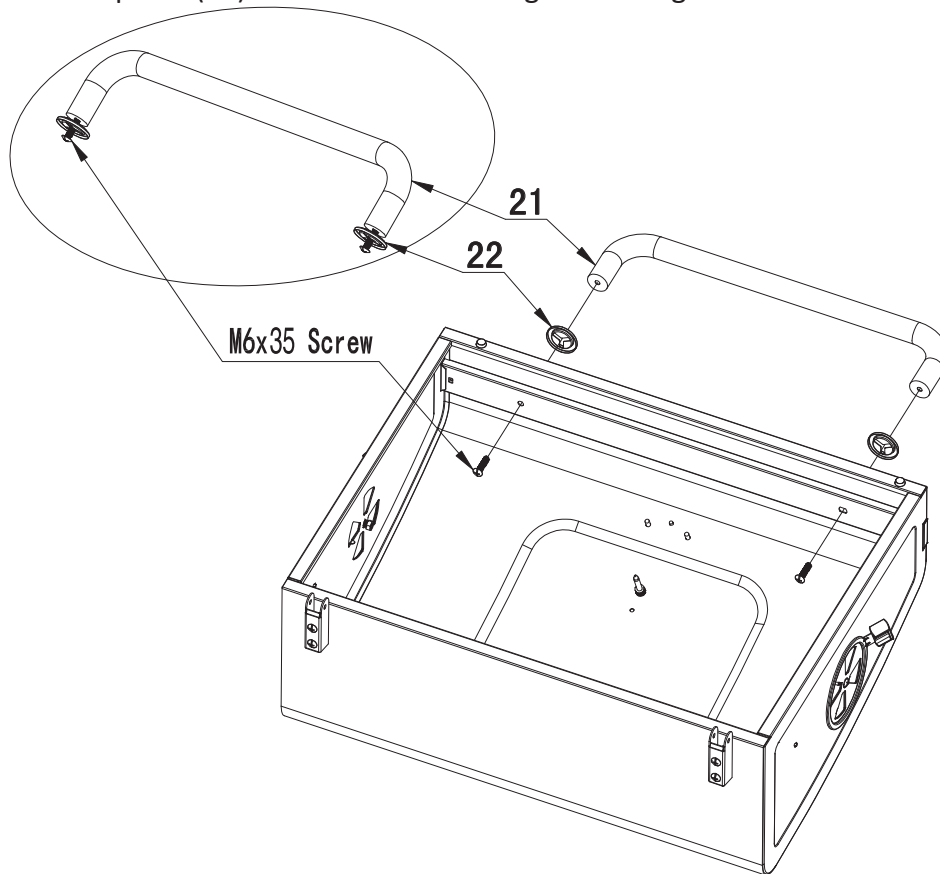

19. Loosen the pre-assembled M6x35 screws from Hood Handle (21), and then assemble the handle together with spacer (22) to the hood according to the diagram as shown.

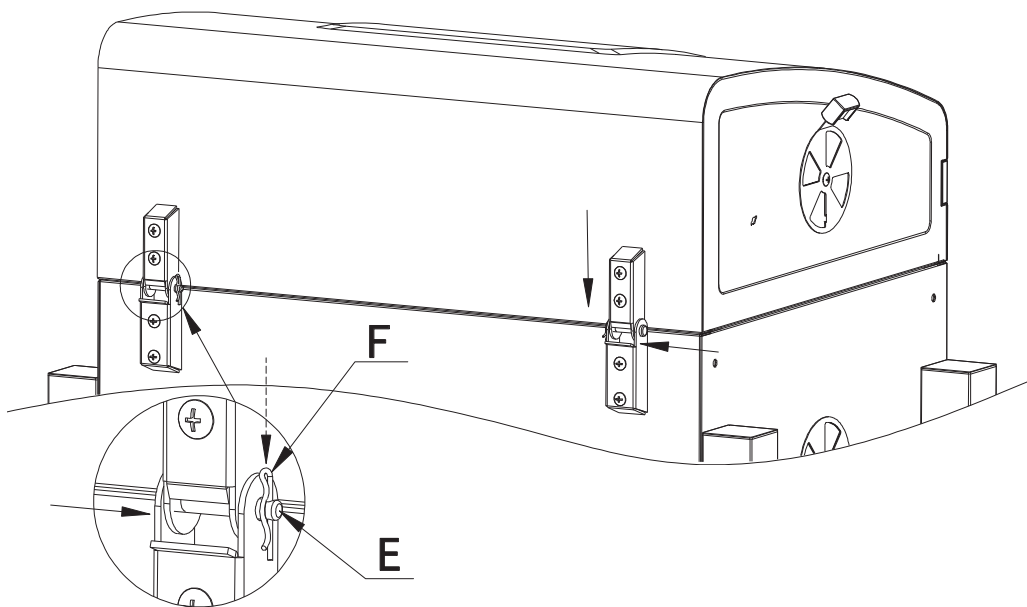

20. Position Hood onto Firebox with hinges aligned as shown. Insert Hinge Pins (E) through hinges. Secure hinge pins with Cotter Pins (F)



- | | | | |
|----------|-------------------|---|------------|
| E | Hinge Pin |  | X 2 |
| F | Cotter Pin |  | X 2 |

21. Insert M6 Shoulder Screw (C) into the top hole of each leg as shown. Tighten screws to leave the screws head protruding approximately 1/5 inch.

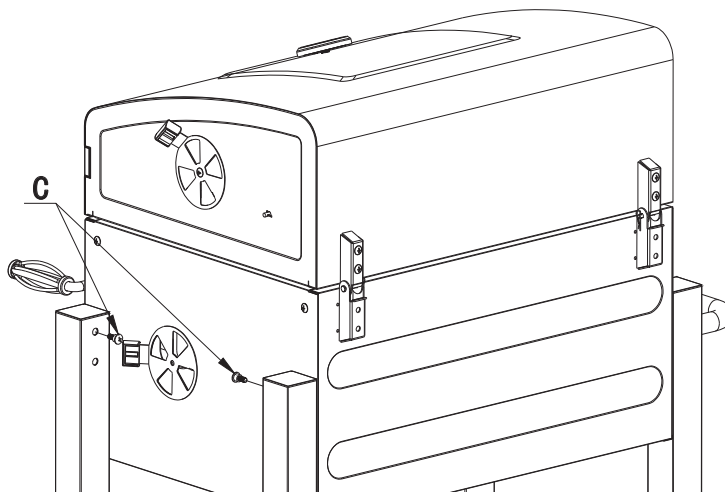

Hang the Side Shelf Brackets onto the protruding bolt heads, and then fully tighten screws as shown.

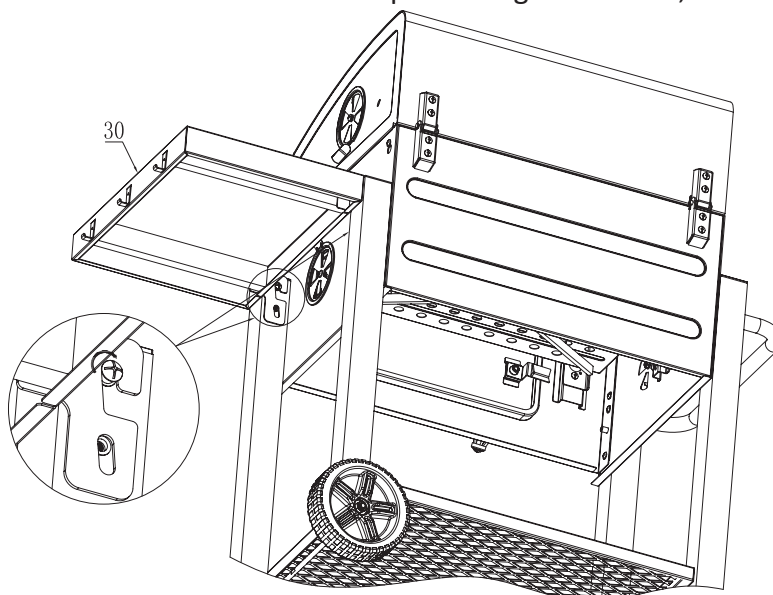

Insert M6 Shoulder Screw (C) into the lower holes of side shelf bracket and fully tighten screws as shown below.

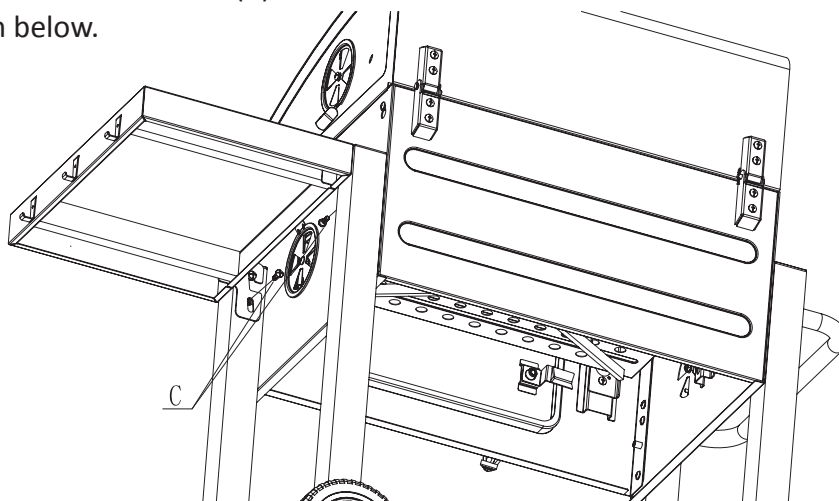

C M6 shoulder screw  **X 4**

22. Loosen the pre-assembled M5x12 Screws from Ash Pan Handle (34), and then assemble the handle to Ash Pan (14) according to the diagram as shown. Then insert the Ash Pan under the Firebox as shown.

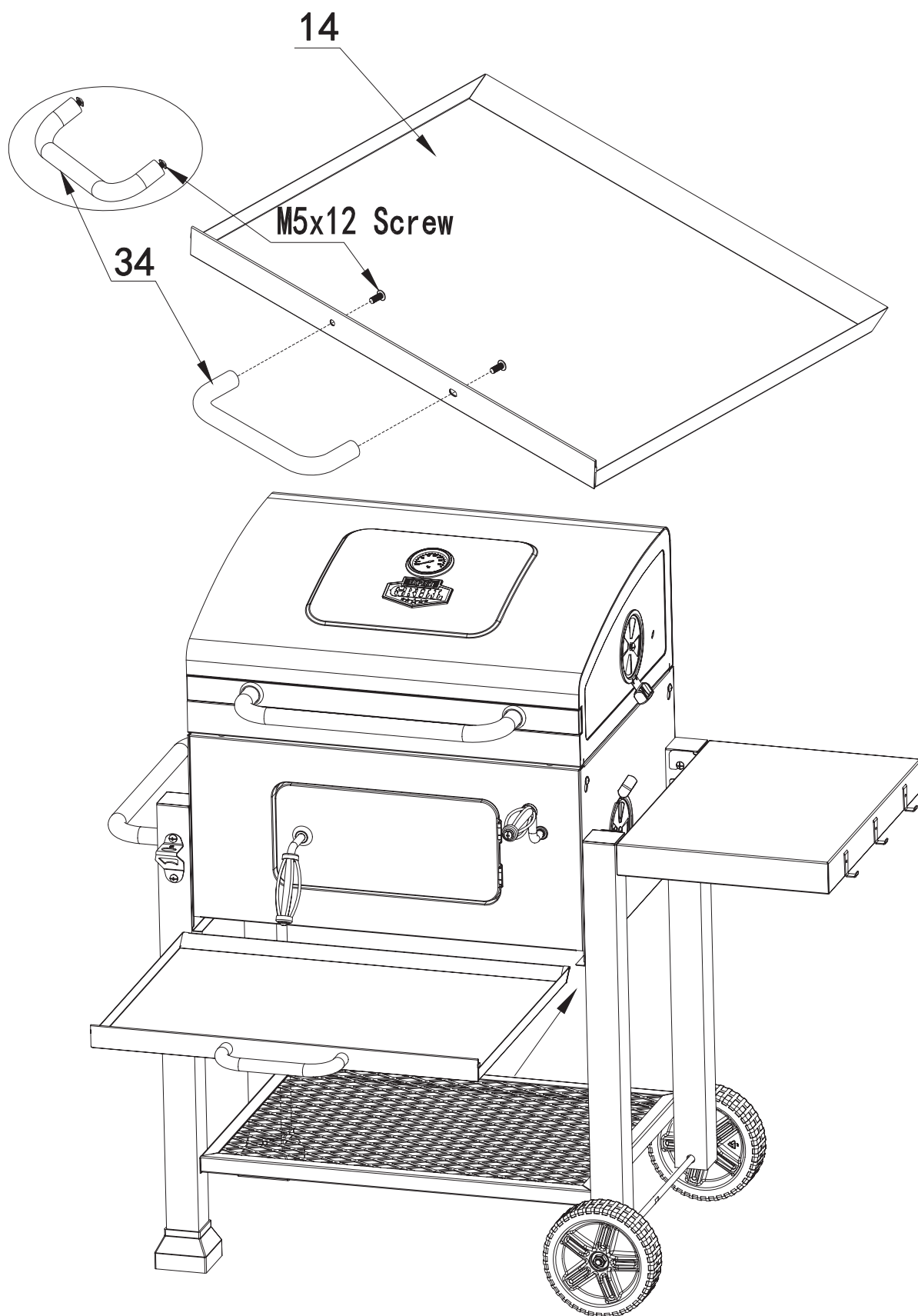

23. Install the Warming Rack as shown.

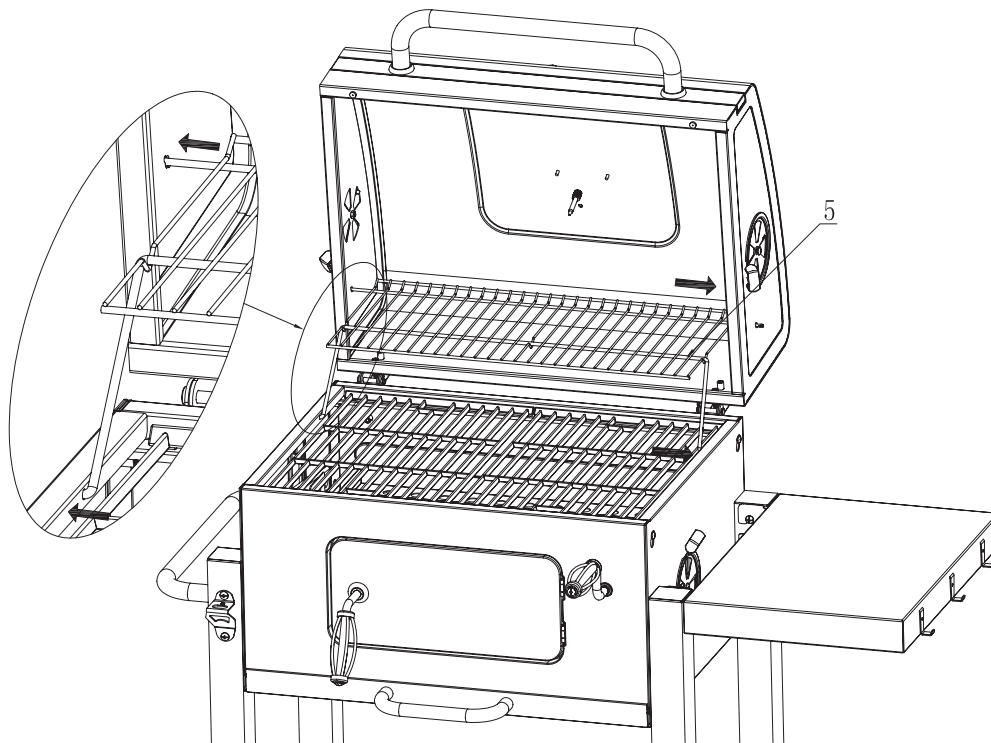

24. Assembly is completed.

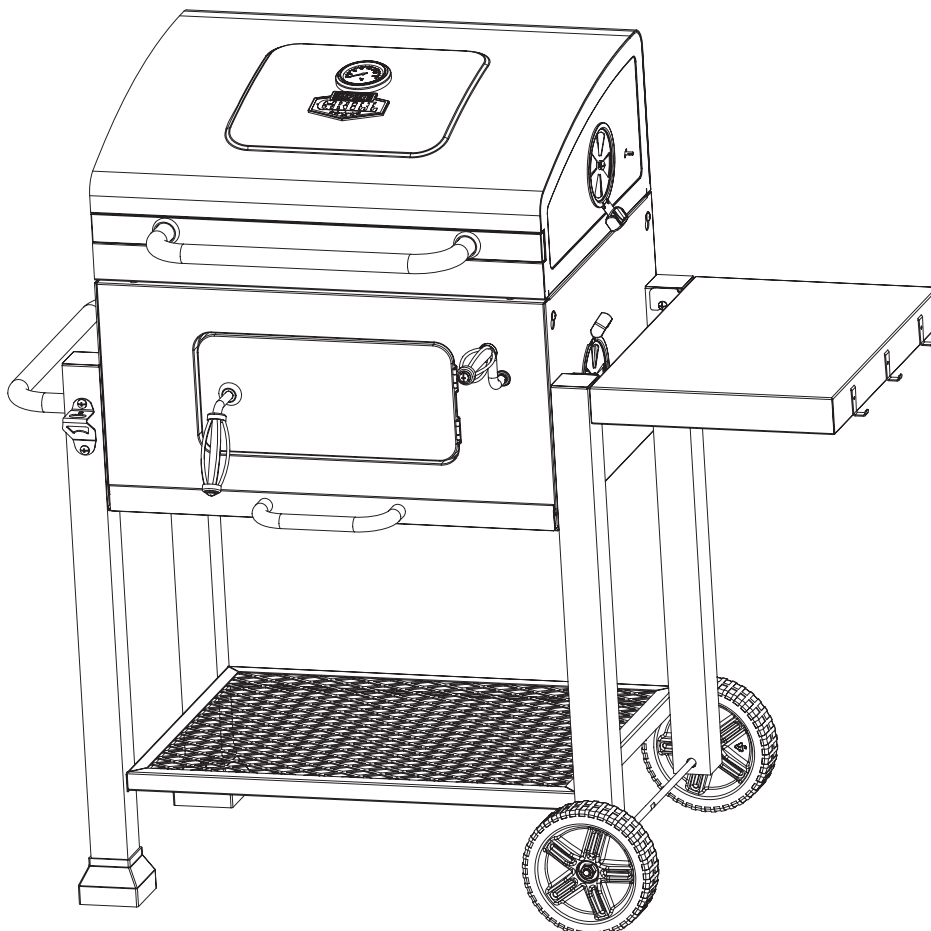

2-YEAR LIMITED WARRANTY

This warranty is non-transferable and does not cover failures due to misuse of improper installation or maintenance.

This warranty is for replacement of defective parts only. We are not responsible for incidental or consequential damages or labor costs.

This warranty does not cover corrosion or discoloration after the grill is used, or lack of maintenance, hostile environment, accidents, alterations, abuse or neglect.

This warranty does not cover damage caused by heat, abrasive and chemical cleaners, or any damage to other components used in the installation or operation of the charcoal grill. And paint is not warranted and may require touch-up.

Some states do not allow the limitation or exclusion of incidental or consequential damages, so the above limitations or exclusions may not apply to you. This warranty gives you specific legal rights, and you may also have other rights that vary from state to state.

DO NOT RETURN TO STORE

For service regarding this warranty, call our Customer Service Department at 1-866-206-0888 from 8:00am to 4:30pm eastern time, Monday through Friday for assistance. Proof of purchase in the form of an original receipt with date of purchase is required.

DO NOT ship parts or units without a return authorization number. Upon receipt of an authorization number, the product must be shipped prepaid.

Distributed by:

Wal-Mart Stores, Inc.,
Bentonville, AR 72716

Manufacturer:

GUANGDONG DEHE TECHNOLOGY CO.,LTD
Yutang Road No. 9, Heshan Industrial Park, Gonghe, Heshan
City, Guangdong 529728, China
Please call 1-866-206-0888 for any assistance

V02