

OPERATOR'S MANUAL

DieHard®

Portable Power 1150



**Model No.
28.71988**

CAUTION

**Read and follow all Safety
Rules and Operating Instructions
before Every Use of this Product.**

SAVE THESE INSTRUCTIONS.

Sears Brands Management Corporation, Hoffman Estates, IL 60179 U.S.A.

00-99-001002/0710

TABLE OF CONTENTS

SECTION	PAGE
IMPORTANT SAFETY INSTRUCTIONS	2
PERSONAL PRECAUTIONS	3
FOLLOW THESE STEPS WHEN CONNECTING TO A BATTERY	4
GROUNDING AND AC POWER CORD CONNECTIONS	5
ASSEMBLY INSTRUCTIONS	5
FEATURES	6
CHARGING THE INTERNAL BATTERY OF THE JUMP STARTER	6
OPERATING INSTRUCTIONS	7
MAINTENANCE INSTRUCTIONS	12
MOVING AND STORAGE INSTRUCTIONS	13
TROUBLESHOOTING	13
SPECIFICATIONS	14
REPLACEMENT PARTS/ACCESSORIES	14



CONTAINS SEALED NON-SPILLABLE LEAD-ACID BATTERY. MUST BE DISPOSED OF PROPERLY.

WARNING: Possible explosion hazard. Contact with battery acid may cause severe burns and blindness. Keep out of reach of children.

DIEHARD ONE-YEAR FULL WARRANTY

When operated and maintained according to all supplied instructions, if this DieHard product fails due to a defect in material or workmanship within 1 year from the date of purchase, return it to any DieHard outlet in the United States for free replacement.

This warranty does not include light bulbs, or the inflator hose and adapters, which are expendable parts.

This warranty gives you specific legal rights, and you may also have other rights which vary from state to state.

Sears Brands Management Corporation, Hoffman Estates, IL 60179

**FOR CUSTOMER ASSISTANCE OR REPLACEMENT PARTS,
CALL TOLL-FREE FROM 7 AM TO 5 PM CT
MONDAY THROUGH FRIDAY: 1-800-732-7764**

IMPORTANT: READ AND SAVE THIS SAFETY AND INSTRUCTION MANUAL.

SAVE THESE INSTRUCTIONS – Charge the jump starter internal battery immediately after purchase, after every use and every 30 days. This manual will show you how to use your jump starter safely and effectively. Please read, understand and follow these instructions and precautions carefully, as this manual contains important safety and operating instructions. The safety messages used throughout this manual contain a signal word, a message and an icon.

The signal word indicates the level of the hazard in a situation.

⚠ DANGER Indicates an imminently hazardous situation which, if not avoided, will result in death or serious injury to the operator or bystanders.

⚠ WARNING Indicates a potentially hazardous situation which, if not avoided, could result in death or serious injury to the operator or bystanders.

⚠ CAUTION Indicates a potentially hazardous situation which, if not avoided, could result in moderate or minor injury to the operator or bystanders.

IMPORTANT Indicates a potentially hazardous situation which, if not avoided, could result in damage to the equipment or vehicle or property damage.

Safety messages in this manual contain two different type styles.

- Unnumbered type states the hazard.
- Numbered type states how to avoid the hazard.

The icon gives a graphical description of the potential hazard.

⚠ WARNING



Pursuant to California Proposition 65, this product contains chemicals known to the State of California to cause cancer and birth defects or other reproductive harm.

1. IMPORTANT SAFETY INSTRUCTIONS - SAVE THESE INSTRUCTIONS -

This manual contains important safety and operating instructions

⚠WARNING



⚠WARNING



RISK OF ELECTRIC SHOCK OR FIRE.

- 1.1 Read the entire manual before using this product. Failure to do so could result in serious injury or death.
- 1.2 Keep out of reach of children.
- 1.3 Use only recommended attachments. Use of an attachment not recommended or sold by the jump starter manufacturer may result in a risk of fire, electric shock or injury to persons or damage to property.
- 1.4 Do not put fingers or hands into any of the jump starter's outlets.
- 1.5 Do not expose the jump starter to rain or snow.
- 1.6 To reduce the risk of electric shock, turn off and/or unplug the jump starter before attempting any maintenance or cleaning. Simply turning off the controls will not reduce this risk.
- 1.7 Do not operate the jump starter if it has received a sharp blow, been dropped or otherwise damaged in any way; take it to a qualified service person. (Call customer service at: 1-800-732-7764.)
- 1.8 Do not disassemble the jump starter; take it to a qualified service person when service or repair is required. Incorrect reassembly may result in a risk of fire or electric shock. (Call customer service at: 1-800-732-7764.)

⚠WARNING



RISK OF EXPLOSIVE GASES.

- 1.9 WORKING IN THE VICINITY OF A LEAD-ACID BATTERY IS DANGEROUS. BATTERIES GENERATE EXPLOSIVE GASES DURING NORMAL BATTERY OPERATION. FOR THIS REASON, IT IS OF UTMOST IMPORTANCE THAT YOU FOLLOW THE INSTRUCTIONS EACH TIME YOU USE THE JUMP STARTER.
- 1.10 To reduce the risk of a battery explosion, follow these instructions and those published by the battery manufacturer and the manufacturer of any equipment you intend to use in the vicinity of the battery. Review the cautionary markings on these products and on the engine.

2. PERSONAL PRECAUTIONS



RISK OF EXPLOSIVE GASES. A SPARK NEAR THE BATTERY MAY CAUSE A BATTERY EXPLOSION. TO REDUCE THE RISK OF A SPARK NEAR THE BATTERY:

- 2.1 Working in the vicinity of a lead-acid battery is dangerous. Batteries generate explosive gases during normal battery operation. For this reason, it is of utmost importance that you follow the instructions each time you use the jump starter.
- 2.2 NEVER smoke or allow a spark or flame in the vicinity of a battery or engine.
- 2.3 Do not permit the internal battery of the jump starter to freeze. Never charge a frozen battery.
- 2.4 To prevent sparking, NEVER allow clips to touch together or contact the same piece of metal.
- 2.5 When charging the internal battery of the jump starter, work in a well ventilated area and do not restrict the ventilation in any way.
- 2.6 Be extra cautious to reduce the risk of dropping a metal tool onto a battery. It might spark or short-circuit the battery or other electrical part that may cause an explosion.
- 2.7 Remove personal metal items such as rings, bracelets, necklaces and watches when working with a lead-acid battery. A lead-acid battery can produce a short-circuit current high enough to weld a ring or the like to metal, causing a severe burn.
- 2.8 Be sure the area around the battery is well ventilated while the jump starter is being used.



RISK OF CONTACT WITH BATTERY ACID. BATTERY ACID IS A HIGHLY CORROSIVE SULFURIC ACID.

- 2.9 Consider having someone close enough by to come to your aid when you work near a lead-acid battery.
- 2.10 Have plenty of fresh water and soap nearby in case battery acid contacts your skin, clothing or eyes.
- 2.11 Wear complete eye and body protection, including safety goggles and protective clothing. Avoid touching your eyes while working near the battery.
- 2.12 If battery acid contacts your skin or clothing, immediately wash the area with soap and water. If acid enters your eye, immediately flood the eye with cold running water for at least 10 minutes and get medical attention right away.
- 2.13 If battery acid is accidentally swallowed, drink milk, the whites of eggs or water. DO NOT induce vomiting. Seek medical attention immediately.
- 2.14 Stay clear of fan blades, belts, pulleys and other parts that may cause injury.
- 2.15 Clean the battery terminals before using the jump starter. During cleaning, keep airborne corrosion from coming into contact with your eyes, nose and mouth. Use baking soda and water to neutralize the battery acid and help eliminate airborne corrosion. Do not touch your eyes, nose or mouth.
- 2.16 Determine the voltage of the battery by referring to the vehicle owner's manual and make sure that the output voltage of the jump starter is correct.
- 2.17 Make sure that the jump starter cable clips make tight connections.

3. FOLLOW THESE STEPS WHEN CONNECTING TO A BATTERY



A SPARK NEAR THE BATTERY MAY CAUSE A BATTERY EXPLOSION. TO REDUCE THE RISK OF A SPARK NEAR THE BATTERY:

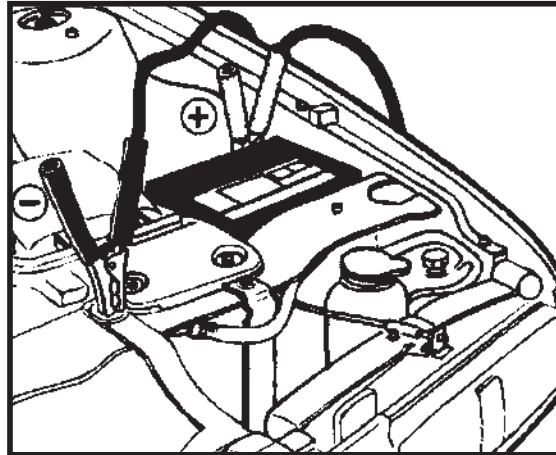

NEGATIVE GROUNDED SYSTEM

- 3.1** Attach the output cables to the battery and chassis as indicated below. Never allow the output clips to touch each other.
- 3.2** Position the DC cables to reduce the risk of damage by the hood, door and moving or hot engine parts. **NOTE:** If it is necessary to close the hood during the charging process, ensure that the hood does not touch the metal part of the battery clips or cut the insulation of the cables.
- 3.3** Stay clear of fan blades, belts, pulleys and other parts that can cause injury.
- 3.4** Check the polarity of the battery posts. The **POSITIVE (POS, P, +)** battery post usually has a larger diameter than the **NEGATIVE (NEG, N, -)** post.
- 3.5** Determine which post of the battery is grounded (connected) to the chassis. If the negative post is grounded to the chassis (as in most vehicles), see step 3.6. If the positive post is grounded to the chassis, see step 3.7.
- 3.6** For a negative-grounded vehicle, connect the **POSITIVE (RED)** clip from the jump starter to the **POSITIVE (POS, P, +)** ungrounded post of the battery. Connect the **NEGATIVE (BLACK)** clip to the vehicle chassis or engine block away from the battery. Do not connect the clip to the carburetor, fuel lines or sheet-metal body parts. Connect to a heavy gauge metal part of the frame or engine block.
- 3.7** For a positive-grounded vehicle, connect the **NEGATIVE (BLACK)** clip from the jump starter to the **NEGATIVE (NEG, N, -)** ungrounded post of the battery. Connect the **POSITIVE (RED)** clip to the vehicle chassis or engine block away from the battery. Do not connect the clip to the carburetor, fuel lines or sheet-metal body parts. Connect to a heavy gauge metal part of the frame or engine block.
- 3.8** When disconnecting the jump starter, turn all switches to off (if applicable), remove the clip from the vehicle chassis and then remove the clip from the battery terminal.

4. GROUNDING AND AC POWER CORD CONNECTIONS



RISK OF ELECTRIC SHOCK OR FIRE.

- 4.1 The jump starter charger is for use on a nominal 120-volt circuit. The plug must be plugged into an outlet that is properly installed and grounded in accordance with all local codes and ordinances. The plug pins must fit the receptacle (outlet). Do not use with an ungrounded system.

- 4.2 **DANGER** Never alter the AC cord or plug provided – if it does not fit the outlet, have a proper grounded outlet installed by a qualified electrician. An improper connection can result in a risk of an electric shock or electrocution.
NOTE: Pursuant to Canadian Regulations, use of an adapter plug is not allowed in Canada. Use of an adapter plug in the United States is not recommended and should not be used.

5. ASSEMBLY INSTRUCTIONS

Remove all cord wraps and uncoil the cables prior to using the jump starter.

6. FEATURES

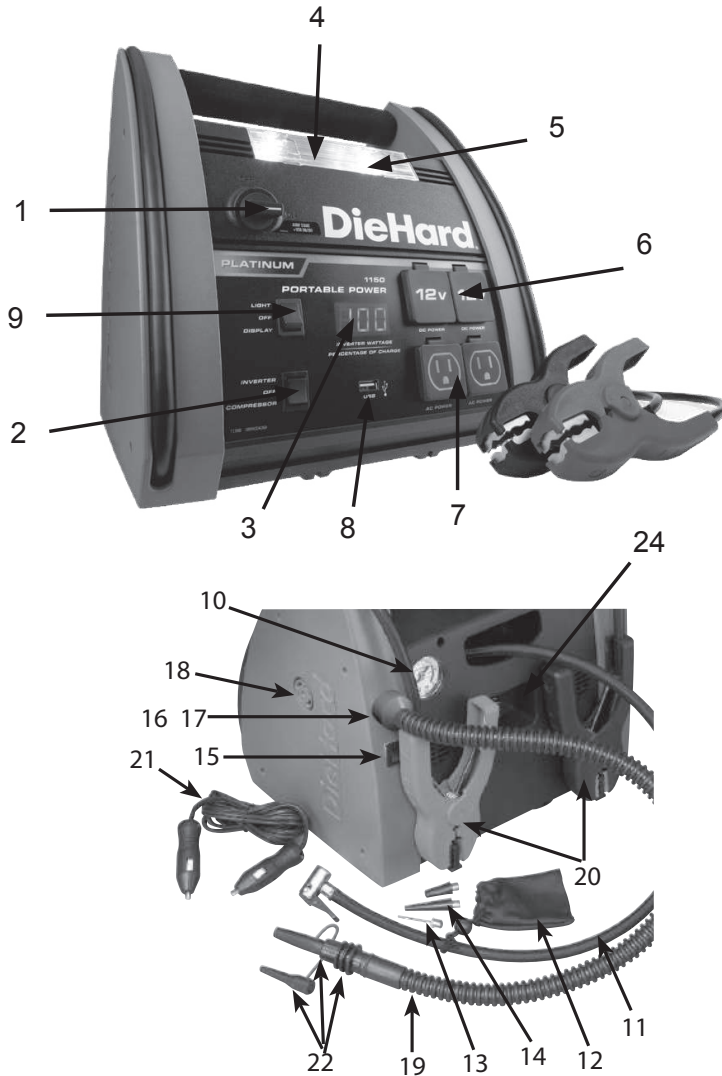

1. Jump Start On/Off switch
2. Inverter/Compressor switch
3. Digital Display
4. Plastic lens cover
5. Two, light bulbs
6. Two, 12V DC power outlets
7. Two, 110V AC household power outlets.
8. USB port
9. Power Switch (Light/Display)
10. Air compressor gauge
11. Air compressor hose
12. Air compressor accessory bag
13. Air compressor ball inflation adapter
14. Two, air compressor miscellaneous inflation adapters
15. ON/OFF inflator/deflator switch
16. High-flow inflator port
17. Inflator/deflator hose end adapter
18. High-flow deflator port
19. Inflator/deflator hose
20. Two cables with clamps
21. Male-to-male accessory 12V charging connector
22. Three inflator/deflator hose device adapters.
23. Wall Charger (not shown)
24. Charger Port
25. Replaceable Battery (not shown)

7. CHARGING THE INTERNAL BATTERY OF THE JUMP STARTER

IMPORTANT: CHARGE IMMEDIATELY AFTER PURCHASE, AFTER EACH USE AND EVERY 30 DAYS TO KEEP THE JUMP STARTER INTERNAL BATTERY FULLY CHARGED.

- 7.1** To check the internal battery's charge status, toggle the Light/Display switch to the DISPLAY position. The Digital Display will show the battery's percent of charge. Charge the internal battery if the display shows it is under 100%

NOTE: Internal battery's percent of charge is most accurate when the jump starter has been disconnected from all devices and charging sources for a few hours.

7.2 Charging the Internal Battery using the Included Wall Charger.

1. To charge, plug the included wall charger into the charger port on the back of the jump starter.
2. Plug the wall charger into a 120V AC electrical wall outlet.
3. While the jump starter is charging, the battery's percent of charge will be displayed. When the internal battery is fully charged, the display will show 100. Complete charging may take up to 72 hours. The jump starter is then ready to use.
4. The charger will automatically go into maintain mode and maintain the battery at full charge without damaging it.
5. Charge the jump starter as soon as possible after use.

IMPORTANT

Do not use the jump starter while charging the internal battery.

You may also charge the internal battery while driving, using the male-to-male charger cable. Insert one end of the accessory cable into the 12V DC power outlet and the other end into the vehicle's accessory outlet (lighter socket). Completely disconnect the charger cable when the engine is not running.

IMPORTANT

Using this method to charge the battery overrides the maintain mode and the battery can be overcharged. Monitor the progress of the battery and when it reaches a full (100%) charge, disconnect the charger. Do not leave the battery unattended or it could explode causing property damage or personal injury.

8. OPERATING INSTRUCTIONS

8.1 Digital Display Functions

To check the jump starter internal battery's status, push the Display Button. The display will show the charge percent of charge of the internal battery.

When connected to the vehicle with the Jump Start On/Off switch in the OFF position, the display shows the vehicle's battery voltage. When connected and in the ON position, the display shows the equalized voltage between the vehicle's battery and internal battery.

When the inverter is turned on and being used, the display will show the total wattage used by the device being powered by the inverter.

8.2 Jump Starting a Vehicle Engine

IMPORTANT

Do not use the jump starter while charging the internal battery.

1. Turn the vehicle's ignition OFF before making cable connections.
2. Connect the jump starter to the battery following the precautions listed in section 3.



Risk of Explosion.

If you have connected the clips backwards, an audio alarm will sound. DO NOT turn the On/Off switch to the ON position. This could cause serious damage to the jump starter or the vehicle. Reverse the connections and the audio alarm will stop.

3. Crank the engine. If the engine does not start within 5-8 seconds, stop cranking and wait at least 1 minute before attempting to start the vehicle again. (This permits the battery to cool down.)

4. After the engine starts, disconnect the black clip (-) and then the red clip (+) in that order.
5. Recharge the jump starter as soon as possible after use.



Risk of Explosion.

To prevent sparking, NEVER allow the clips to touch together or to contact the same piece of metal. Never attempt to jump start a frozen battery.

8.3 Powering a 12V DC Device:

The jump starter is a power source for all 12V DC accessories that are equipped with a 12V accessory plug. Use it for power outages and fishing or camping trips. Estimated usage time is listed in the chart below.

Make sure the device to be powered is OFF before inserting the 12V DC accessory plug into the 12V DC accessory outlet.

1. Ensure that the battery clips are securely clipped on the storage holders.
2. Open the protective cover of the DC power outlet on the front of the jump starter.
3. Plug the 12V DC device into the DC power outlet, and turn the 12V DC device on (if required).
4. If the 12V DC device draws more than 15A or has a short circuit, the internal circuit breaker of the jump starter will trip and disconnect the power to the device. Disconnect the 12V DC device. The breaker will automatically reset after an overload occurs.

The DC power outlet is wired directly to the internal battery. Extended operation of a 12V DC device may result in excessive battery drain. Recharge immediately after unplugging the 12V DC device.

Appliance Type	Estimated Wattage	Estimated Usage Time
Cell Phone	4 watts	66 hours
Fluorescent Light	4 watts	66 hours
Radio, Fan	9 watts	29.3 hours
Depth Finder	9 watts	29.3 hours
Camcorder, VCR	15 watts	17.6 hours
Electrical Tool	24 watts	11 hours
Electrical Cooler	48 watts	5.5 hours
Car Vacuum, Air Compressor	80 watts	3.3 hours

NOTE: Estimated run-times. Actual time may vary. Times are based on the internal battery being fully charged and in good condition.

8.4 Using the USB Port

The USB port provides up to 500mA at 5V DC.

NOTE: When using the USB port, the clips on the jump starter are live and will produce arcing or sparking if they come in contact with each other. To prevent accidental arcing, always keep the clips on the storage holders when not using it to jump start a vehicle.

1. Ensure that the battery clips are securely clipped on the storage holders.
2. Plug the device into the USB port on the front panel.

3. Turn the Jump Starter On/Off switch to the ON position.
4. Turn the USB device on.
5. Reverse these steps when finished using the USB port.
6. Charge the jump starter as soon as possible after using the USB port.

8.5 Using the Built-In Light

1. Position the jump starter on a flat, stable surface near the intended work area.
2. Ensure the battery clips are securely clipped on the storage holders.
3. Press the Light Switch to the ON position.
4. The jump starter light will turn on and illuminate your work area.
5. Press the Light Switch to the OFF position.
6. Charge the jump starter as soon as possible after using the built-in light.

8.6 Using the Air Compressor



Risk of explosion.

Read the instructions of the product being inflated before using the compressor. Avoid over inflation, do not exceed the manufacturer's recommended pressures. Do not leave the air compressor unattended during use.

1. Ensure that the battery clips are securely on the storage holders.
2. Remove the air compressor hose from the storage compartment in the back of the jump starter. Install adapters as necessary.
3. Attach the air compressor hose to the product or accessory to be inflated by flipping down the lever.
4. Place the Inverter/Compressor Switch in the COMPRESSOR position and inflate the product.
5. When the product is inflated to the proper air pressure (using the air compressor gauge) place the Inverter/Compressor Switch in the OFF position and remove the hose.
6. Do not run for more than 10 minutes maximum at a time. Allow the jump starter to cool down for 10 minutes before using again.

NOTE: To prevent overheating, the compressor has built-in thermal protection that will turn the compressor off before it overheats. If the compressor shuts off, wait a few minutes and it will automatically restart when the compressor cools.

NOTE: The air compressor is rated for 150 PSI.

Estimated Time for Inflating

Vehicle Tires 13" to 16"	6 to 24 minutes
Bike Tire	1 to 3 minutes
Sports Balls	30 seconds

These times are approximate, use the air compressor gauge to ensure the proper pressure has been reached. Do not over inflate.

8.7 Using the Inflator

⚠ WARNING



Risk of explosion.

Read instructions of the product being inflated before using the inflator. Avoid over inflation, do not exceed the manufacturer's recommended pressures. Do not leave the inflator unattended during use.

1. Ensure that the battery clips are securely on the storage holders.
2. Attach the corrugated hose with end adapter to the high-flow inflator port located near the inflator ON/OFF switch on the back of the jump starter.
3. The main accessory adapter attached to the corrugated hose accommodates up to 4 sizes. If another size is needed, an additional adapter can be attached to the end of the main accessory adapter.
4. Insert the adapter into the product to be inflated.
5. Push the Inflator switch to the ON position and inflate the product.
6. When product is inflated to the desired level, push the Inflator switch to the OFF position and remove the adapter.

Estimated Time for Inflating

24" Beach Ball	1 to 3 minutes
Pool Raft	4 to 6 minutes
Queen-size Air Mattress	4 to 8 minutes
2 Person Boat	8 to 10 minutes

Times are estimates and will vary depending on size and product features.

8.8 Using the Deflator

1. Ensure that the battery clips are securely on the storage holders.
2. Attach the corrugated hose with the end adapter to the high-flow deflator port which is located on the side of the jump starter.
3. The main accessory adapter attached to the corrugated hose accommodates up to 4 sizes. If another size is needed, an additional adapter can be attached to the end of the main accessory adapter.
4. Insert the adapter into the item to be deflated.
5. Push the Inflator switch to the ON position and deflate the item.
6. When the product is deflated to the desired level, push the Inflator switch to the OFF position and remove the adapter.

8.9 Before Using the Inverter

Important Safety Instructions:

1. Keep the jump starter well ventilated in order to properly disperse heat generated while it is in use. Make sure there are several inches of clearance around the top and sides, and do not block the vents on the back of the jump starter.
2. Make sure the jump starter is not close to any potential source of flammable fumes, gases or clothing.
3. Keep the jump starter dry.
4. DO NOT allow the jump starter to come into contact with rain or moisture.

5. DO NOT operate the jump starter if you, the jump starter, the device being operated or any other surfaces that may come in contact with any power source are wet. Water and many other liquids can conduct electricity, which may lead to serious injury or death.
6. Do not place the jump starter on or near heating vents, radiators or other sources of heat.
7. Do not place the jump starter in direct sunlight. The ideal air temperature for operation is between 50° and 80°F.
8. Do not use the inverter near an open engine compartment where fumes or gases may accumulate.
9. Do not modify the AC receptacles in any way.

8.10 Using the Inverter

It is important to know the continuous wattage of the device you plan to use with the inverter. The jump starter must be used with devices drawing 400 watts or less. If the wattage is not marked on the device, use only devices that draw less than 4 Amps of AC current.

Devices like TVs, fans or electric motors require additional power to start (commonly known as the “starting” or “peak power”). The jump starter can supply a momentary surge in wattage; however even devices rated less than the maximum 400 watts can exceed the inverter's surge capability and cause an automatic overload shutdown.

Do not use the inverter with a product that draws a higher wattage than the inverter can provide, as this may cause damage to the inverter and the product.

Make sure the device you are using is compatible with a modified sine wave inverter.

CAUTION

Always run a test to establish whether the inverter will operate a particular piece of equipment or device.

In the event of a power overload, the inverter is designed to automatically shut down. This safety feature prevents damaging the inverter while testing devices and equipment within the 400-watt range.

If powering more than one device, start one device at a time to avoid a power surge and/or inverter overload. The surge load of each device should not exceed the inverter's Continuous Operation wattage rate.

If you are using the power inverter to operate a battery charger, monitor the temperature of the battery charger for about 10 minutes. If the battery charger becomes abnormally warm, disconnect it from the inverter immediately.

You can use an extension cord from the inverter to the device without significantly decreasing the power being generated by the inverter. For best operating results, the extension cord should be no longer than 50 feet.

IMPORTANT

This inverter uses a nonsinusoidal waveform. Therefore, we do not recommend you use it to power the following devices:

1. Switch Mode Power Supplies;
2. Linear Power Supplies;
3. Class 2 Transformers;
4. Line Filter Capacitors;
5. Shaded Pole Motors;
6. Fan Motors;
7. Microwave Ovens;

8. Fluorescent and High Intensity Lamps (with a Ballast); and
9. Transformerless Battery Chargers.

Doing so, may cause the device to run warmer or overheat.

8.11 Powering a 120V AC Device

To operate a 120V AC device:

1. Ensure that the battery clips are securely on the storage holders.
2. Open the protective cover of the AC power outlet on the front panel of the jump starter.
3. Make sure the 120V AC device to be operated is turned OFF.
4. Plug the 120V AC device into the AC power outlet, and turn the Inverter/ Compressor Switch to the INVERTER position.
5. Turn the device on.
6. If the device does not operate properly when first connected to the inverter, push the inverter rocker switch ON, OFF, and ON again in quick succession. If this procedure is not successful, it is likely that the inverter does not have the required capacity to operate the device intended.
7. Charge the jump starter as soon as possible after each use.



Risk of electric shock.

Incorrect operation of your inverter may result in damage and personal injury. The inverter output is 120V AC and can shock or electrocute the same as any ordinary household AC wall outlet.

120V AC Electrical Device Example Run-Time Chart

Appliance Type	Estimated Power	Estimated Time*
Spotlights, Sump Pumps, DVD Players	100 Watts	1.5 Hours
Faxes, TVs, Small Power Tools	150 Watts	1.25 Hours
Computer Printer, Medium Power Tools, Blenders	200 Watts	55 Minutes

NOTE: These are estimated run-times, actual time may vary. Times are based on the internal battery being new, fully charged and operated at room temperature

NOTE: The maximum continuous load is 400 watts. Do not use the inverter with a product that draws more than 400 watts, as this may cause damage to the inverter and the product.

9. MAINTENANCE INSTRUCTIONS

- 9.1 After use and before performing maintenance, unplug and disconnect the jump starter (see sections 3 and 4).
- 9.2 Use a dry cloth to wipe all battery corrosion and other dirt or oil from the battery clips, cords, and the jump starter case.
- 9.3 Ensure that all of the jump starter components are in place and in good working condition, for example, the plastic boots on the battery clips.
- 9.4 Servicing does not require opening the unit, as there are no user-serviceable parts.
- 9.5 All other servicing should be performed by qualified service personal.

10. MOVING AND STORAGE INSTRUCTIONS

- 10.1** Store the jump starter in an upright position.
- 10.2** Store inside, in a cool, dry place.
- 10.3** Do not store the clips on the handle, clipped together, on or around metal, or clipped to cables. The clips on the jump starter are live and will produce arcing or sparking if they come in contact with each other. To prevent accidental arcing, always keep the clips on the storage holders when not using it to jump start a vehicle.
- 10.4** If the jump starter is moved around the shop or transported to another location, take care to avoid/prevent damage to the cords, clips and jump starter. Failure to do so could result in personal injury or property damage.

IMPORTANT

Do not use and/or store the jump starter in or on any area or surface where damage could occur if the internal battery should unexpectedly leak acid.

10.5 IMPORTANT:

- **CHARGE IMMEDIATELY AFTER PURCHASE**
- **KEEP FULLY CHARGED**

Charge the jump starter internal battery immediately after purchase, after every use and every 30 days.

All batteries are affected by temperature. The ideal storage temperature is at 70 degrees Fahrenheit. The internal battery will gradually self-discharge (lose power) over time, especially in warm environments. Leaving the battery in a discharged state may result in permanent battery damage. To ensure satisfactory performance and avoid permanent damage, charge the internal battery every month.

11. TROUBLESHOOTING

PROBLEM	POSSIBLE CAUSE	REASON/SOLUTION
The jump starter won't jump start my car.	Jump Start/USB Switch is not turned ON.	Turn ON the Jump Start/USB Switch.
	Clips are not making a good connection to the battery.	Check for poor connection to battery and frame. Make sure connection points are clean. Rock the clips back and forth for a better connection.
	The jump starter battery is not charged.	Check the battery charge status by pressing the button on the front of the jump starter. See DIGITAL DISPLAY FUNCTIONS section of this manual.
	The vehicle's battery is defective.	Have the battery checked.

PROBLEM	POSSIBLE CAUSE	REASON/SOLUTION
The jump starter won't power my 12V device.	<p>The 12V device is not turned on.</p> <p>The jump starter battery is not charged.</p> <p>The 12V device draws more than 15A or has a short circuit</p>	<p>Turn on the 12V device.</p> <p>Check the battery charge status by pressing the button on the front of the jump starter. See DIGITAL DISPLAY FUNCTIONS section of this manual.</p> <p>Disconnect the 12V device. The internal breaker will automatically reset after a minute or two. Try the 12V device again. If it happens again, replace the 12V device.</p>
The battery in the jump starter won't hold a charge.	The battery is bad (will not accept a charge).	Have the battery checked.
The jump starter alarm is on.	Connections are reversed.	Disconnect the jump starter and reverse the clips.

12. SPECIFICATIONS

Internal Battery Type	Maintenance-free AGM Lead-acid
Nominal Voltage	12v DC
Capacity	22 Ah
DC Power Outlet (Max. Continuous Load)	15A (both outlets combined)
Built-in Work Light (Non-replaceable)	Two, 5w/12v DC (Base type BA9S)
Jumper Cables	4-gauge AWG, 24 Inches
Dimensions (H x W x D)	12 H x 11.5 x 10.5 Inches
Product Weight	24.5 lbs.

AC Power Specifications

Maximum Continuous Power	400 Watts
Surge Capacity (Peak Power)	800 Watts
No Load Current Draw	<0.3 Amps
Wave Form	Modified Sine Wave
Input Voltage Range	10.5 - 15.5V DC
AC Outlets	Two, 120V AC 3-Prong NEMA 5-15

13. REPLACEMENT PARTS/ACCESSORIES

Air Compressor Accessory Kit (3 Hose Adaptors) -----00-99-000599

Inflator Accessory Kit: (Inflator / Deflator Hose, Unit End and 3 Hose Adaptors)
-----00-99-000598

Male-to-Male Accessory 12V Charging Connector ----- 94500109