

DIXIE CHOPPER

The World's Fastest Lawn Mower

Serial Numbers
SE3000001
and Higher

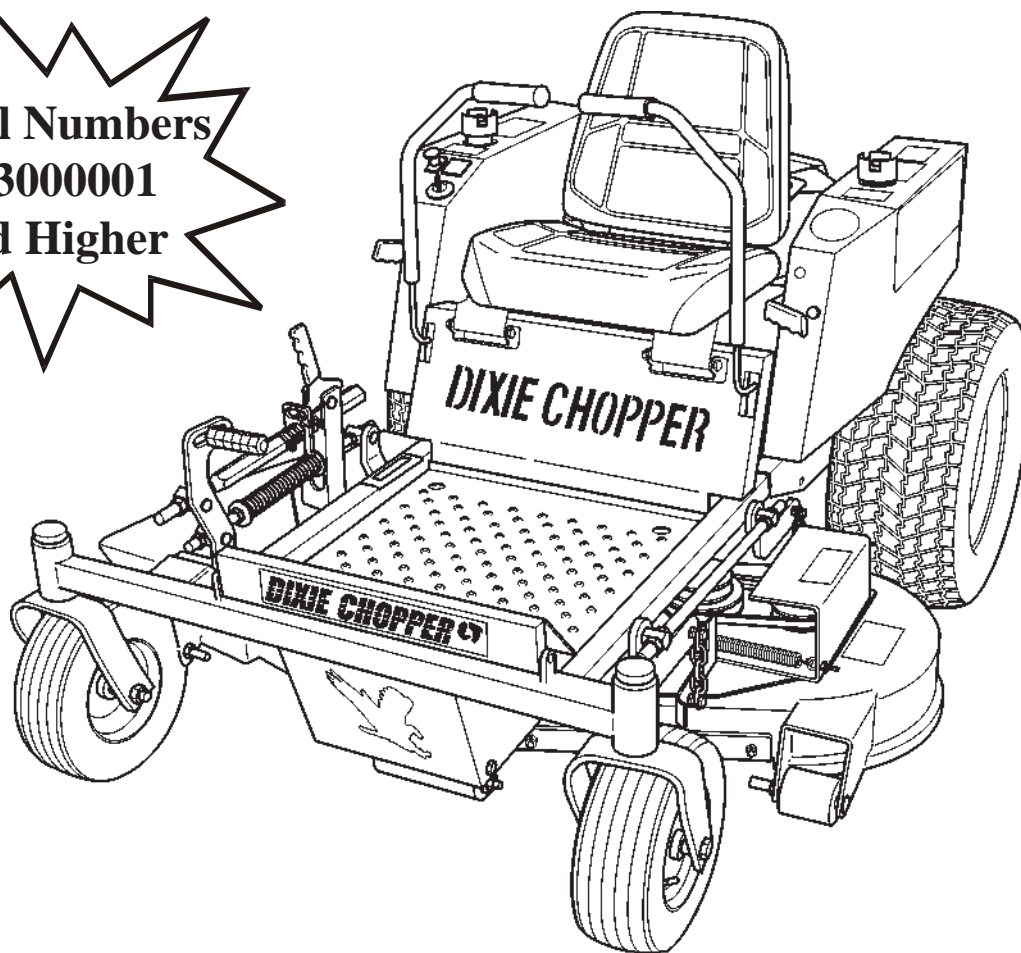

Model # _____ Engine Model # _____

Serial # _____ Engine Serial # _____

Date Purchased _____ Engine Spec. # _____

SILVER EAGLE OPERATION MANUAL

February, 2003

DIXIE CHOPPER

Congratulations on your purchase of a **DIXIE CHOPPER** lawn mower. We believe you have exercised excellent judgement and are most appreciative of your patronage.

We recommend that you read this entire manual before operating this unit. Time spent in becoming fully acquainted with its operating procedures will add a longer and more satisfactory life to your **DIXIE CHOPPER**.

To obtain the latest information on your Dixie Chopper lawn mower and receive the highest quality service, please call or visit your nearest authorized Dixie Chopper dealer.

AUTHORIZED DEALER

Dixie Chopper reserves the right to make changes or add improvements to its products at any time without incurring any obligation to make such changes to products previously manufactured. Neither Dixie Chopper nor its dealers accept responsibility for variations which may be evident in the actual specifications of its products and the statements and descriptions contained in this publication.



CONTENTS

Introduction	4
Warranty	4
General Safety Precautions	6
Special Features, Capabilities, and Specifications	8
Using This Manual	10
Controls and Indicators	11
Start-Up and Operation of Mower	13
Basic Mower Adjustments, Maintenance, and Repairs	17
Mower Cleaning and Off-Season Storage	20
Operator Controlled Discharge Chute	22
Routine Maintenance	23
Lubrication Points	24



Introduction

Prior to operating the Dixie Chopper lawn mower, you should be trained in its proper use and warned of its dangers before operating, adjusting, or servicing it. Read and understand this entire manual.

DANGER

This symbol, if used, warns of immediate hazards which will result in severe personal injury or death.

WARNING

This symbol refers to a hazard or unsafe practice which can result in severe personal injury or death.

CAUTION

This symbol refers to a hazard or unsafe practice which can result in severe personal injury or product or property damage.

- Familiarize yourself with the controls and know how to stop the mower quickly.
- Inspect your work area carefully. Remove debris from the turf area to be cut.
- Avoid contact with moving parts. Keep away from whirling blades. Keep feet and hands away from underneath mower deck.
- Never direct discharge of material toward bystanders nor allow anyone near the machine while in operation.
- This machine is not meant for highway or street use. It is not a recreational vehicle and you should never carry passengers.
- Never tamper with safety devices or guards. If a guard or safety device is damaged or removed, replace before operating mower.
- Handle gasoline carefully. Never add fuel to tank while the engine is running or hot.

WARRANTY

THERE ARE NO UNDERSTANDINGS, AGREEMENTS, REPRESENTATIONS, OR WARRANTIES EXPRESSED OR IMPLIED (INCLUDING BUT NOT LIMITED TO ANY REGARDING THE MERCHANTABILITY OR FITNESS FOR A PARTICULAR PURPOSE), NOT SPECIFIED HEREIN, REGARDING THE EQUIPMENT WHICH IS THE SUBJECT OF THIS WARRANTY.

Owner/Operator Knowledge Responsibility

As a condition of the Dixie Chopper warranty, the owner and operator(s) are fully responsible for having read, and reasonably understanding the proper operation and care of the Dixie Chopper unit Before Attempting to Operate the Machine.

Through the terms and conditions contained herein, Magic Circle Corporation (Dixie Chopper) warrants that it will adjust, repair, or replace, any factory original part used in the manufacturing of a Dixie Chopper complete unit, found to be defective in material or workmanship.

Silver Eagle Complete Unit

The warranty period is limited to **one year** from the date of retail purchase on behalf of the original owner of a Dixie Chopper complete unit. This warranty will provide the cost of repair or replacement (at the discretion of Dixie Chopper) of the defective part, including labor. This warranty applies only to original retail purchaser of a Dixie Chopper complete unit for personal use, and not used for income producing purposes.

Silver Eagle Drive Train

The hydrostatic drive components (pumps and wheel motors) of the Dixie Chopper complete unit will be warranted for **two years** from the retail purchase date on behalf of the original owner against defects in materials or workmanship. Labor required to repair or replace components of the hydrostatic drive system will be covered by Dixie Chopper for the 1st year, and at the unit owners expense during the 2nd year from the original purchase date.

Silver Eagle Deck Spindle Assembly

Parts and labor for the replacement of the complete deck spindle assembly (deck hub, deck spindle bearings, deck hub spacer, and blade spindle shaft), of the Dixie Chopper complete unit will be warranted for **three years** from the retail purchase date on behalf of the original owner against defects in materials or workmanship.

Battery

Dixie Chopper original equipment batteries are warranted against OEM factory defects in materials or workmanship ("discharged only" and "abuse" are not covered). If battery failure occurs within 6 months of unit purchase date, battery will be replaced at no charge. Battery failures occurring beyond 6 months but less than 1 year from date of unit purchase will be replaced at 50% of the cost of the standard replacement battery.



WARRANTY (continued)

Silver Eagle Front Forks and Stainless Steel Body Parts

Dixie Chopper will provide to the original purchaser beyond the initial one year warranty. Any front fork due to breakage, or any stainless steel body part due to rust, for the useful life period of the machine. This additional **“lifetime warranty”** covers stated parts **ONLY....NO LABOR.**

Engine

The engine warranty is provided by the engine manufacturer. Please refer to the engine manufacturer warranty statement included with the ownership materials provided with the unit. Dixie Chopper is not authorized to handle warranty adjustments on engines. Engine warranty claims must be filed with the appropriate engine manufacturer for necessary warranty repairs. In general, engines used on Dixie Chopper units are warranted by the respective engine manufacturer for a period of **two years** from the retail purchase date on behalf of the original owner.

Tires and Belts

Tires and belts are considered to be consumable-wear items, and are therefore, warranted for a period of 90 days against materials or workmanship defects, not for wear or abuse.

Transportation for Warranty Repairs

A Dixie Chopper complete unit (including any defective parts) requiring warranty repair, must be returned to an authorized Dixie Chopper Service Dealer within the warranty period. The expense of transporting the unit to and from the dealer for warranty work will be the responsibility of the unit owner.

Limitation of Warranty

The product registration card must be submitted to Dixie Chopper within 3 days of the original retail purchase date to enable validation of the warranty period provided. Proof of purchase may be required of the unit owner to substantiate any warranty claim.

All warranty work must be performed by an authorized Dixie Chopper Servicing Dealer **ONLY.**

This warranty covers only Dixie Chopper complete units, which are properly serviced, maintained, and operated under conditions considered normal for turf equipment.

Expressly Not Covered

- a) Replacement of service items such as oil, lubricants, spark plugs, belts, rubber hoses, or other items subject to normal service replacement.
- b) Maintenance services such as cleaning, lubrication, oil change, blade sharpening, etc.
- c) Damage, defects or deterioration due to normal use, wear, or exposure to elements.
- d) Damage or defects resulting from misuse, neglect, alteration, accident or negligence.
- e) Use of fuels, oils, or lubricants other than as specified.
- f) Damage or defects resulting from repairs by person(s) other than an authorized Dixie Chopper service dealer or installation of parts other than genuine Dixie Chopper parts or parts recommended by Dixie Chopper.
- g) Repairs, alterations or installations of accessories, which have an adverse affect on the operation, performance, or durability of the Dixie Chopper complete unit.
- h) Repair or replacements resulting from operations of Dixie Chopper equipment that has been modified, altered, or affected with respect to the intended use of the product.
- i) Repair or replacement as a result of Dixie Chopper equipment operated in a manner which is not in accord with the instructions as specified in the operator's manual or other instructions provided by Dixie Chopper.

Dixie Chopper Is Not Responsible For...(nor limited to the following)

- j) Travel time, overtime, after-hours time or other extraordinary repair charges or charge relating to repairs or replacements outside of normal business hours at the place of business of the authorized Dixie Chopper service dealer.
- k) Loss, cost or expense relating to transportation of Dixie Chopper equipment from the location of owner or location where used by owner to or from any authorized Dixie Chopper service dealer.
- l) Expenses relating to gasoline, oil, or lubricants.
- m) Rental of like or similar equipment during the time of any warranty, or replacement work.
- n) Any claims for lost revenue, lost profit or additional cost or expense incurred as a result of a claim of breach of warranty.
- o) Loss or damage to person or property other than that covered by the terms of this warranty.
- p) Any telephone, telegram, travel charges, or attorney's fees.

Disclaimer

Any and all statements or representations made by seller of this equipment, including those set forth in any sales literature or made orally by any sales representative, are superceded by the terms of this warranty. There are no representations or warranties, which have been authorized and provided to the buyer of Dixie Chopper equipment, other than as set forth in this warranty. Any affirmation of fact or promise made by Dixie Chopper or any of its representatives to the buyer which relates to the goods that are the subject of this warranty shall not be regarded as part of the basis of the bargain and shall not be deemed to create any express warranty that such goods shall conform to the affirmation or promise.



General Safety Precautions

1. Know the location and function of the controls and how to operate them. Know how to stop quickly. **READ AND UNDERSTAND THIS OPERATION MANUAL AND THE INSTRUCTIONS FURNISHED WITH ATTACHMENTS BEFORE ATTEMPTING TO OPERATE THIS MOWER.**
2. Do not allow children to operate machine. Do not allow adults to operate machine without proper instruction.
3. Do not carry passengers. **Do not mow when children, pets, or others are present.** The operator is responsible for the safety of others within the vicinity of the operation of this mower.
4. Keep hands, feet, and clothing away from rotating blades or other rotating parts while engine is running.
5. Clear the work area of objects (wire, rocks, and debris of any kind) that can be picked up and thrown by the mower, and possibly damage the equipment or cause personal injury to the operator or bystanders.
6. Disengage all attachment clutches, set parking brake, and place steering speed control levers into neutral lock (open) position before attempting to start engine.
7. Disengage power to attachments, stop engine, and remove ignition key before leaving the operator position or leaving machine unattended.
8. Do not attempt to adjust or repair the mower deck, the drive system, the mower blades, or any moving parts of the vehicle while the engine is running. You must disengage power to attachments, disengage PTO, set parking brake, set steering control levers to neutral lock, **shut off the engine**, and remove key before making any repairs or adjustments or attempting any of the following tasks:
 - a. Deck pitch adjustment
 - b. Unclogging the chute
 - c. Checking blade mounting bolts for proper tightness at frequent intervals
 - d. Refueling
9. Failure to comply can result in personal injury or death.
9. Disengage power to attachments when transporting or not in use.
10. Attempting to use this mower on slopes exceeding 15 degrees is not recommended. Reduce speed and exercise extreme caution on slopes to prevent tipping or loss of control. Be especially cautious and **slow down** when changing directions on slopes. **DO NOT** mow slopes when grass is wet.
11. Stay alert for holes, rocks, and roots in the terrain which can cause the vehicle to upset. Keep away from dropoffs.
12. When mowing uphill, avoid sudden stops to prevent tipping over. When mowing downhill, loss of traction and/or braking ability can occur. To compensate, slightly increase ground speed and make shallow turns gradually, until tighter control is regained.
13. Use care when pulling loads or using heavy equipment.
 - a. Use only approved drawbar hitch points.
 - b. Limit loads to those you can safely control.
 - c. Do not turn sharply. Use care when backing.
 - d. Use counterweights as advised in the Owner's Manual.
14. Watch out for traffic when near to or crossing roads, and obey traffic laws. Disengage blades and wait for them to stop before crossing gravel roads.
15. When using any attachments, never direct discharge of materials toward bystanders, nor allow anyone near the vehicle while it is in operation.
16. Keep all nuts, bolts, and screws tight to be sure equipment is in safe working condition.
17. Allow engine to cool before storing in any enclosure.
18. Never attempt to operate mower while under the influence of alcohol or drugs.



General Safety Precautions (continued)

19. Handle gasoline with care - it is highly flammable.
Follow these guidelines:
 - a. Use approved gasoline container.
 - b. Place container out of reach of children.
 - c. Use gasoline only as a fuel, never as a cleaner.
 - d. Never remove cap to add gasoline to a running or hot engine, or to an engine that has not been allowed to cool for several minutes after running.
 - e. Never fill fuel tank indoors.
 - f. Wipe up spilled gasoline.
 - g. Positively NO SMOKING.
 - h. Never store equipment with gasoline in the tank inside a building where fumes may reach an open flame or spark.
 - i. Always have a fire extinguisher present when using gasoline or other flammable substance.
20. Keep vehicle and attachments in good operating condition and keep safety devices, such as guards, shields, and covers, in place and working.
21. Do not operate the mower or attachments if any guards are missing or not functioning properly.
22. Stop the mower and attachments, secure the mower, and inspect for damage after striking a foreign object. Repair any damage before restarting and operating the equipment.
23. Do not change engine governor settings or overspeed the engine.
24. Disengage power to mower before backing up. No mower is designed to mow in reverse, nor can it be safely operated in reverse. Dixie Chopper's Zero Turning Radius eliminates the need for backing up. Simply turn the mower around within its own dimension and proceed forward.
25. Do not mow with mower blades that are out of balance or have eroded airlifts and/or split ends.
26. Use personal protective equipment when operating mower or performing maintenance, such as (but not limited to) protection for eyes, ears, feet, and head. **Do not** operate or service the mower when barefoot or wearing open-toed sandals.
27. Use caution when handling mower blades during replacement or maintenance. Wear appropriate protective gloves and clothing and cover the sharp cutting edges of the blades. Failure to comply can result in personal injury.
28. Operate mower only in daylight or good artificial light.
29. If at all possible, do not operate mower when grass is wet.
30. Do not make sudden turns, stops, starts, reversals, or any abrupt maneuvers, especially when negotiating slopes. The steering speed control arms are very responsive to slight movement. Rapid, rough, or jerky manipulation of the steering speed control arms can result in damage to equipment and personal injury.
31. Do not run the engine in an enclosure without adequate ventilation to the outside. Exhaust fumes contain carbon monoxide which is odorless and deadly poisonous to humans. Failure to comply can result in personal injury or death.
32. Do not work underneath the mower unless it is supported safely by jack stands with a safe working load capacity of 1/2 ton or more, a hoist, or blocks. Failure to comply can result in personal injury or death.
33. Disconnect the spark plug wires and place the wires where they cannot contact spark plugs when setting up, adjusting, doing repairs on, or transporting your mower. Mower can accidentally start if spark plug wires are connected. Failure to comply can result in personal injury or death.
34. Do not touch hot parts of the mower. Failure to comply can result in personal injury.
35. Give complete and undivided attention to the job at hand.
36. Obey all safety decals.



Special Features, Capabilities, and Specifications

Major Features

At Dixie Chopper, we believe that every machine should pack the maximum amount of performance. We also believe if you listen to your customers, they will tell you what they want; and we have been listening to our customers for years!

That is why we have introduced the Silver Eagle Series LT2000-50 to the market. The Silver Eagle is equipped with many of the features found on our proven line of mowers; the same features requested by our loyal customers. A few of those features include:

- A low center of gravity to provide stability.
- A hinged floor pan to provide excellent access to critical areas.
- Exceptional fuel capacity so you can run longer between fill-ups.
- Stainless steel body panels to let everyone know you own a Dixie Chopper!

You spoke, we listened!

Velvet Touch Control (VTC)

The "VTC" system "sets the gold standard in Zero Turning Radius mower performance," according to *Art Evans, Dixie Chopper President*. "For years, we've been searching for ways to make the drive systems run cooler and live longer. Of course, the amount of heat generated by the hydro system has a monumental influence on the overall life of the hydraulic system components. We have proven, during our testing, that this new "VTC" oil that we have developed will add an extraordinary amount of life to the **Dixie Chopper** hydro drive system," Evans says. The **Dixie Chopper "Velvet Touch Control"** system is a compilation of several factors that include proprietary modifications to the **Hydro-Gear** hydraulic pumps as well as the new oil developed by the company. But according to Evans, his new oil is

the key that makes the whole system work. "Not only will this benefit current and future **Dixie Chopper** owners, the "VTC" oil will improve the performance and add longevity to any other brand of zero-turn mower they might currently own. This oil makes that much difference. You have to experience the feel of this oil in a machine, and you won't believe the feeling. It operates so much smoother and easier that we were able to remove the neutral springs from our machine so that the steering levers offer a minimum amount of resistance, **greatly reducing the fatigue factor for the operator**. You won't want to go back to your other z-machines with shock dampeners after you operate a Dixie Chopper with the "VTC" system. Your other machine will be more work than you want," Evans says with a grin.

Productivity Chart

The following is an "Acres Per Hour" productivity chart for the Silver Eagle LT2000-50 model Dixie Chopper mower. Efficiency ratings of 100% and 80% are shown. Eighty percent reflects actual mowing conditions, considering turns and overlapping.

MPH	100%	80%
4.0	2.02	1.67
4.5	2.27	1.87
5.0	2.52	2.08
5.5	2.78	2.30
6.0	3.03	2.50
6.5	3.28	2.70
7.0	3.53	2.92

$$100\% \frac{\text{MPH} \times \text{cut width}}{99} = \text{Acres per hour}$$

$$80\% \frac{\text{MPH} \times \text{cut width}}{120} = \text{Acres per hour}$$



Special Features, Capabilities, and Specifications (continued)

Specifications

- Engine**
- Kohler, CV20S, vertical shaft, V-twin, four cycle, air-cooled engine
 - 20 Hp total output at 3750 RPM
 - 38.0 in³ displacement
 - Electric start, gear-driven oil pump for full pressure lubrication
 - Engine-mounted, replaceable 25 micron Kohler oil filter
 - Pulse fuel pump (more efficient and less moving parts than a mechanical fuel pump)
 - Kohler muffler to meet noise requirements

- Electrical**
- 12 volt, 66 plate, 295 cold cranking amp, maintenance-free battery
 - 15 amp alternator/starter with regulator-rectifier
 - Electric start
 - ALL NEW operator presence controls. Seat switch, clutch switch, parking brake, and steering speed control lever switches all combine to provide a safe environment for operators
 - Hg tilt shut-off switch

- Weight**
- 785 pounds

- Fuel**
- 6.0 US gallons

- Main Frame**
- Welded 2" x 2" frame
 - Stainless steel fenders with cup holder
 - ALL NEW skid-proof, easy clean, flip-up floor pan

- Mower Deck**
- Switch-operated, electric clutch deck engagement
 - 1" diameter spindle shafts with self-tightening spindle assembly

- Keyless spindle extends greasable bearing life by preventing side load
- Welded baffles
- Level pitch while raising or lowering deck
- Deck mounted to rigid frame (does not run on the ground)
- Deck rollers to prevent scalping ground
- Wide open mouth for easy discharge
- Four (4) deck leveling bolts

- Deck Materials**
- Ten (10) gauge shell (.135" thickness)
 - .187" thick reinforcing top plate (bolted, not welded)
 - Total thickness in critical area = .322"
 - One piece cast hubs (bolted, not welded)
 - Split steel spindle pulleys (.1875" thick)

- Cutting Height**
- 1.75" to 5.75" (1.25" with under-slung blades)

- Cut Width** • 50" **Track Length** • 49"

- Overall Width** • 54" **Overall Length** • 75"

- Drive**
- Two (2) Hydrogear BDP-10A pumps, direct belt-driven
 - Two (2) White Hydraulics CE series 14.6 in³ hydraulic motors with automotive style brake
 - Two (2) 40 micron hydraulic filters
 - Two (2) hand-operated forward/reverse steering/braking controls

DIXIE CHOPPER

Special Features, Capabilities, and Specifications (continued)

- 2.25 gallon hydraulic reservoir
 - Exclusive Dixie Chopper special blend VTC oil
- Gauges**
- ALL NEW hourmeter with integrated PTO light and brake light
- Controls**
- ALL NEW foot-operated/spring assist mower deck height adjustment
 - Two (2) hand-operated steering speed control levers
 - Switch-operated electric clutch mower deck engagement
 - Throttle control
 - Choke control
 - Ignition switch
 - Positive lock drum type parking brake
 - Optional, Dealer-Installed Operator Controlled Discharge Chute (OCDC)
- Steering**
- Independent control of drive wheels through steering speed control levers
- Brakes**
- Dynamic braking through steering speed control levers
 - Automotive style parking brake gives positive lock-up of drive wheels when applied
- Speed**
- 0-8 mph forward and reverse
- Tires/
Wheels**
- Rear: 24 x 10.5-12 tubeless Turf-Pro 2-ply rating (6-8 lbs)
 - Front: 13 x 5-6 tubeless 4-ply rating (12-15 lbs)

Using This Manual

The general operation, adjustment, and maintenance procedures contained in this manual are meant for both the beginner and the experienced Dixie Chopper operator. Obviously, operating conditions will vary greatly for each person and their situation, and every individual case cannot be addressed here. With experience, operators should have no trouble developing good operating skills for the safe and effective handling of most conditions.

Unless otherwise stated, the directional references used in this manual, forward, backward, right or left, refer to an operator orientation of being seated on the mower, facing forward.

Illustrations and photographs used in this manual were current at the time of the printing of the manual. However, production changes may have occurred after the time of the purchase of your Dixie Chopper; therefore, your unit may vary slightly from what is depicted in this manual.

Dixie Chopper reserves the right to change, modify, alter, or improve the design of the machine, as deemed necessary by Dixie Chopper, without notification to existing owners or purchasers of the machines. If your machine does not appear to be configured exactly as reflected in this operation manual, or the parts manual, contact your authorized Dixie Chopper dealer for current information and parts.

DIXIE CHOPPER

Controls and Indicators

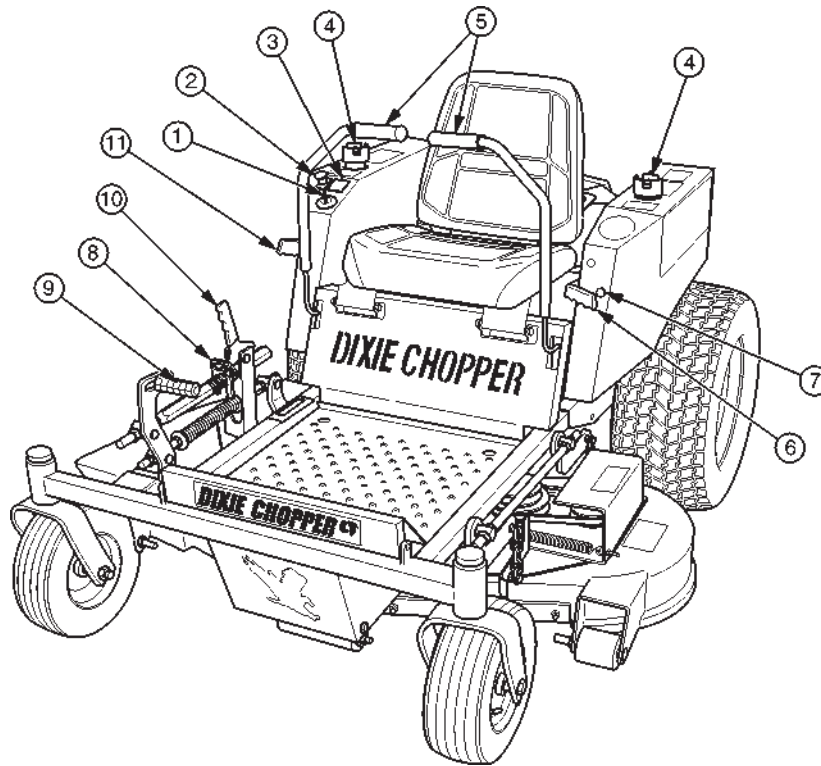

Control/Indicator Name	Control/Indicator Description
1. IGNITION SWITCH	Controls electrical power to the mower. Switch has three positions: OFF; RUN; START. In OFF position, no power flows to the mower electrical components. In RUN position, power flows to all mower electrical components. In START position, electrical power flows to the engine starter.
2. DECK ENGAGING SWITCH (PTO)	Controls operation of the mower deck blades. Pull switch up to engage the mower blades, and push it down to disengage the mower blades.
3. INDICATOR LIGHTS/ HOURS FUNCTION METER	Conveys important information to the operator by four lights that are labeled with icons to indicate (clockwise from upper left): low battery power; low oil pressure; parking brake on; and deck engaging (PTO) switch on. Also, the hours of engine operation is displayed on an LCD.
4. FUEL CAPS	Cover fill openings of the right and left fuel tanks.



Controls and Indicators (continued)

Control/Indicator Name	Control/Indicator Description
5. STEERING SPEED CONTROL LEVERS	Control the speed and direction of the mower. Moving both levers forward causes the mower to move forward and moving both levers backward causes the mower to back up. Moving one lever forward will cause the mower to turn. The farther the levers are moved forward or backward, the faster the mower will move in that direction. The levers may be locked in neutral position by pushing both levers outward left and right to their respective farthest points.
6. PARKING BRAKE LEVER	Applies the brakes to hold the mower in a stationary position. Pull the lever up to set the brakes and push it down to release the brakes.
7. CHOKE CONTROL	Causes a rich fuel/air mixture in the carburetor. Used to start a cold engine and to keep the engine running until it warms up.
8. DECK HEIGHT STOP	A steel plate used to set the mower deck height.
9. DECK FOOT PEDAL	Raises the mower deck when pushed with your foot.
10. DECK LOCK HANDLE	Locks the mower deck in its highest raised position.
11. THROTTLE	Controls engine speed. Moving the throttle all the way down sets the engine speed to maximum. Moving the throttle all the way up sets the engine speed to idle.



Start-Up and Operation of Mower

WARNING Do not run the mower engine in confined areas such as a closed garage. Take care not to inhale exhaust gases as they contain carbon monoxide, which is a colorless, odorless gas that can cause unconsciousness and is potentially lethal. Failure to comply can result in damage to equipment and injury to persons or death to persons.

CAUTION Handle fuel with care. It is highly flammable. Use only approved fuel containers. Never add fuel while the engine is running or hot. Fill fuel tanks outdoors, never indoors. Replace fuel tank cap securely and wipe up all spilled fuel. Failure to comply can result in damage to equipment and injury to persons.

CAUTION Before starting the engine, become familiar with all controls. Read and understand this Operation Manual thoroughly. Always check for proper engine oil level before starting engine. Failure to comply can result in damage to equipment and injury to persons.

To Start The Mower:

NOTE: Mower will **not** start if steering speed control levers are not in the neutral lock position and parking brake is not set.

1. Place steering speed control levers in neutral lock position.
2. Sit in mower seat.
3. Pull parking brake lever all the way up to set parking brake.
4. Set throttle to 1/4-power position.
5. Pull out choke (if engine is cold). Choke control activates a valve that causes a rich fuel/air mixture in the carburetor, which will assist in starting and warming up a cold engine.

NOTE: If the engine fails to start after 6-7 seconds of continuous cranking, turn the key to the OFF position and allow the starter motor to cool.

6. Turn ignition switch to the START position. Release key after engine starts. Key will automatically return to the RUN position.
7. Allow engine to warm up, then slowly push choke button in.

To Mow:

1. Set mowing deck height to desired cut height (if different from factory setting). (Refer to Deck Height Adjustment for detailed instructions.)
2. Push parking brake lever all the way down to release parking brake.
3. Set throttle to **1/4-power** position.
4. Engage mower deck by pulling up on deck engaging switch (PTO).
5. Close steering speed control levers.

NOTE: Always set engine speed at full-throttle when mowing, and maintain a minimum of 3600 RPM and a maximum of 3750 RPM. This engine speed will provide the necessary airflow through the engine cowling to prevent overheating, and will maintain blade speed for a satisfactory quality of cut. If the engine pulls below 3500 RPM when under load, slow down the ground speed and allow the engine to recover up to the proper RPM.

6. Set throttle at the full-throttle position.
7. Steer and accelerate mower using the steering speed control levers.



Start Up and Operation of Mower (continued)

To Stop The Mower:

NOTE: In case of emergency, engine may be stopped by turning the ignition key to the OFF position.

1. Move steering speed control levers to neutral position to stop mower movement.
2. Push deck engaging switch (PTO) down to disengage mower deck blades.
3. Pull parking brake lever all the way up to set parking brake.
4. Move throttle to the idle position.
5. Allow engine to idle for two minutes before turning key off.
6. Turn ignition key to the OFF position and remove key, even if leaving mower unattended for only a few minutes.
7. Depress deck foot pedal to raise mower deck to highest position. Engage deck lock handle.

Safety Interlock System

The mower has a system of safety interlock switches that will **not** allow the mower to start unless these conditions are met:

- Steering speed control levers in neutral lock position
- Parking brake set
- Deck engaging switch (PTO) off
- Seat is occupied

If the seat is vacated during mowing, without positioning the controls as previously outlined, the engine will be stopped by the safety interlock system.

Deck Height Adjustment

Set the mowing deck appropriately to achieve the desired height of your cut. The recommended cutting height is 2-3 inches (5-7 cm), though your preference may be a higher or lower cut. Tall grasses or weeds should be cut with the mower deck set to its highest position.

The first time you mow, set the cut height to a little higher than normal, then adjust accordingly as follows:

1. Refer to the orange deck height indicator decal, directly to the left of the deck height adjustment rod.
2. Determine the appropriate notch setting for your desired cut height.
3. Depress the deck foot pedal to lift deck, then lock the deck in the highest position with the deck lock handle.
4. Reposition the deck height stop to the selected notch setting, then depress the deck foot pedal, release the deck lock, slowly release pressure on deck foot pedal to lower deck to new height setting.

DIXIE CHOPPER

Start-Up and Operation of Mower (continued)

Steering Speed Control Levers

DANGER

Do not move the steering speed control levers too rapidly, or start and stop the mower suddenly, especially on grades. Failure to comply will result in personal injury or death.

The mower is equipped with a separate hydraulic pump and motor for each rear wheel. The pumps are controlled by the steering speed control levers. The left lever controls the left rear wheel and the right lever controls the right rear wheel.

To move forward, push both levers forward at the same time, slowly and evenly.

To speed up the forward movement, push levers farther forward away from you. The farther forward they are pushed, the faster the mower will travel.

To move in reverse, pull both levers backward at the same time, slowly and evenly.

To speed up the backward movement, pull levers farther back toward you. The farther back toward you they are pulled, the faster the mower will travel.

To turn, slow the mower's ground speed, then further slow the speed of the right wheel for a right-hand turn, or the left wheel for a left-hand turn.

Refer to illustration shown below of steering speed control levers' position relative to mower wheels and the direction in which the levers turn them.

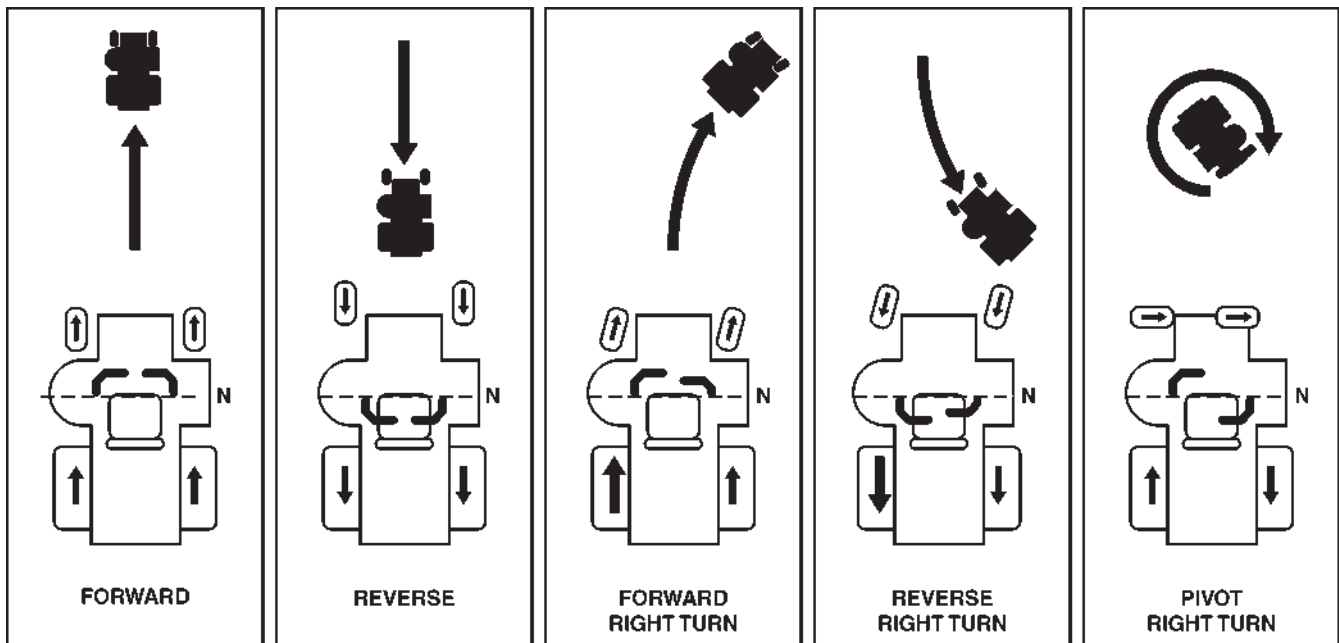



Start-Up and Operation of Mower (continued)

Zero Radius Turning

To execute a zero degree turn, you **must** put one wheel in reverse and one wheel in forward.

Until you have practiced this procedure and acquired a feel for the machine, it is possible to damage the turf due to an incorrect input. Please be aware of and mindful that it is possible to pull the levers back toward the operator in such a manner that the drive wheels will spin in reverse. This is also true for the reverse direction, that is, if the machine is traveling in a reverse direction and the levers are suddenly and quickly pushed away from the operator, it is possible that the drive wheels will attempt to spin forward. Failure to follow the correct procedure for zero degree turns could result in damage to the turf. When learning the zero degree turning procedure, use reduced engine RPM and *extreme caution*.

Moving the Mower Without Power

NOTE: Do not exceed a speed of 2 mph when moving the mower without power.

In order to transport the mower without power, you must first release the hydraulic pressure by using the bypass valve located on each pump. Lift the mower seat to gain access to the pump valves. The valves are a 5/8" hex head located on the valve block of each of the pumps, with a cross hole through it. Loosen the bypass valve on each pump, three turns counterclockwise. Move the mower. Tighten the bypass valve on each pump, three turns clockwise.

Optimum Performance = Best Results

The mower is designed to operate most efficiently at maximum blade speeds, which are achieved with maximum engine speed. The ground speed of the mower should allow the mower deck blades to maintain that maximum efficient speed. Therefore, slow the ground speed of the mower when cutting tall grass, grass heavy with moisture, or mowing uphill, so as to maintain maximum blade speed.

If ground speed is too fast or blade speed is too slow, an uneven cut will result.

Make sure that mower deck blades are sharp to ensure the optimum quality of cut. Refer to Blade Replacement and Blade Sharpening procedures for detailed instructions on how to safely and properly maintain and sharpen mower blades.



Basic Mower Adjustments, Maintenance, and Repairs

Blade Replacement

DANGER *Never work with mower blades while mower is running. Make sure that ignition switch is off and key removed, PTO switch is disengaged, steering speed control levers are in neutral lock, and parking brake is on. Failure to comply will result in personal injury or death.*

WARNING *Disconnect the spark plug wire and place the wire where it cannot contact spark plug when setting up, adjusting, doing repairs on, or transporting your mower. Mower can accidentally start if spark plug wire is connected. Failure to comply can result in personal injury or death.*

CAUTION *Use caution when handling mower blades during replacement or maintenance. Wear appropriate protective gloves and clothing and cover the sharp cutting edges of the blades. Failure to comply can result in personal injury.*

1. Lift front end of mower and support it with a jack or jack stands with a sufficient safe working load capacity.
2. Wedge a short piece of 2x4 lumber between the mower blade and the mower deck to immobilize the blade while removing attaching hardware.
3. Remove bolts, washers, and spacer attaching blade to blade shaft, and remove blades.
4. Apply anti-seize compound to threads of attaching bolts before installation.
5. In reverse order as removed, install new or sharpened blade with spacer, washers, and bolts. Make certain to keep the air lift area (turned up section) of blade facing the underside of mower deck. Ensure that the fiber washer (which acts as a vibration damper) is against the blade.

6. Tighten bolts to a torque of 80-100 ft-lbs (108-135 N•m).

Blade Sharpening

CAUTION *Use caution when handling mower blades during replacement or maintenance. Wear appropriate protective gloves and clothing and cover the sharp cutting edges of the blades. Failure to comply can result in personal injury.*

CAUTION *Newly sharpened blades must be balanced using a blade balancer before reinstalling them. Failure to comply can result in severe damage to equipment.*

NOTE: Replacing the mower blades is the preferred method of ensuring your mower blades are sharp. Sharpening blades yourself is not recommended. However, if you choose to do so, the blades **must** be balanced after being sharpened.

1. Remove blades as outlined in Blade Replacement procedure.
2. Sharpen the blades using a hand grinder.
3. Balance the blades using a cone blade balancer following the instructions supplied with balancer.
4. Install newly sharpened blades as outlined in Blade Replacement procedure.



Basic Mower Adjustments, Maintenance, and Repairs (continued)

Under Deck Cleaning

DANGER *Never attempt to make any adjustments to mower deck or work under it while mower is running. Make sure that ignition switch is off and key removed, PTO switch is disengaged, steering speed control levers are in neutral lock, and parking brake is on. Failure to comply will result in personal injury or death.*

CAUTION *Do not clean the underside of the deck with a pressure washer. Water can get in and under seals and cause damage to equipment.*

Clean the underside of the deck frequently. Accumulation of matter clippings seriously impairs the mower's ability to "lift" the grass into cutting position and discharge the clippings evenly. Matted grass clogging the underside of the mower deck is often the cause of uneven cutting.

Deck Level Check

DANGER *Never attempt to make any adjustments to mower deck or work under it while mower is running. Make sure that ignition switch is off and key removed, PTO switch is disengaged, steering speed control levers are in neutral lock, and parking brake is on. Failure to comply will result in personal injury or death.*

An uneven or lopsided cut may be caused by an out-of-level mowing deck. If the quality of your cut is not optimum, check for an out-of-level deck as follows:

1. Park mower on level surface.
2. Check tire pressure to make sure they are inflated to the proper pressure levels. Both front tires should be inflated to 12 psi, and both rear tires should be inflated to 7 psi.
3. If any tire's pressure is not correct, correct the pressure(s) to the appropriate pressure level

Make another pass with the mower to check the evenness of cut.

4. If cut is still uneven, check levelness of blades. Adjust deck height to the level for a 3-inch cut. Refer to Controls and Indicators page 12. Make sure deck height stop is turned so that the wide side faces the rear.
5. Make sure that the blades are positioned with the tips of blades pointing toward front and back of mower. On right-hand side, measure the distance from front tip of blade to ground. Note measurement. Repeat this process for the left-hand side blade. Both front blade tips should measure 3 inches, +/- 1/8 inch, from tip to ground.
6. On the right-hand side, measure the distance from back tip of blade to ground. Repeat this process for the left-hand side blade. Both front blade tips should measure 3 inches, +/- 1/8 inch from tip to ground.

NOTE: There can be a 1/4-inch variation between the forward pitch of the front and back blade measurements. For example, both front blade tips could measure 3 inches from the ground, and both back blade tips could measure 3-1/4 inches from the ground.

7. If blade to ground measurements are even, but cut is uneven, consult the Service Department of your authorized Dixie Chopper dealer.



Basic Mower Adjustments, Maintenance, and Repairs (continued)

Drive Belt Adjustment

DANGER *Never attempt to make any adjustments to mower deck or work under it while mower is running. Make sure that ignition switch is off and key removed, PTO switch is disengaged, steering speed control levers are in neutral lock, and parking brake is on. Failure to comply will result in personal injury or death.*

There are two drive belts that can need periodic adjustment: the drive belt from the engine to the pumps, and the drive belt from the engine to the mower deck.

These belts may be adjusted as follows:

1. Gain access to the underside of mower.
2. Adjust the drive belt from engine to pump at the spring tensioner located near the left rear wheel. Tighten the jamnut until spring measures 2 inches.
3. Adjust the drive belt from engine to mower deck at the spring tensioner located at the back of the mower deck. Tighten the jamnut until spring measures 3 inches.

Drive Belt Replacement

DANGER *Never attempt to make any adjustments to mower deck or work under it while mower is running. Make sure that ignition switch is off and key removed, PTO switch is disengaged, steering speed control levers are in neutral lock, and parking brake is on. Failure to comply will result in personal injury or death.*

Replace the drive belts if they show signs of cuts, tears, burns caused by slipping, or excessive wear. Refer to the Routine Maintenance section of this manual for a schedule of replacement.

1. Gain access to underside of mower.
2. Loosen the tension on the vertical/horizontal idler pulley by pulling it away from belt.
3. Roll belt off the pulley, noting the routing of belt.
4. Roll new belt onto pulley, routing it in the same configuration as belt just removed. Manipulate pulley as needed.

Parking Brake Adjustment

1. Set the parking brake to off (handle down).

If brake looseness is equal on both sides of mower, perform steps 2 and 3 only. If brake looseness is on only one side or the other, skip to step 4.

2. Lift mower seat.
3. Tighten the front brake linkage adjustment nut.
4. Remove applicable tire.
5. Remove cotter pin.
6. Pull out brake link.
7. Loosen jamnut.
8. Turn brake link two revolutions clockwise.
9. Tighten jamnut.
10. Replace brake link.
11. Install cotter pin.
12. Install tire. Torque tire lug nuts to 100 ft-lbs.

Steering Linkage Adjustment

1. Place steering speed control levers in the neutral lock position.
2. Chock front tires.
3. Jack up mower enough so that back tires are off the ground. Use a jack with a sufficient safe working load capacity of at least 1/2 ton.



Basic Mower Adjustments, Maintenance, and Repairs (continued)

4. With the motor running, loosen steering linkage jamnut.
5. Pull cotter pin.
6. Pull clevis pin out of yoke in pump control arm.

NOTE: Early Silver Eagle models include a flat washer. If your unit is so equipped, be certain to keep washer with clevis pin on the outside edge.

7. Adjust pump control arm until wheel stops turning.
8. Adjust the hole in the yoke on steering linkage to align with the hole in the pump control arm.
9. Install clevis pin.
10. Install cotter pin.
11. Remove wheel chocks.
12. Lower mower from jack.

Mercury Switch Replacement

WARNING *This component contains mercury, a chemical known to be toxic to human beings. Dispose of switch only in accordance with local, state, and federal EPA regulations.*

1. Remove fasteners from control panel and remove panel.
2. Remove mercury switch from its holder.
3. Cut both wires extending from mercury switch a few inches from switch.
4. Retain old mercury switch for proper recycling in accordance with state regulations.
5. Splice wires of new mercury switch onto electrical harness wires.
6. Install switch into holder.
7. Install control panel with fasteners.

Battery Maintenance

Follow the instructions provided with the Kohler engine manual.

During off-season storage, use a trickle charger to maintain the battery.

Mower Cleaning and Off-Season Storage

After 30 days of use, painted surfaces of the mower may be waxed to protect the luster of the original finish. Wash the mower regularly with a mild automotive type detergent and water. Exposed bare metal surfaces should be coated with oil, or a light coating of grease, to prevent rust until permanent repairs can be made. Touch-up paint is available through your authorized Dixie Chopper dealer.

Clean and store the mower at the end of the mowing season as follows:

1. Perform steps as applicable under Routine Maintenance.
2. Remove all grass, dirt, and debris from tractor and mower. Wash mower and repaint all bare metal surfaces.
3. Thoroughly lubricate machine according to lubrication instructions.
4. Check hydraulic oil level. Add oil if necessary. Change oil and filter if not done in last 500 hours. Refer to Routine Maintenance.
5. Check tires for proper inflation.



Basic Mower Adjustments, Maintenance, and Repairs (continued)

CAUTION

Do not store gasoline for more than 2 months. Failure to comply can cause damage to equipment or personal injury.

6. Start mower and engage mower for approximately one minute to remove excess water from belts and pulleys. Let engine run out of gas. Gasoline forms harmful gum and varnish deposits in the carburetor and fuel system as it becomes old.

CAUTION

Do not jump-start the battery. A charge of 1.75 amps or more, as with a jump start, will damage the fuel-injection computer. Use a trickle charger of 1.5 amps or less to keep battery charged.

7. Fully charge battery to prevent freezing and internal damage in weather below 32°F (0°C). In temperatures above 40°F (4°C), check water level and trickle charge battery during storage.

Prepare the engine for storage at the end of the mowing season as follows:

1. Run engine for 15 minutes or longer.
2. Drain oil while engine is still warm.
3. Refill crankcase with fresh oil. Refer to Routine Maintenance for proper oil type.
4. Drain fuel tanks and run engine until it runs out of gas.
5. Remove and replace fuel filter if not done in the previous 100 hours of operation.
6. Remove spark plugs. Pour a tablespoon of engine oil into each spark plug hole and install plugs. Do not connect plug leads.
7. Crank engine with starter at least a dozen revolutions to distribute oil over cylinder walls and valve mechanism.

8. Clean exterior surfaces of engine and spread a light coat of oil over any exposed metal surfaces of engine subject to corrosion.
9. Clean dirt and chaff from the cylinders, fins, blower housing, and muffler.
10. Check oil filler and fuel tank caps to make sure they're securely in place.

Mower Preparation for New Mowing Season

Prepare the stored mower for the new mowing season as follows:

1. Clean mower and remove any debris and dirt accumulation.
2. Check the hydraulic and engine oil levels.
3. Fill fuel tanks with fresh gasoline.
4. Run the engine at half speed for 5 minutes and check the operation of the steering speed control levers. Then, stop engine and check for oil leaks, loose fittings, etc.
5. Install all safety shields (if removed) and review the General Safety Precautions listed in the front of this manual.
6. Check air pressure in tires. If needed, inflate to proper pressure: front tires 12 psi and back tires 7 psi.

DIXIE CHOPPER

OCDC (OPTIONAL)

OPERATOR CONTROLLED DISCHARGE CHUTE

Operation

This machine may be equipped with an Operator Controlled Discharge Chute. This discharge chute has a variable adjustment from full open to full closed. In the full closed position it will serve to keep some of the clipping materials under the mower deck for a longer period of time in order to enhance the mulching capabilities as well as functioning as a discharge safety shield. This discharge chute should ALWAYS BE OPERATED IN THE DOWN POSITION WHEN MOWING WHILE PEOPLE ARE PRESENT IN THE IMMEDIATE VICINITY. Mulching may not be possible in some cutting conditions. In extremely wet conditions you may have to run the OCDC in the open position to facilitate proper material discharge and avoid wind-rowing.

Controls

1. Handle - Used to raise and lower discharge chute.
2. Discharge Plate.

NOTE: SAFE OPERATION OF THIS VEHICLE IS THE SOLE RESPONSIBILITY OF THE OPERATOR. SAFETY IS AN ATTITUDE AND IT STARTS WITH YOU!

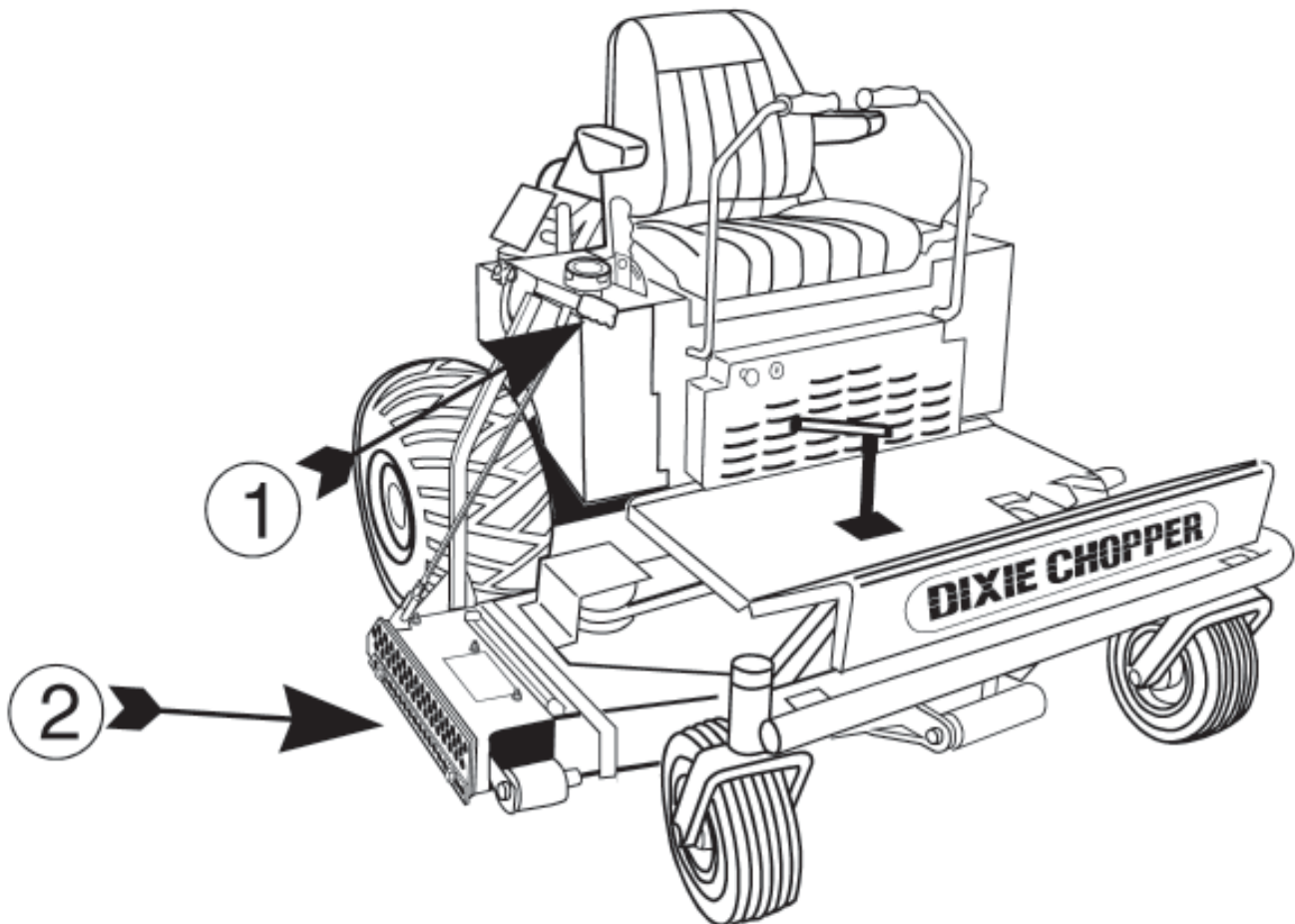



Routine Maintenance

Daily Checks	Check Engine Oil Level Follow Manufacturer's Recommendations	Check Hydraulic Oil Level Dixie Chopper VTC Hydraulic Oil	Check Tire Pressure Rear Tires: 7 psi Front Tires: 12 psi
---------------------	---	--	---

Every 100 Hours	Change Engine Oil and Filter Follow Manufacturer's Recommendations	Replace Air Filter (DO NOT BLOW OUT WITH COMPRESSED AIR)	Check Engine to Hydraulic Pumps Belt Tension Tension Spring compressed to 2"
	Check Battery Fluid Level (If applicable)	Check Engine to Mower Deck Tension Tension Spring compressed to 3"	Lube Deck Spindle Assemblies

Every 1000 Hours or Annually	Change Hydraulic Filters		Remove Belts and Check Spindle Bearings, Idlers, and Pulleys.
	Lube Front Caster Bearings	Clean or Replace Spark Plugs	Check Steering for Creep in the Neutral Position
	Check Front and Rear Tires for Tread Wear	Replace Engine Fuel Filter(s)	Change Hydraulic Drive Oil Dixie Chopper VTC Hydraulic Oil
	Change Hydraulic Drive Oil <i>DO NOT USE HYDRAULIC OIL, HYTRAN, OR AUTOMATIC TRANSMISSION FLUID.</i> USE ONLY A HIGH-GRADE 10W50, 15W40, 15W50, OR 20W50 MOTOR OIL THAT MEETS THE MINIMUM VISCOSITY REQUIREMENTS OF 89 SUS or BETTER AT 212°F.		

NOTE: The recommended Hydraulic Drive oil for your Dixie Chopper machine is D/C VTC Hydraulic Oil (Part Number 4940002106). We strongly urge that you use this oil in the event that you should need to refill or add to your hydraulic reservoir.

Engine Oil: Under Normal Mowing Conditions, Use 10W30.
For Cold Weather Operation, Consult Engine Manual.

Lube Grease: High Temperature Lithium Grease.

DIXIE CHOPPER

LUBRICATION POINTS



Every 100
Hours

Right Side Deck Drive Hub

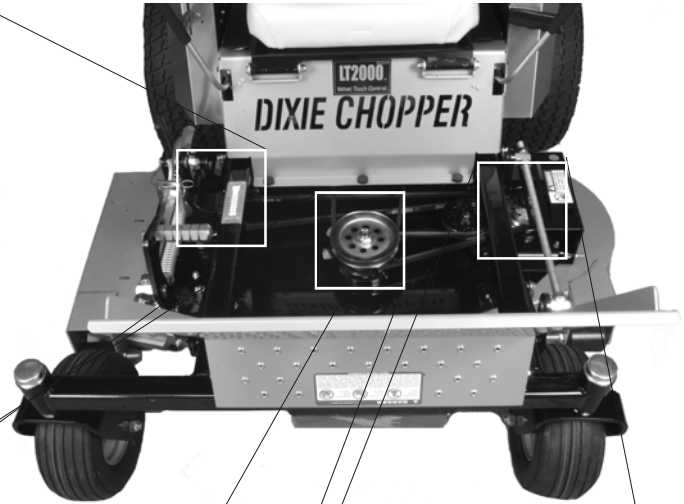

Every 100
Hours

Center Deck Drive Hub

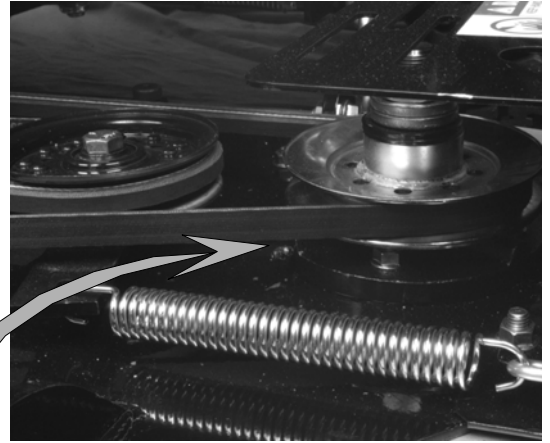

Every 100
Hours

Left Side Deck Drive Hub

DIXIE CHOPPER

LUBRICATION POINTS

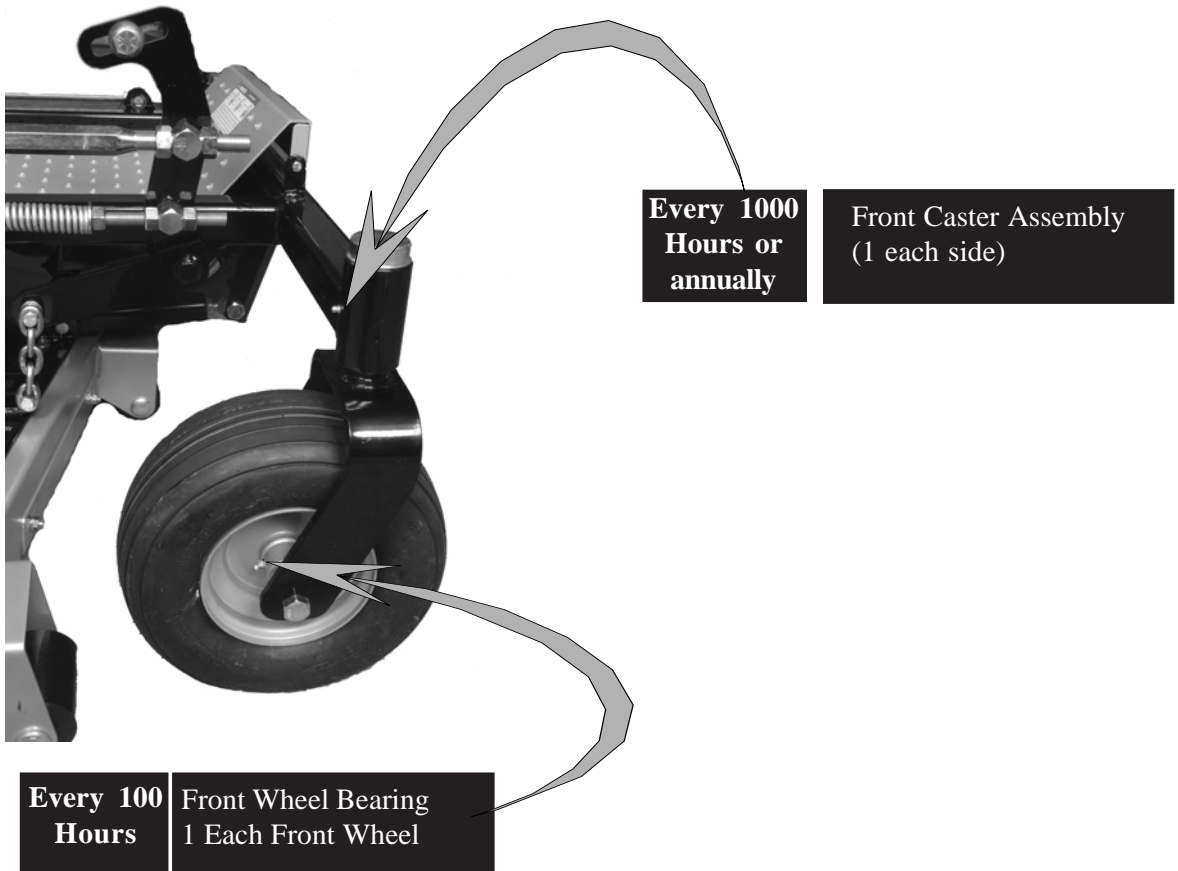

DIXIE CHOPPER

NOTES

DIXIE CHOPPER

NOTES

DIXIE CHOPPER[™]

Magic Circle Corporation
6302 E. County Road 100 North
Coatesville, IN. 46121
765-246-6845
765-246-6146 Fax
www.dixiechopper.com



Dixie Chopper, Magic Circle, and the Magic Circle Atom Logo are all trademarks of the Magic Circle Corporation, and may not be reproduced without permission.

Printed in the USA

Specifications and instructions are subject to change without notice.

Print Date: 02/2003