

eXmark®

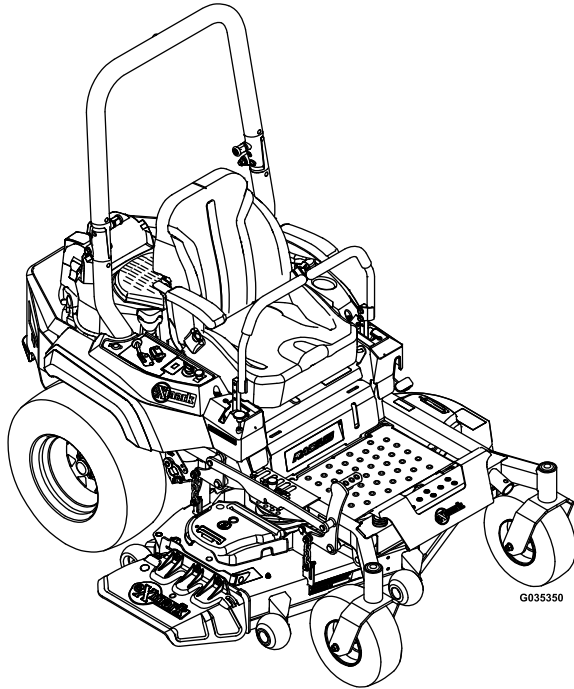

RADIUS®

**For Serial Nos.
400,000,000 & Higher**
Part No. 4502-907 Rev. B

Operator's Manual

⚠ WARNING

CALIFORNIA
Proposition 65 Warning

This product contains a chemical or chemicals known to the State of California to cause cancer, birth defects, or reproductive harm.

The engine exhaust from this product contains chemicals known to the State of California to cause cancer, birth defects, or other reproductive harm.

Important: It is a violation of California Public Resource Code Section 4442 or 4443 to use or operate the engine on any forest-covered, brush-covered, or grass-covered land unless the engine is equipped with a spark arrester, as defined in Section 4442, maintained in effective working order or the engine is constructed, equipped, and maintained for the prevention of fire.

To acquire a spark arrester for your unit, see your Engine Service Dealer.

This spark ignition system complies with the Canadian standard ICES-002. Ce système d'allumage par étincelle de véhicule est conforme à la norme NMB-002 du Canada.

For all models that do not have Exmark engines, please refer to the engine manufacturer's information included with the machine.

Labeled power ratings are supplied by the engine manufacturer in accordance with SAE testing and gross/net power rating standards (J1940, J1995, J1349).

Exmark reserves the right to make changes or add improvements to its products at any time without incurring any obligation to make such changes to products manufactured previously. Exmark, or its distributors and dealers, accept no responsibility for variations which may be evident in the actual specifications of its products and the statements and descriptions contained in this publication.



If your Exmark dealer does not have the Exmark part in stock, Exmark will get the parts to the dealer the next business day or the part will be FREE Guaranteed!! (Some restrictions apply. See your participating Exmark Dealer for details.)

Introduction

CONGRATULATIONS on the purchase of your Exmark Mower. This product has been carefully designed and manufactured to give you a maximum amount of dependability and years of trouble-free operation.

This manual contains operating, maintenance, adjustment, and safety instructions for your Exmark mower.

BEFORE OPERATING YOUR MOWER, CAREFULLY READ THIS MANUAL IN ITS ENTIRETY.

By following the operating, maintenance, and safety instructions, you will prolong the life of your mower, maintain its maximum efficiency, and promote safe operation.

Important: To maximize safety, performance, and proper operation of this machine, it is essential that all operators carefully read and fully understand the contents of the Operator's manual provided with the product. Safe operation of Exmark equipment is essential. Failure to comply with the operating instructions or receive proper training may result in injury. Go to <http://www.Exmark.com> for additional safe operation information, such as safety tips, training materials, and Operator's manuals.

If additional information is needed, or should you require trained mechanic service, contact your authorized Exmark equipment dealer or distributor.

All Exmark equipment dealers and distributors are kept informed of the latest methods of servicing and are equipped to provide prompt and efficient service in the field or at their service stations. They carry ample stock of service parts or can secure them promptly for you from the factory.

All Exmark parts are thoroughly tested and inspected before leaving the factory, however, attention is required on your part if you are to obtain the fullest measure of satisfaction and performance.

Whenever you need service, genuine Exmark parts, or additional information, contact an Authorized Service Dealer or Exmark Customer Service and have the model and serial numbers of your product ready.

Figure 1 identifies the location of the model and serial numbers on the product. Write the numbers in the space provided.

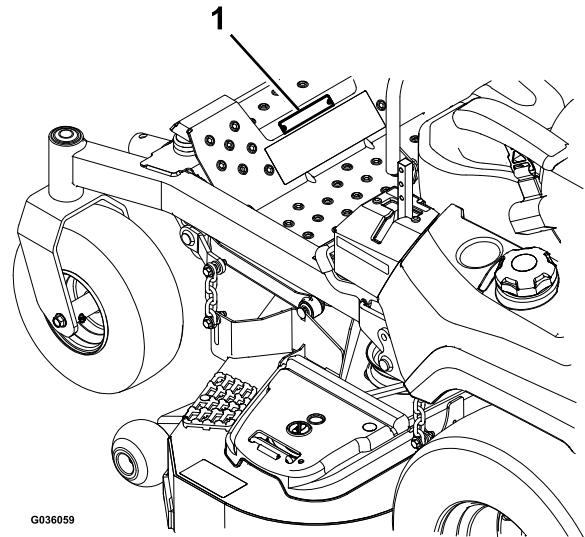

Figure 1

1. Model and serial number location

Model No. _____
Serial No. _____

Contents

Introduction	3	Deck Belt Tension	65
Safety	5	Adjusting the Parking Brake	65
Safety Alert Symbol	5	Motion Control Handle Adjustment	66
Safe Operating Practices	5	Full Forward Tracking Adjustment.....	66
Safety and Instructional Decals	11	Motion Control Linkage Adjustment	67
Specifications	18	Adjusting the Seat Ride SuspensionS-Series Only.....	68
Systems	18	Electric Clutch Adjustment.....	68
Dimensions.....	21	Cleaning	69
Torque Requirements	23	Clean Engine and Exhaust System Area	69
Product Overview	23	Remove Engine Shrouds and Clean Cooling Fins.....	69
Operation	24	Clean Debris From Machine	69
Controls.....	24	Clean Grass Build-Up Under Deck	69
Pre-Start.....	26	Waste Disposal.....	69
Operating Instructions	27	Troubleshooting	71
Transporting	32	Schematics	73
Maintenance	35		
Recommended Maintenance Schedule(s)	35		
Periodic Maintenance	36		
Engine Maintenance.....	36		
Servicing the Engine Oil.....	40		
Servicing the Spark Plug-Exmark 708cc Engine	48		
Servicing the Spark Plug-Kohler Engine	50		
Servicing the Spark Plug-Kawasaki Engine	51		
Check Battery Charge.....	52		
Check Mower Blades	53		
Check Safety Interlock System	55		
Check Rollover Protections Systems (Roll Bar) Knobs.....	58		
Check Seat Belt.....	58		
Check for Loose Hardware	58		
Check Hydraulic Oil Level.....	58		
Check Tire Pressures	58		
Check Condition Of Belts.....	58		
Lubricate Grease Fittings.....	59		
Replace Emissions Air Intake Filter (If Applicable).....	60		
Change Hydraulic System Filter and Fluid	61		
Check Spark Arrester (if equipped).....	62		
Thread Locking Adhesives.....	62		
Copper-Based Anti-seize	62		
Dielectric Grease.....	62		
Adjustments	63		
Deck Leveling	63		
Adjusting the Blade Slope	64		
Pump Drive Belt Tension.....	65		

Safety

Safety Alert Symbol

This lawn mower meets or exceeds the B71.4 specifications of the American National Standards Institute in effect at the time of production.

Exmark designed and tested this lawn mower to offer reasonably safe service; however, failure to comply with the following instructions may result in personal injury.

This Safety Alert Symbol (Figure 2) is used both in this manual and on the machine to identify important safety messages which must be followed to avoid accidents.

This symbol means: **ATTENTION! BECOME ALERT! YOUR SAFETY IS INVOLVED!**



Figure 2
Safety Alert Symbol

The safety alert symbol appears above information which alerts you to unsafe actions or situations and will be followed by the word **DANGER**, **WARNING**, or **CAUTION**.

DANGER: Indicates an imminently hazardous situation which, if not avoided, **Will** result in death or serious injury.

WARNING: Indicates a potentially hazardous situation which, if not avoided, **Could** result in death or serious injury.

CAUTION: Indicates a potentially hazardous situation which, if not avoided, **May** result in minor or moderate injury.

This manual uses two other words to highlight information. **Important** calls attention to special mechanical information and **Note** emphasizes general information worthy of special attention.

Safe Operating Practices

Training

- Read the Operator's Manual and other training material. If the operator(s) or mechanic(s) can not read this manual, it is the owner's responsibility to explain this material to them; other languages may be available on our website.
- Become familiar with the safe operation of the equipment, operator controls, and safety signs.
- All operators and mechanics should be trained. The owner is responsible for training the users.
- Never let children or untrained people operate or service the equipment. Local regulations may restrict the age of the operator.
- Only adults and mature teenagers should operate a mower, and even mature teenagers should have adult supervision. Be sure a teenager:
 1. has read and understands the Operator's Manual and recognizes the risks involved;
 2. is sufficiently mature to use caution; and
 3. is of sufficient size and weight to operate the controls comfortably and to manage the mower without taking risks.
- The owner/user can prevent and is responsible for accidents or injuries occurring to himself or herself, other people or property.

Preparation

- Evaluate the terrain to determine what accessories and attachments are needed to properly and safely perform the job. Only use accessories and attachments approved by Exmark.
- Wear appropriate clothing including safety glasses, substantial slip-resistant footwear, and hearing protection. Long hair, loose clothing or jewelry may get tangled in moving parts.

⚠ CAUTION

This machine produces sound levels in excess of 85 dBA at the operator's ear and can cause hearing loss through extended periods of exposure.

Wear hearing protection when operating this machine.

- Inspect the area where the equipment is to be used and remove all rocks, toys, sticks, wires,

bones, and other foreign objects which can be thrown by the machine and may cause personal injury to the operator or bystanders.

▲ DANGER

In certain conditions gasoline is extremely flammable and vapors are explosive.

A fire or explosion from gasoline can burn you, others, and cause property damage.

- Fill the fuel tank outdoors on level ground, in an open area, when the engine is cold. Wipe up any gasoline that spills.
- Never refill the fuel tank or drain the machine indoors or inside an enclosed trailer.
- Do Not fill the fuel tank completely full. Fill the fuel tank to the bottom of the filler neck. The empty space in the tank allows gasoline to expand. Overfilling may result in fuel leakage or damage to the engine or emission system.
- Never smoke when handling gasoline, and stay away from an open flame or where gasoline fumes may be ignited by spark.
- Store gasoline in an approved container and keep it out of the reach of children.
- Add fuel before starting the engine. Never remove the cap of the fuel tank or add fuel when engine is running or when the engine is hot.
- If fuel is spilled, Do Not attempt to start the engine. Move away from the area of the spill and avoid creating any source of ignition until fuel vapors have dissipated.
- Do Not operate without entire exhaust system in place and in proper working condition.

▲ DANGER

In certain conditions during fueling, static electricity can be released causing a spark which can ignite gasoline vapors. A fire or explosion from gasoline can burn you and others and cause property damage.

- Always place gasoline containers on the ground away from your vehicle before filling.
- Do Not fill gasoline containers inside a vehicle or on a truck or trailer bed because interior carpets or plastic truck bed liners may insulate the container and slow the loss of any static charge.
- When practical, remove gas-powered equipment from the truck or trailer and refuel the equipment with its wheels on the ground.
- If this is not possible, then refuel such equipment on a truck or trailer from a portable container, rather than from a gasoline dispenser nozzle.
- If a gasoline dispenser nozzle must be used, keep the nozzle in contact with the rim of the fuel tank or container opening at all times until fueling is complete. Do Not use a nozzle lock open device.

▲ WARNING

Gasoline is harmful or fatal if swallowed. Long-term exposure to vapors has caused cancer in laboratory animals. Failure to use caution may cause serious injury or illness.

- Avoid prolonged breathing of vapors.
 - Keep face away from nozzle and gas tank/container opening.
 - Keep away from eyes and skin.
 - Never siphon by mouth.
- Check that the operator presence controls, safety switches, and shields are attached and functioning properly. Do Not operate unless they are functioning properly.

Operation

⚠ WARNING

Operating engine parts, especially the muffler, become extremely hot. Severe burns can occur on contact and debris, such as leaves, grass, brush, etc. can catch fire.

- Allow engine parts, especially the muffler, to cool before touching.
- Remove accumulated debris from muffler and engine area.

⚠ WARNING

Engine exhaust contains carbon monoxide, which is an odorless deadly poison that can kill you.

Do Not run engine indoors or in a small confined area where dangerous carbon monoxide fumes can collect.

- Operate only in daylight or good artificial light, keeping away from holes and hidden hazards.
- Lightning can cause severe injury or death. If lightning is seen or thunder is heard in the area, Do Not operate the machine; seek shelter.
- Be sure all drives are in neutral and parking brake is engaged before starting engine. Use seat belts with the roll bar in the raised and locked position.
- Never operate the mower with damaged guards, shields, or covers. Always have safety shields, guards, switches and other devices in place and in proper working condition.
- Never mow with the discharge deflector raised, removed or altered unless there is a grass collection system or mulch kit in place and working properly.
- Do Not change the engine governor setting or overspeed the engine.
- Park machine on level ground. Stop engine, wait for all moving parts to stop, remove key and engage parking brake:
 - Before checking, cleaning or working on the mower.
 - After striking a foreign object or abnormal vibration occurs (inspect the mower for

damage and make repairs before restarting and operating the mower).

- Before clearing blockages.
- Whenever you leave the mower.
- Stop engine, wait for all moving parts to stop, and engage parking brake:
 - Before refueling.
 - Before dumping the grass catcher.

⚠ WARNING

Hands, feet, hair, clothing, or accessories can become entangled in rotating parts. Contact with the rotating parts can cause traumatic amputation or severe lacerations.

- Do Not operate the machine without guards, shields, and safety devices in place and working properly.
- Keep hands, feet, hair, jewelry, or clothing away from rotating parts.
- **NEVER** carry passengers. **DO NOT** operate the mower when people, especially children, or pets are in the area.
- Be alert, slow down and use caution when making turns. Look behind and to the side before changing directions.
- Stop the blades, slow down, and use caution when crossing surfaces other than grass and when transporting the mower to and from the area to be mowed.
- Be aware of the mower discharge path and direct discharge away from others.
- Do Not operate the mower under the influence of alcohol or drugs.
- Use extreme care when loading or unloading the machine into a trailer or truck.
- Use care when approaching blind corners, shrubs, trees, or other objects that may obscure vision.

Slope Operation

Use **Extreme** caution when mowing and/or turning on slopes as loss of traction and/or tip-over could occur. The operator is responsible for safe operation on slopes.

▲ DANGER

Operating on wet grass or steep slopes can cause sliding and loss of control. Wheels dropping over edges, ditches, steep banks, or water can cause rollovers, which may result in serious injury, death or drowning.

- Do Not mow slopes when grass is wet.
- Do Not mow near drop-offs or near water.
- Do Not mow slopes greater than 15 degrees.
- Reduce speed and use extreme caution on slopes.
- Avoid sudden turns or rapid speed changes.
- Keep the roll bar in the raised and locked position and use seat belt.
- See inside the back cover to determine the approximate slope angle of the area to be mowed.
- Use a walk behind mower and/or a hand trimmer near drop-offs, ditches, steep banks or water. (Figure 3).

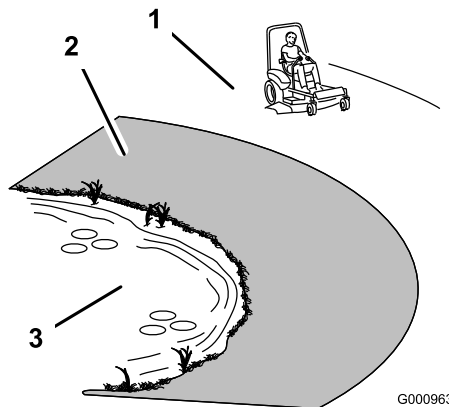

Figure 3

1. Safe Zone-Use the mower here on slopes less than 15 degrees
2. Danger Zone-Use a walk behind mower and/or hand trimmer on slopes greater than 15 degrees, near drop-offs and water.
3. Water

- Remove or mark obstacles such as rocks, tree limbs, etc. from the mowing area. Tall grass can hide obstacles.
- Watch for ditches, holes, rocks, dips and rises that change the operating angle, as rough terrain could overturn the machine.
- Avoid sudden starts when mowing uphill because the mower may tip backwards.

- Be aware that operating on wet grass, across steep slopes or downhill may cause the mower to lose traction. Loss of traction to the drive wheels may result in sliding and a loss of braking and steering.
- Always avoid sudden starting or stopping on a slope. If tires lose traction, disengage the blades and proceed slowly off the slope.
- Follow the manufacturer's recommendations for wheel weights or counter weights to improve stability.
- Use extreme care with grass catchers or attachments. These can change the stability of the machine and cause loss of control.

Using the Rollover Protection System (ROPS)

A Rollover Protection System (roll bar) is installed on the unit.

▲ WARNING

There is no rollover protection when the roll bar is down. Wheels dropping over edges, ditches, steep banks, or water can cause rollovers, which may result in serious injury, death or drowning.

- Do Not remove the ROPS.
- Keep the roll bar in the raised and locked position and use seat belt.
- Lower the roll bar only when absolutely necessary.
- Do Not wear seat belt when the roll bar is down.
- Drive slowly and carefully.
- Raise the roll bar as soon as clearance permits.
- Be certain that the seat belt can be released quickly in the event of an emergency.
- Check carefully for overhead clearances (i.e. branches, doorways, and electrical wires) before driving under any objects and Do Not contact them.
- In the event of a rollover, take the unit to an Authorized Service Dealer to have the ROPS inspected.

- Replace a damaged ROPS. Do Not repair or revise.
- Any accessories, alterations, or attachments added to the ROPS must be approved by Exmark.

Maintenance and Storage

- Disengage drives, set parking brake, stop engine and remove key or disconnect spark plug wire. Wait for all movement to stop before adjusting, cleaning or repairing.
- Keep engine and engine area free from accumulation of grass, leaves, excessive grease or oil, and other debris which can accumulate in these areas. These materials can become combustible and may result in a fire.
- Let engine cool before storing and Do Not store near flame or any enclosed area where open pilot lights or heat appliances are present.
- Shut off fuel while storing or transporting. Do Not store fuel near flames or drain indoors.
- Park machine on level ground. Never allow untrained personnel to service machine.
- Use jack stands to support components when required.
- Carefully release pressure from components with stored energy.
- Disconnect battery or remove spark plug wire before making any repairs. Disconnect the negative terminal first and the positive last. Reconnect positive first and negative last.
- Use care when checking blades. Wrap the blade(s) or wear gloves, and use caution when servicing them. Only replace damaged blades. Never straighten or weld them.
- Keep hands and feet away from moving parts. If possible, Do Not make adjustments with the engine running.
- Charge batteries in an open well ventilated area, away from spark and flames. Unplug charger before connecting or disconnecting from battery. Wear protective clothing and use insulated tools.

⚠ DANGER

Charging or jump starting the battery may produce explosive gases. Battery gases can explode causing serious injury.

- Keep sparks, flames, or cigarettes away from battery.
- Ventilate when charging or using battery in an enclosed space.
- Make sure venting path of battery is always open once battery is filled with acid.
- Always shield eyes and face from battery.

⚠ DANGER

Battery electrolyte contains sulfuric acid, which is poisonous and can cause severe burns. Swallowing electrolyte can be fatal or if it touches skin can cause severe burns.

- Wear safety glasses to shield eyes, and rubber gloves to protect skin and clothing when handling electrolyte.
- Do Not swallow electrolyte.
- In the event of an accident, flush with water and call a doctor immediately.

⚠ CAUTION

If the ignition is in the “ON” position there is potential for sparks and engagement of components. Sparks could cause an explosion or moving parts could accidentally engage causing personal injury.

Be sure ignition switch is in the “OFF” position before charging the battery.

- Keep all guards, shields and all safety devices in place and in safe working condition.
- Check all bolts frequently to maintain proper tightness.
- Frequently check for worn or deteriorating components that could create a hazard.

Safety

▲ WARNING

Removal or modification of original equipment, parts and/or accessories may alter the warranty, controllability, and safety of the machine.

Unauthorized modifications to the original equipment or failure to use original Exmark parts could lead to serious injury or death.

Unauthorized changes to the machine, engine, fuel or venting system, may violate applicable safety standards such as: ANSI, OSHA and NFPA and/or government regulations such as EPA and CARB.

- On slopes, the weight of the towed equipment may cause loss of traction, increased risk of rollover, and loss of control. Reduce the towed weight and slow down.
- Stopping distance increases with the weight of the towed load. Travel slowly and allow extra distance to stop.
- Make wide turns to keep the attachment clear of the machine.

▲ WARNING

Hydraulic fluid escaping under pressure can penetrate skin and cause injury. Fluid accidentally injected into the skin must be surgically removed within a few hours by a doctor familiar with this form of injury or gangrene may result.

- If equipped, make sure all hydraulic fluid hoses and lines are in good condition and all hydraulic connections and fittings are tight before applying pressure to hydraulic system.
- Keep body and hands away from pinhole leaks or nozzles that eject high pressure hydraulic fluid.
- Use cardboard or paper, not your hands, to find hydraulic leaks.
- Safely relieve all pressure in the hydraulic system by placing the motion control levers in neutral and shutting off the engine before performing any work on the hydraulic system.

Towing Safety

- Do not attach towed equipment except at the hitch point.
- Follow the attachment manufacturer's recommendation for weight limits for towed equipment and towing on slopes. Towed weight must not exceed the weight of the machine, operator, and ballast; otherwise hydrostatic transmission failure may occur. Use counterweights or wheel weights as described in the attachment manufacturer's manual.
- Never allow children or others in or on towed equipment.

Safety and Instructional Decals

- Keep all safety signs legible. Remove all grease, dirt and debris from safety signs and instructional labels.
- Replace all worn, damaged, or missing safety signs.
- When replacement components are installed, be sure that current safety signs are affixed to the replaced components.
- If an attachment or accessory has been installed, make sure current safety signs are visible.
- New safety signs may be obtained from your authorized Exmark equipment dealer or distributor or from Exmark Mfg. Co. Inc.
- Safety signs may be affixed by peeling off the backing to expose the adhesive surface. Apply only to a clean, dry surface. Smooth to remove any air bubbles.
- Familiarize yourself with the following safety signs and instruction labels. They are critical to the safe operation of your Exmark commercial mower.



106-5517

1. Warning—do not touch the hot surface.

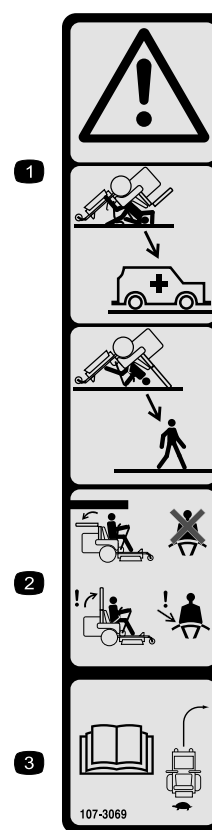

107-3069

1. Warning—there is no rollover protection when the roll bar is down.
2. To avoid injury or death from a rollover accident, keep the roll bar in the fully raised and locked position and wear the seat belt. Lower the roll bar only when absolutely necessary; do not wear the seat belt when the roll bar is down.
3. Read the Operator's manual; drive slowly and carefully.

Safety

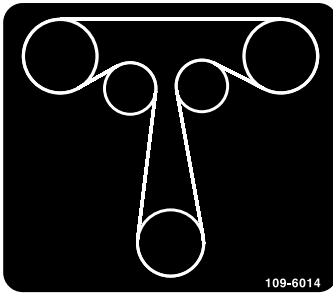

109-6014

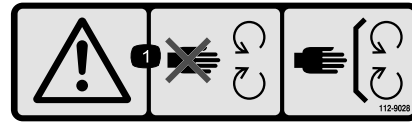

112-9028

1. Warning—stay away from moving parts; keep all guards in place.

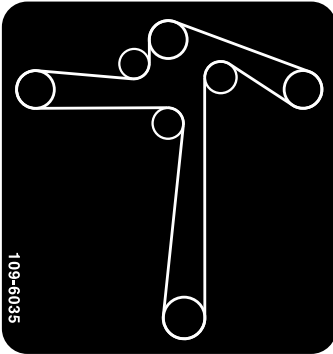

109-6035

109-6035

Side Discharge Units Only

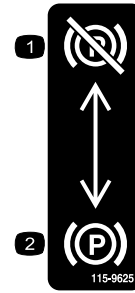

115-9625

1. Parking brake—disengaged
2. Parking brake—engaged

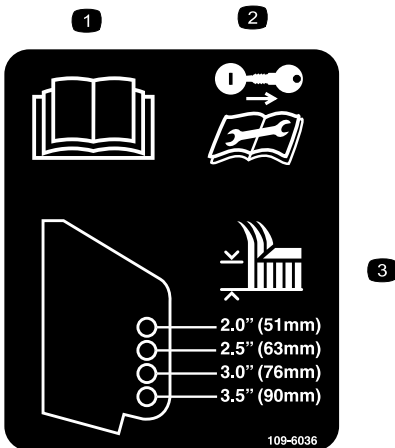

109-6036

1. Read the Operator's manual
2. Remove the ignition key and read the instructions before servicing or performing maintenance.
3. Height of cut
 - 2.0" (51mm)
 - 2.5" (63mm)
 - 3.0" (76mm)
 - 3.5" (90mm)

1

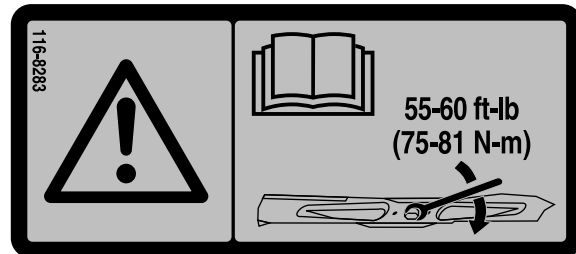

116-8283

1. Warning—read the Operator's Manual for instructions on torquing the blade bolt/nut to 55-60 ft-lb (75-81 N-m).

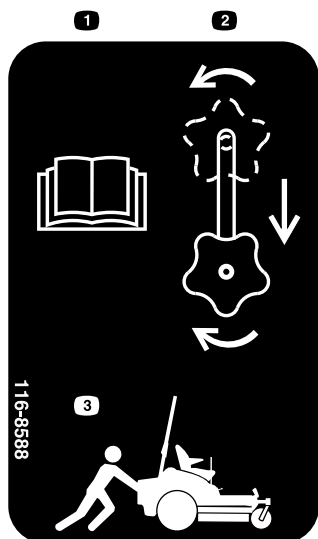

116-8588

1. Read the Operator's manual.
2. Rotate the drive release knob to loosen, slide the knob, and tighten.
3. Push the machine.

CALIFORNIA SPARK ARRESTER WARNING

Operation of this equipment may create sparks that can start fires around dry vegetation. A spark arrester may be required. The operator should contact local fire agencies for laws or regulations relating to fire prevention requirements. 117-2718

117-2718

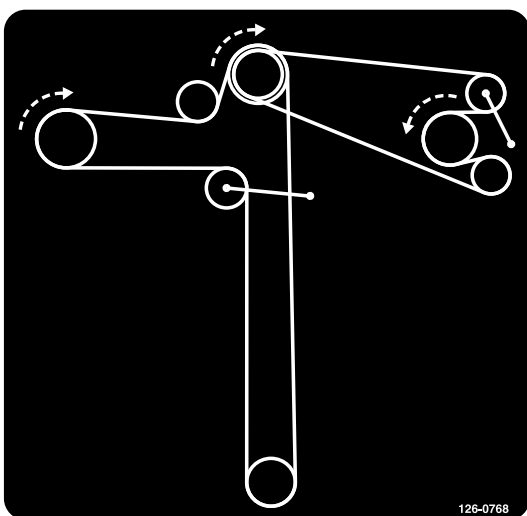

126-0768

Rear Discharge Units Only

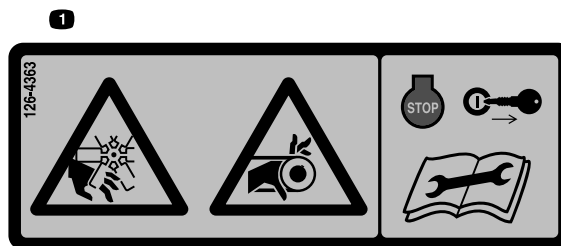

126-4363

1. Cutting/dismemberment hazard, fan and entanglement hazard, belt—Stop engine and remove key before adjusting, servicing or cleaning.

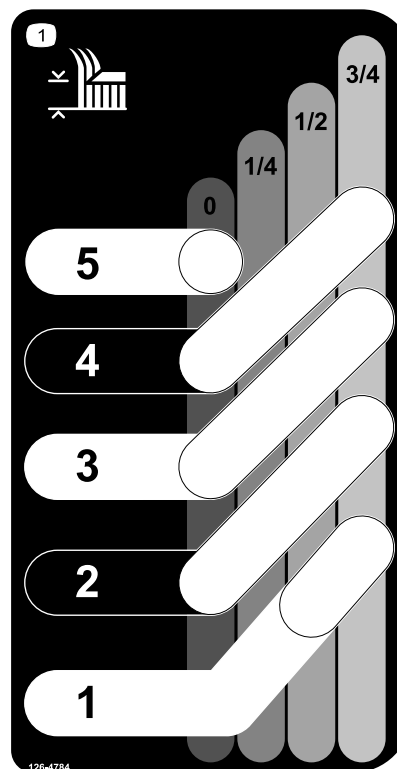

126-4784

1. Height of cut

Safety

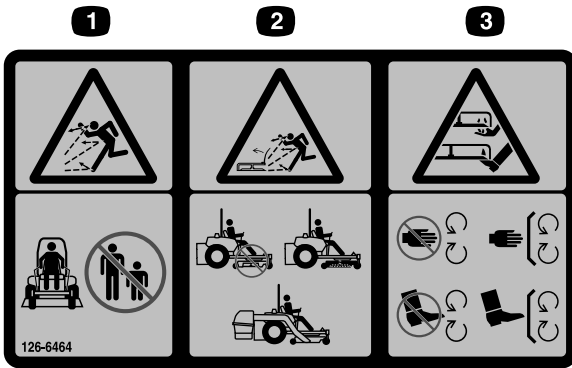

126-6464

Side Discharge Units

1. Thrown objects hazard - keep bystanders a safe distance from the machine
2. Thrown objects hazard, mower - do not operate without the deflector, discharge cover or grass collection system in place.
3. Cutting/dismemberment of hand or foot - stay away from moving parts; keep all guards and shields in place.

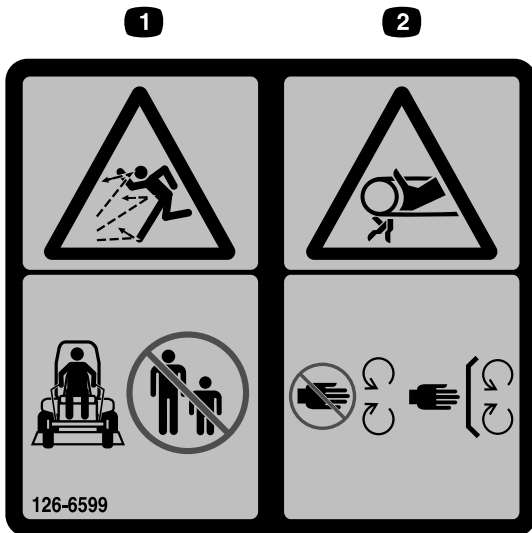

126-6599

Rear Discharge Units

1. Thrown objects hazard - keep bystanders a safe distance from the machine.
2. Cutting/dismemberment of hand - stay away from moving parts; keep all guards and shields in place.

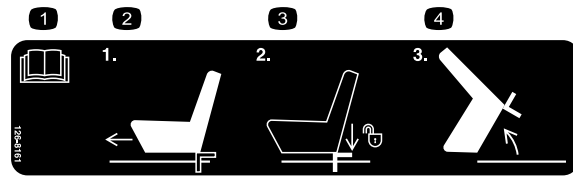

126-8161

X-Series Units

1. Read Operator's manual
2. Slide seat forward
3. Press down on latch to unlock seat
4. Rotate seat

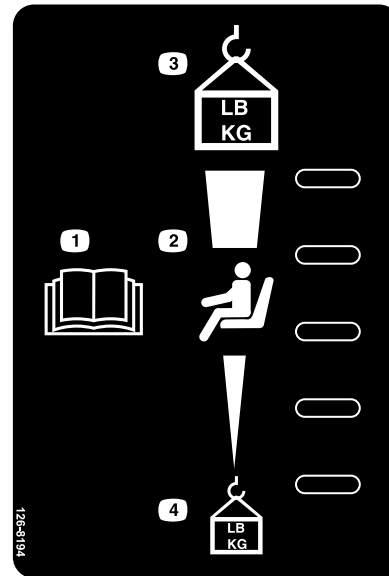

126-8194

S-Series Units

1. Read the Operator's manual
2. Seat adjustment
3. Firmest position/operator 200lb(91kg) and over
4. Softest position/operator less than 200lb(91kg)

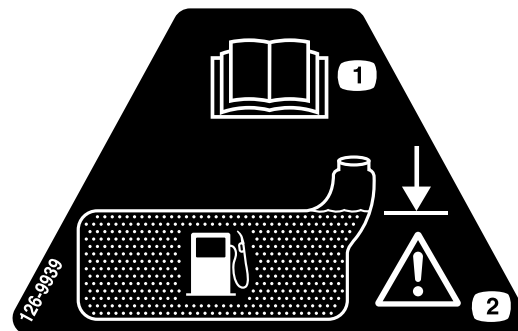

126-9939

1. Read the Operator's Manual
2. Fill to bottom of filler neck; warning—do not overfill the tank

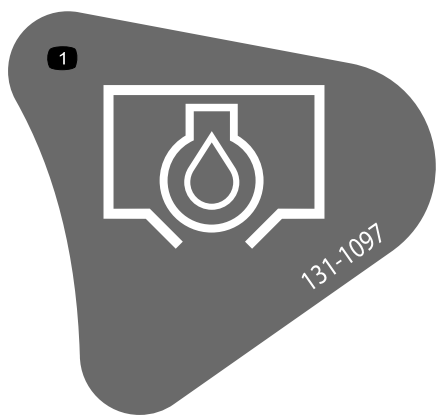

131-1097
Exmark 708cc Engine Only

1. Oil drain

**1 SHUT DOWN ENGINE AT FULL THROTTLE
COUPEZ LE MOTEUR À PLEIN RÉGIME**

Exmark 708cc Engine Only

1. Shut down engine at full throttle

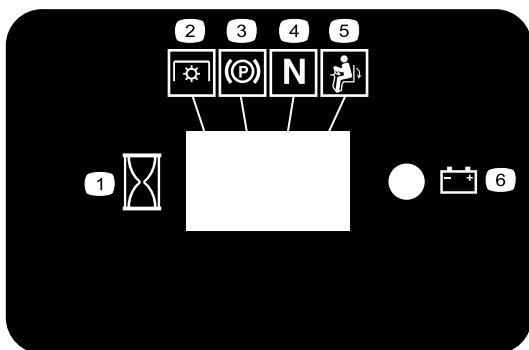

Message Display

- | | |
|------------------|-----------------------------|
| 1. Hour | 4. Neutral |
| 2. PTO | 5. Operator presence switch |
| 3. Parking brake | 6. Battery |

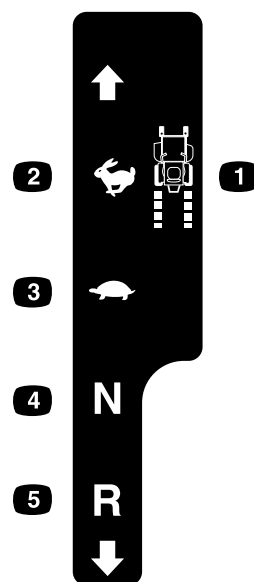

LH Motion Control

- | | |
|------------------|------------|
| 1. Machine speed | 4. Neutral |
| 2. Fast | 5. Reverse |
| 3. Slow | |

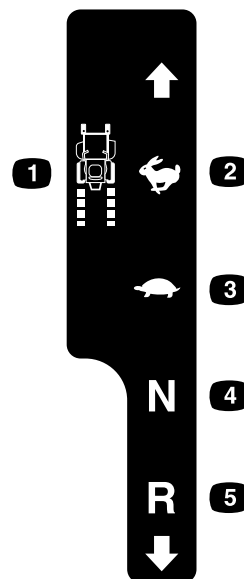

RH Motion Control

- | | |
|------------------|------------|
| 1. Machine speed | 4. Neutral |
| 2. Fast | 5. Reverse |
| 3. Slow | |

Safety

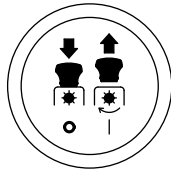

1 2

PTO Switch Symbols

1. PTO-disengage
 2. PTO-engage
-

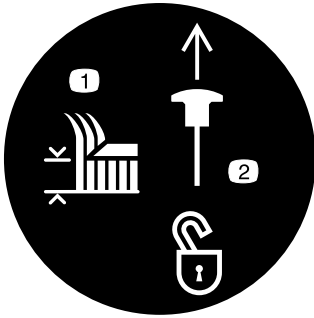

Transport Lock

1. Height of cut
 2. Pull up to unlock the transport lock
-

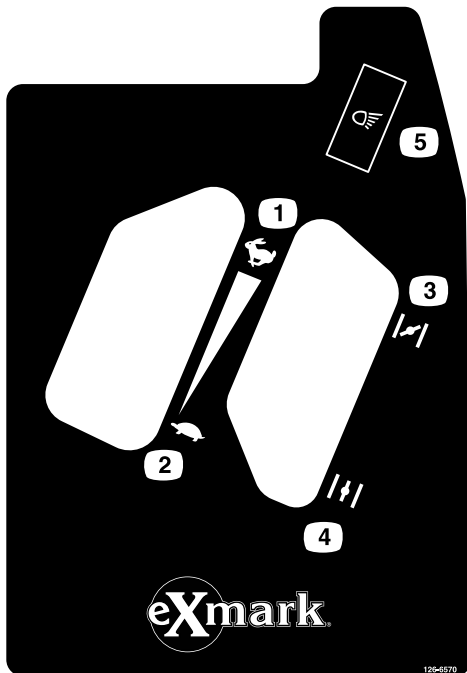

126-6570

1. Throttle-fast
 2. Throttle-slow
 3. Choke-on
 4. Choke-off
 5. Optional light accessory
-

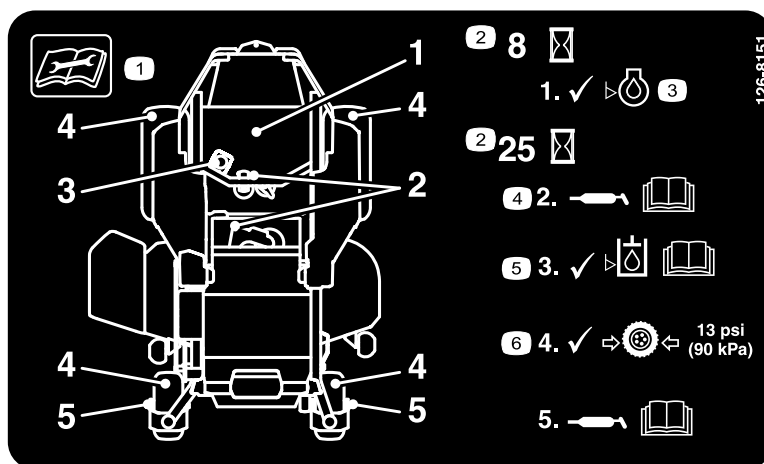

126-8151

1. Read the instructions before servicing or performing maintenance
2. Time interval
3. Check oil level
4. Refer to the Operator's manual for grease instructions
5. Check hydraulic oil level and refer to the Operator's manual or further instructions
6. Check tire pressure

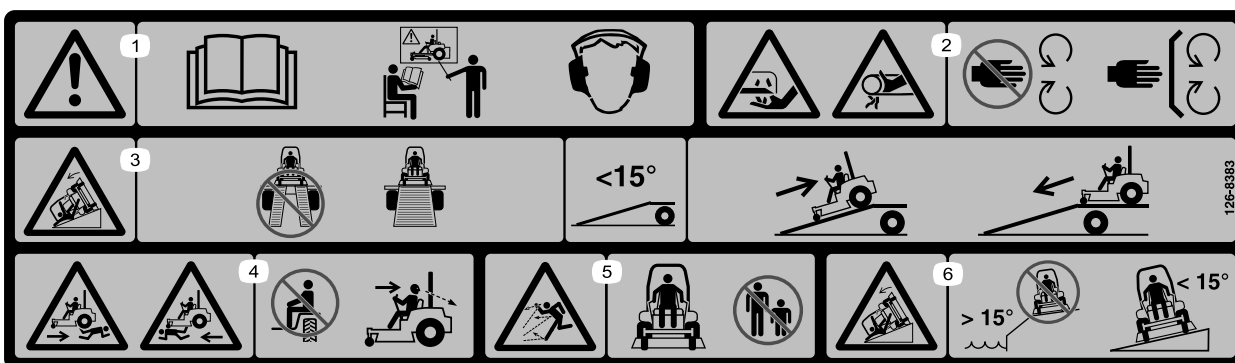

126-8383

1. Warning-Read the Operator's Manual. Do Not operate this machine unless you are trained. Wear hearing protection.
2. Cutting and pinching hazard - keep hands and feet away from moving parts; keep all guards and shields in place.
3. Ramp hazard - when loading onto a trailer, do not use dual ramps; only use a singular ramp wide enough for the machine and that has an incline less than 15 degrees; back up the ramp (in reverse) and drive forward off the ramp.
4. Bodily harm hazard - look behind you when mowing in reverse.
5. Thrown object hazard - keep bystanders away.
6. Tipping hazard on slopes - do not use on slopes near open water; do not use on slopes greater than 15 degrees.

Specifications

Systems

Engine

- Engine Specifications: See your Engine Owner's Manual
- Engine Oil Type: Exmark 4-Cycle Premium Engine Oil
- RPM:
 - **X- and S-Series:** Full Speed: 3750 ±50 RPM (PTO not engaged) Idle: 1500 ±100 RPM
 - **E-Series:** Full Speed: 3600 ±50 RPM (PTO not engaged) Idle: 1500 ±100 RPM

Fuel System

- Capacity: 7.0 gal. (26.5 L)
- Fuel Recommendations:
 - For best results, use only clean, fresh, unleaded gasoline with an octane rating of 87 or higher ((R+M)/2 rating method).
 - Oxygenated fuel with up to 10% ethanol or 15% MTBE by volume is acceptable.
 - **Do Not** use ethanol blends of gasoline (such as E15 or E85) with more than 10% ethanol by volume. Performance problems and/or engine damage may result which may not be covered under warranty.
 - **Do Not** use gasoline containing methanol.
 - **Do Not** store fuel either in the fuel tank or fuel containers over the winter unless a fuel stabilizer is used.
 - **Do Not** add oil to gasoline.
- Fuel Filter:
 - Kohler: Kohler P/N 24 050 13
 - Kawasaki: Kawasaki P/N 49019-0014
 - Exmark Engine: Exmark P/N 133-1563
- Fuel Shut-Off Valve:
 - All Units: 1/4 turn ("ON", "OFF").

Electrical System

- Charging System: Flywheel Alternator
- Charging Capacity: 15 amps
- Battery Type: BCI Group U1

- Recommended Minimum Battery CCA: 260 CCA
- Battery Voltage: 12 Volt
- Polarity: Negative Ground
- Fuses:
 - All units:
 - 20 amp charging system fuse (not used on Kohler engines)
 - 15 amp main fuse

Safety Interlock System

- LCD indicators appear for the PTO, park brake, drive levers, and operator presence in the message display on the RH control panel.
- PTO must be disengaged, brake engaged, and motion control levers out (neutral lock) to start engine. (It is not necessary for the operator to be in the seat to start the engine.)
- Operator must be in seat when PTO is engaged, brake is disengaged, or motion control levers are moved in or engine will stop.
- Engine will stop if either the left, the right, or both levers are moved from neutral lock position while brake is engaged.

Operator Controls

- Steering and Motion Control:

Note: Motion control levers are adjustable to three heights.

- Separate levers, on each side of the console, control speed and direction of travel of the respective drive wheels.
- Steering is controlled by varying the position of the levers relative to each other.
- Moving motion control levers outward (in slots) locks the drive system in neutral.
- PTO Engagement Switch: Engages electric clutch (to drive belt) which engages mower blades.
- Parking Brake Lever: Engages parking brake.
- Deck Height Adjustment Lever: Sets cutting height to desired position.
- Deck Lift Pedal: Foot pedal that lifts deck.
- Transport Lock: Latching position: Automatically latches at the transport position.

Seat

- Seat Type:
 - **X-Series:**
Deluxe suspension (adjustable spring suspension) seat with high back, molded foam flip-up armrests, and integral safety switch.
 - **S-Series:**
Standard seat with foam padded seat cushion with armrests, integral safety switch, and adjustable Seat Isolation System suspension for reduced vibration and enhanced ride.
 - **E-Series:**
Standard seat with foam padded seat cushion with armrests and integral safety switch.
- Mounting:
 - **X- and S-Series:** Hinged seat frame to tilt up seat. Adjustable fore and aft on seat tracks.
 - **E-Series:** Adjustable fore and aft on seat tracks.
- Armrests: Molded flip-up armrests.
- Seat Safety Switch: Integrated seat switch. Time delay seat switch eliminates rough ground cut-outs.

Hydrostatic Ground Drive System

- Two unitized hydrostatic transmissions:
 - **X-Series:**
Hydro Gear ZT3400
 - **S-Series:**
 - ◇ Units with side discharge decks:
Hydro Gear ZT3100
 - ◇ Units with rear discharge deck:
Hydro Gear ZT3400
 - **E-Series:**
 - ◇ Units with 48 or 52 inch decks:
Hydro Gear ZT2800
 - ◇ Units with 60 inch deck:
Hydro Gear ZT3100
- Hydraulic Oil Type: Exmark Premium Hydro Oil.

- Hydraulic Oil Capacity: 77 oz (2.3 L) per side
- Hydraulic Filter: P/N 109-3321
- Speeds:
 - **X-Series:**
 - ◇ Forward: 0-10 mph (16.1 km/hr) forward.
 - ◇ Reverse: 0-7 mph (11.3 km/hr) reverse.
 - **S-Series:**
 - ◇ Forward: 0-9 mph (14.5 km/hr) forward.
 - ◇ Reverse: 0-6 mph (9.7 km/hr) reverse.
 - **E-Series:**
 - ◇ Forward: 0-8 mph (12.9 km/hr)
 - ◇ Reverse: 0-5 mph (8.0 km/hr) reverse.
- Drive wheel release valves allow machine to be moved when engine is not running.

Tires & Wheels

X-Series:

	Drive	
	Pneumatic (Air filled)	
Deck Size	48 & 52	60
Quantity	2	2
Tread	K500	K500
Size	24 x 9.50-12	24 x 10.5-12
Ply Rating	4	4
Pressure	13 psi (90 kPa)	13 psi (90 kPa)

S-Series:

	Drive	
	Pneumatic (Air filled)	
Deck Size	48 & 52	60
Quantity	2	2
Tread	K500	K500
Size	23 x 9.50-12	23 x 10.50-12
Ply Rating	4	4
Pressure	13 psi (90 kPa)	13 psi (90 kPa)

Specifications

E-Series:

	Drive	
	Pneumatic (Air filled)	
Deck Size	48 & 52	60
Quantity	2	2
Tread	K500	K500
Size	22 x 9.50-12	22 x 10.50-12
Ply Rating	4	4
Pressure	13 psi (90 kPa)	13 psi (90 kPa)

Front Caster — All Models

	Pneumatic (Air filled)
Deck Size	All Models
Quantity	2
Tread	Smooth
Size	13 x 6.50-6
Ply Rating	4
Pressure	13 psi (90 kPa)

Cutting Deck

- Cutting Width:
 - 48 inch Deck: (121.9 cm)
 - 52 inch Deck: (132.1 cm)
 - 60 inch Deck: (152.4 cm)
- Discharge:
 - Side Discharge: Non “R” models
 - Rear Discharge: “R” models
- Blade Size:
 - 48 inch Deck: 16.25 inches (41.3 cm) – (3 ea.)
 - 52 inch Deck: 18.00 inches (45.7 cm) – (3 ea.)
 - 60 inch Deck: 20.50 inches (52.1 cm) – (3 ea.)
- Blade Spindles:
 - X-Series: Solid steel spindles with .98 inch (25 mm) I.D. bearings.
 - S- and E-Series: Solid steel spindles with .67 inch (17 mm) I.D. bearings.
- Deck Drive: “B” Section belt with self-tensioning idler.
- Electric clutch:
 - **48 & 52 Inch Decks:** 125 ft-lb Mag Stop
 - **60 Inch Deck:** 125 ft-lb Neo-Mag Stop
- Deck: Full floating deck is attached to out-front support frame. Anti-scalp rollers provide maximum turf protection. Deck design allows for bagging, mulching or side discharge.
 - 48 inch Deck: 3 anti-scalp rollers
 - 52 inch Deck: 5 anti-scalp rollers
 - 60 inch Deck: 5 anti-scalp rollers
 - 60 inch Deck-Rear Discharge: 4 anti-scalp rollers
 - Side Discharge: Full floating deck is attached to out-front support frame. Anti-scalp rollers provide maximum turf protection. Deck design allows for bagging, mulching or side discharge.
 - Rear Discharge: Full floating deck is attached to out-front support frame. Anti-scalp rollers and side bumpers provide maximum turf protection. Deck design allows for rear discharge or finish cut (reduced discharge).
- Deck Depth:
 - **S- and E-Series:**
 - ◇ Side Discharge: 5.0 inches (12.7 cm)
 - ◇ Rear Discharge: 5.5 inches (14.0 cm)
 - **X-Series:**
 - All Decks: 5.5 inches (14.0 cm)
- Cutting Height Adjustment:

Foot activated lever is used to adjust the cutting height from 1 1/2 inch (3.8 cm) to 5 inches (12.7 cm) in 1/4 inch (6.4 mm) increments.
- Mulching Kit: Optional.

Dimensions

Overall Width:

X-Series—Side Discharge Units:

	48 inch Deck	52 inch Deck	60 inch Deck
Without Deck	47.4 inches (120.4 cm)	48.7 inches (123.7 cm)	52.1 inches (132.3 cm)
Deflector Up	52.6 inches (133.6 cm)	57.3 inches (145.5 cm)	61.7 inches (156.7 cm)
Deflector Down	59.5 inches (151.1 cm)	64.6 inches (164.1 cm)	72.7 inches (184.7 cm)

S-Series—Side Discharge Units:

	48 inch Deck	52 inch Deck	60 inch Deck
Without Deck	47.2 inches (119.9 cm)	48.5 inches (123.2 cm)	51.4 inches (130.6 cm)
Deflector Up	52.6 inches (133.6 cm)	57.3 inches (145.5 cm)	61.7 inches (156.7 cm)
Deflector Down	59.5 inches (151.1 cm)	64.3 inches (163.3 cm)	72.3 inches (183.6 cm)

E-Series—Side Discharge Units:

	48 inch Deck	52 inch Deck	60 inch Deck
Without Deck	46.7 inches (118.6 cm)	48.0 inches (121.9 cm)	51.2 inches (130.0 cm)
Deflector Up	52.6 inches (133.6 cm)	57.3 inches (145.5 cm)	61.7 inches (156.7 cm)
Deflector Down	59.5 inches (151.1 cm)	64.3 inches (163.3 cm)	72.3 inches (183.6 cm)

Rear Discharge Units:

	60 inch Deck
Without Deck	51.4 inches (130.6 cm)
With Deck	66.0 inches (167.6 cm)

Overall Length:

Side Discharge Units:

48 inch Deck	52 inch Deck	60 inch Deck
81.7 inches (207.5 cm)	81.7 inches (207.5 cm)	82.2 inches (208.8 cm)

Rear Discharge Units:

60 inch Deck
84.3 inches (214.1 cm)

Overall Height:

X-Series—Side Discharge Units

Roll Bar - Up	Roll Bar - Down
70.4 inches (178.8 cm)	48.4 inches (122.9 cm)

S-Series—Side Discharge Units

Roll Bar - Up	Roll Bar - Down
70.2 inches (178.3 cm)	48.9 inches (124.2 cm)

E-Series—Side Discharge Units

Roll Bar - Up	Roll Bar - Down
69.7 inches (177.0 cm)	47.0 inches (119.4 cm)

Rear Discharge Units

Roll Bar - Up	Roll Bar - Down
70.2 inches (178.3 cm)	48.9 inches (124.2 cm)

Specifications

Tread Width: (Center to Center of Tires, Widthwise)

X-Series—Side Discharge Units

	48 inch Deck	52 inch Deck	60 inch Deck
Drive Wheels	37.7 inches (95.8 cm)	39.0 inches (99.1 cm)	40.7 inches (103.4 cm)
Caster Wheels	33.1 inches (84.1 cm)	33.1 inches (84.1 cm)	38.2 inches (97.0 cm)

S-Series—Side Discharge Units

	48 inch Deck	52 inch Deck	60 inch Deck
Drive Wheels	37.7 inches (95.8 cm)	39.0 inches (99.1 cm)	40.7 inches (103.4 cm)
Caster Wheels	33.1 inches (84.1 cm)	33.1 inches (84.1 cm)	38.2 inches (97.0 cm)

E-Series—Side Discharge Units

	48 inch Deck	52 inch Deck	60 inch Deck
Drive Wheels	37.7 inches (95.8 cm)	39.0 inches (99.1 cm)	40.7 inches (103.4 cm)
Caster Wheels	33.1 inches (84.1 cm)	33.1 inches (84.1 cm)	38.2 inches (97.0 cm)

Rear Discharge Units:

	60 inch Deck
Drive Wheels	40.7 inches (103.4 cm)
Caster Wheels	31.0 inches (78.7 cm)

Wheel Base: (Center of Caster Tire to Center of Drive Tire)

Side Discharge Units:

48 inch Deck	52 inch Deck	60 inch Deck
49.7 inches (126.2 cm)	49.7 inches (126.2 cm)	50.2 inches (127.5 cm)

Rear Discharge Units:

60 inch Deck
52.3 inches (132.8 cm)

Curb Weight:

Units with 48 Inch Side Discharge Decks	849-937 lb (385-425 kg)
Units with 52 Inch Side Discharge Decks	862-957 lb (391-434 kg)
Units with 60 Inch Side Discharge Decks	901-1006 lb (409-456 kg)
Units with 60 Inch Rear Discharge Decks	1012 lb (459 kg)

Torque Requirements

Bolt Location	Torque
X-Series: Blade Drive Sheave Mounting Nut	130-160 ft-lb (176-217 N-m)
S- and E-Series: Blade Drive Sheave Mounting Nut	75-85 ft-lb (102-115 N-m)
Blade Mounting Bolt (lubricate with anti-seize)	50-60 ft-lb (68-81 N-m)
Anti-Scalp Roller Nyloc Nut — Side Discharge Units Only (See Figure 18)	50-55 ft-lb (68-75 N-m)
Anti-Scalp Roller Nyloc Nut — Rear Discharge Units Only (See Figure 19)	30-35 ft-lb (41-47 N-m)
Engine Mounting Bolts	27-33 ft-lb (37-45 N-m)
Wheel Lug Nuts	90-100 ft-lb (122-136 N-m)
Rollover Protection System (Roll Bar) 1/2 inch Mounting Bolts	90-100 ft-lb (122-136 N-m)
Clutch Retaining Bolt (secured with threadlocker)	49-61 ft-lb (66-83 N-m)
Rear Discharge Side Bumpers	10-12 ft-lb (14-16 N-m)

Product Overview

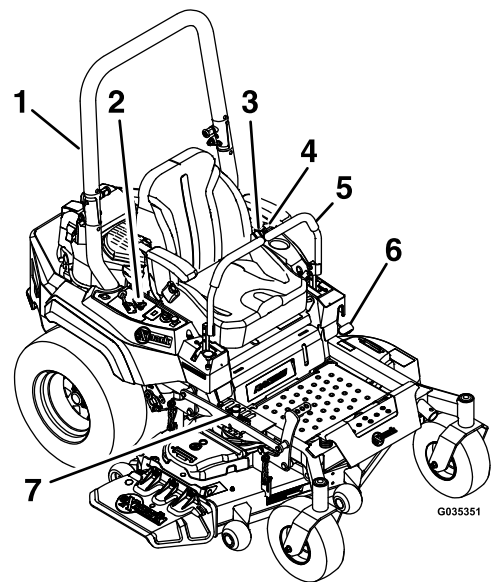

Figure 4

- | | |
|--------------------------------------|-----------------------------|
| 1. Rollover Protection System (ROPS) | 5. Motion control levers |
| 2. Engine Controls (right console) | 6. Parking brake |
| 3. Seat belt | 7. Height of cut adjustment |
| 4. Fuel cap | |

Operation

Operation

Note: Determine the left and right sides of the machine from the normal operating position.

Controls

Motion Control Levers

The motion control levers are located on each side of the console and control the forward and reverse motion of the machine.

Moving the levers forward or backward turns the wheel on the same side forward or reverse respectively. Wheel speed is proportional to the amount the lever is moved.

Moving the levers outward from the center position into the T-slot locks them in the neutral position (Figure 5).

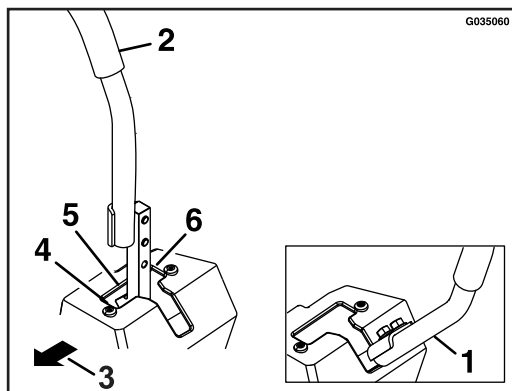
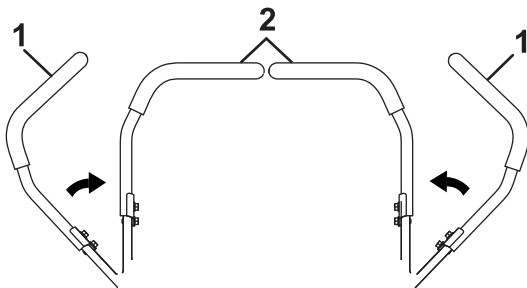

Figure 5

- | | |
|--|----------------------|
| 1. Neutral lock position (handles out) | 4. Forward |
| 2. Neutral operate position (handles in) | 5. Neutral (operate) |
| 3. Front of unit | 6. Reverse |

Choke Control

Located on right console (black lever) (see Figure 6).

The choke is used to aid in starting a cold engine. Moving the choke lever forward will put the choke in the “ON” position and moving the choke lever to the rear, to the detent, will put the choke in the “OFF” position. Do Not run a warm engine with choke in the “ON” position.

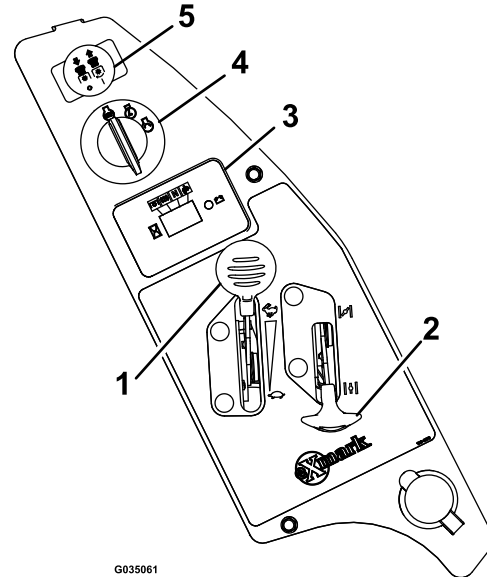

Figure 6

- | | |
|-------------------|--|
| 1. Throttle lever | 4. Ignition switch |
| 2. Choke lever | 5. Blade control switch (power take-off) |
| 3. Hour meter | |

Throttle Control

Located on right console (red lever) (see Figure 6).

The throttle is used to control engine speed. Moving the throttle lever forward will increase engine speed and moving the throttle lever to the rear will decrease engine speed. Moving the throttle forward into the detent is full throttle.

Brake Lever

Located on left side of unit, just to the front of the LH motion control lever.

The brake lever engages a parking brake on the drive wheels.

Pull the lever up and rearward to engage the brake.

Push the lever forward and down to disengage the brake.

The unit must be tied down and brake engaged when transporting.

Ignition Switch

Located on right console (see Figure 6).

The ignition switch is used to start and stop the engine. The switch has three positions “OFF”, “ON” and “START”. Insert key into switch and rotate clockwise to the “ON” position. Rotate clockwise to the next position to engage the starter (key must be held against spring pressure in this position). Allow the key to return to the “ON” position immediately after the engine starts.

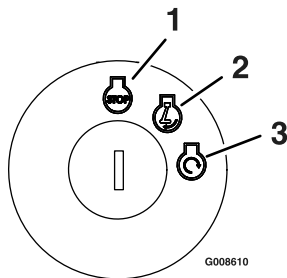

Figure 7

1. Off
2. On
3. Start

Note: Brake must be engaged, motion control levers out (neutral lock position) and PTO switch disengaged to start engine. (It is not necessary for the operator to be in the seat to start the engine.)

Hour Meter

Located on the control panel (see Figure 6 and Figure 8).

The hour meter records the number of hours that the engine has run.

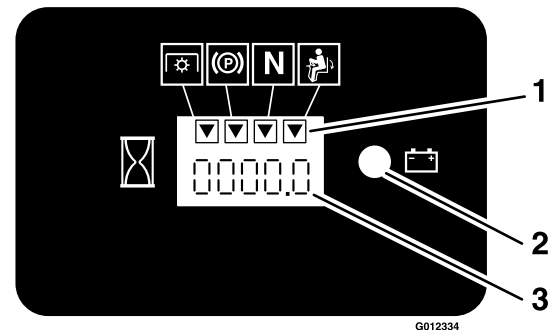

Figure 8

1. LCD indicators
2. Low voltage indicator light
3. Hour/Voltage display

Fuel Shut-Off Valve

Located by the lower LH ROPS tube mounting.

The fuel shut-off valve is used to shut off the fuel when the machine will not be used for a few days, during transport to and from the jobsite, and when parked inside a building.

Align valve handle with the fuel line to open. Rotate 90° to close.

Drive Wheel Release Valves

⚠ WARNING

Hands may become entangled in the rotating drive components below the engine deck, which could result in serious injury or death.

Stop engine, remove key, allow all the moving parts to stop before accessing the drive wheel release valves.

⚠ WARNING

The engine and hydraulic drive units can become very hot. Touching a hot engine or hydraulic drive units can cause severe burns.

Allow the engine and hydraulic drive units to cool completely before accessing the drive wheel release valves.

Located on the left and right sides underneath the engine deck.

During normal operating conditions, the drive wheel release valves are positioned in front of the slots. If

Operation

the machine has to be pushed by hand, the valves must be in the “released” position (see Figure 9).

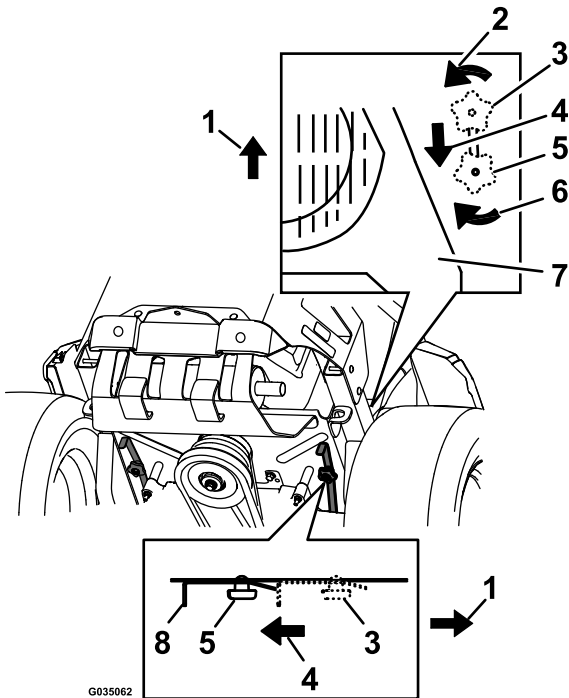

Figure 9

1. Front of the machine
2. Rotate bypass release knob counterclockwise to loosen
3. Lever position for operating the machine
4. Pull lever in this direction to push the machine
5. Lever position for pushing the machine
6. Rotate bypass release knob clockwise to tighten
7. Engine
8. Release lever

To release the drive system (see item 1 in Figure 9), loosen the knob by turning counterclockwise. Then pull the release lever on the underside of machine towards the back of the machine and retighten the knob to hold the release lever back in the released state. Repeat this on each side of the machine.

Release the parking brake. The machine is now able to be pushed by hand.

To reset the drive system (see item 2 in Figure 9), loosen the knob by turning counterclockwise. Then push the release lever on the underside of machine towards the front of the machine and retighten the knob to hold the release lever in the operating state. Repeat this on each side of the machine.

Do Not tow machine.

PTO Engagement Switch

Located on right console (see Figure 6).

Switch must be pulled out (up) to engage the blades. Switch is pushed in to disengage the blades.

Deck Lift Pedal

Located at the right front corner of the floor pan.

Push the pedal forward with your foot to raise the cutting deck. Allow the pedal to move rearward to lower the cutting deck to the cut height that has been set.

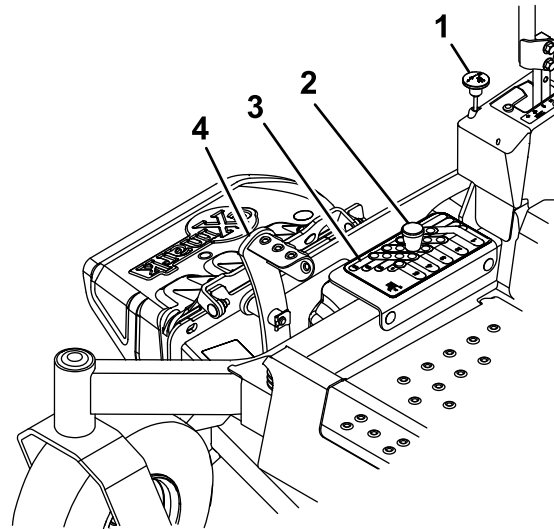

Figure 10

- | | |
|--------------------------|------------------------|
| 1. Transport lock knob | 3. Height of cut decal |
| 2. Height adjustment pin | 4. Deck foot pedal |

Transport Lock

Located on RH console in front of the motion control lever (see Figure 10).

The transport latching mechanism will automatically engage when the deck is raised to the transport position. To release the deck from the transport position: push the foot pedal to remove the load from the transport latching mechanism, pull up on the transport lock knob, and let the pedal come back to lower the deck down to the desired cut height.

Pre-Start

Fill fuel tank on level ground. See **Fuel Recommendations** in the Specifications section for additional gasoline information.

Do Not add oil to gasoline.

Do Not overfill fuel tank. Fill the fuel tank to the bottom of the filler neck. The empty space in the tank allows gasoline to expand. Overfilling may result in fuel leakage or damage to the engine or emission system.

Make sure you understand the controls, their locations, their functions, and their safety requirements.

Refer to the Maintenance section and perform all the necessary inspection and maintenance steps.

Operating Instructions

Raise the Rollover Protection System (ROPS)

Important: The roll bar is an integral and effective safety device. Keep the roll bar in the raised and locked position when operating the mower. Lower the roll bar temporarily only when absolutely necessary.

1. The knob must be completely latched with the tabs interlocking as shown in Figure 11 to lock the roll bar in the raised, operate position.
2. Apply forward pressure to the upper hoop of the roll bar.
3. Pull the knob and rotate 90° to hold in the unlatched position to lower the roll bar.
4. To return to the operate position, raise the roll bar, and then rotate knobs 90° so that the tabs interlock partially. Apply forward pressure to the roll bar upper hoop and observe that the knobs return to the completely latched position.

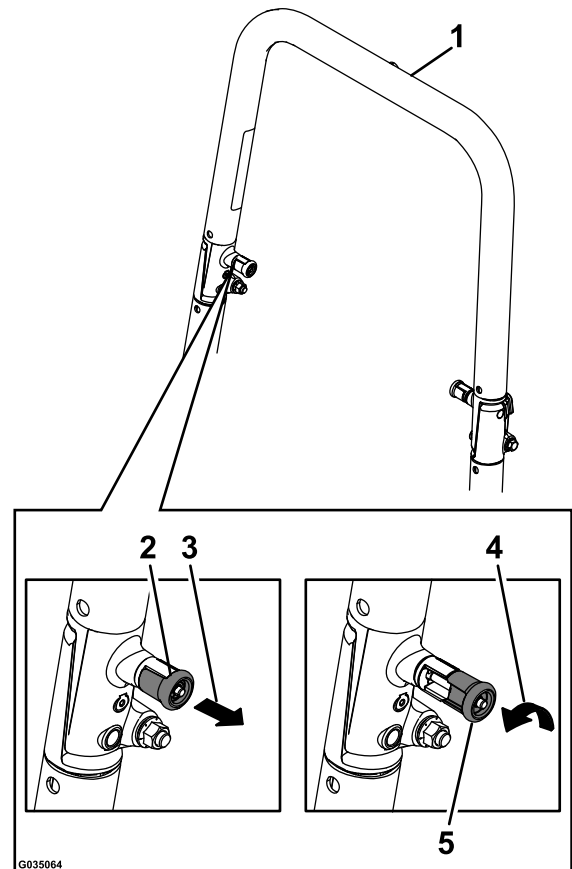

Figure 11

1. Roll bar upper hoop
2. Knob in "latched" position
3. Pull knob to unlatch
4. Rotate 90° to hold unlatched
5. Knob in "unlatched" position

5. Make sure the knobs are fully engaged with the roll bar in the raised position. The upper hoop of the roll bar may need to be pushed forward or pulled rearward to get both knobs fully engaged (see Figure 12).

Operation

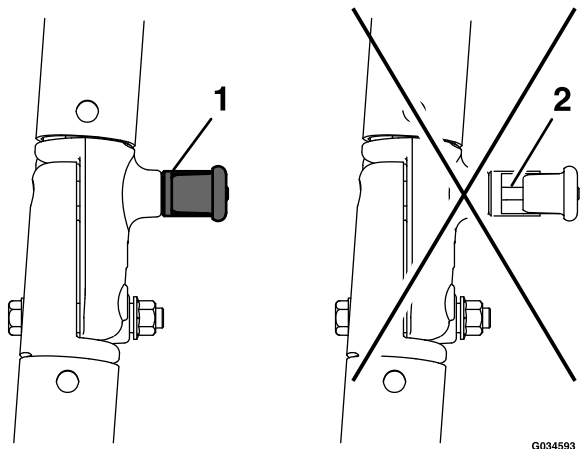

Figure 12

1. Engaged
2. Partially engaged — Do Not operate with ROPS in this condition.

Important: Always use the seat belt with the roll bar in the operate (raised) position. Ensure that the rear part of the seat is secured with the seat latch.

Open the Fuel Shut-Off Valve

Rotate the valve and align with the fuel line to open.

Starting the Engine

1. Move the motion control levers out to the neutral lock position.
2. Pull up and back on the parking brake lever to engage the parking brake.
3. Push down on the PTO switch to the “disengage” position.

Note: It is not necessary for the operator to be in the seat to start the engine.

4. Place the throttle midway between the “SLOW” and “FAST” positions.
5. On a cold engine, push the choke lever forward into the “ON” position.

On a warm engine, leave the choke in the “OFF” position.

6. Turn ignition switch to the “START” position. Release the switch as soon as the engine starts.

Important: Do Not crank the engine continuously for more than ten seconds at a time. If the engine does not start, allow a 60 second cool-down period between starting

attempts. Failure to follow these guidelines can burn out the starter motor.

7. If the choke is in the “ON” position, gradually return choke to the “OFF” position as the engine warms up.

Engaging the PTO

⚠ DANGER

The rotating blades under the mower deck are dangerous. Blade contact can cause serious injury or kill you.

Do Not put hands or feet under the mower or mower deck when the blades are engaged.

⚠ DANGER

An uncovered discharge opening will allow objects to be thrown in an operator’s or bystander’s direction. Also, contact with the blade could occur. Thrown objects or blade contact can cause serious injury or death.

Never operate the mower with the discharge deflector raised, removed, or altered unless there is a grass collection system or mulch kit in place and working properly.

The PTO push-pull switch engages the cutting blades. Be sure that all persons are clear of the mower deck and discharge area before engaging PTO.

Important: Operator must be in seat before the PTO can be engaged.

1. Set the throttle midway between the “SLOW” and “FAST” positions.
2. Pull the PTO switch outward to engage the blades.
3. Place the throttle in the “FAST” position to begin mowing.

Disengaging the PTO

1. Set the throttle midway between the “SLOW” and “FAST” positions.
2. Push the PTO switch in to disengage the blades.

Stopping the Engine

1. Bring the unit to a full stop.

2. Move the motion control levers out to the neutral lock position.
3. Engage the parking brake.
4. Place the throttle midway between the “SLOW” and “FAST” positions.
5. Disengage the PTO.
6. Allow the engine to run for a minimum of 15 seconds, then turn the ignition switch to the “OFF” position to stop the engine.
7. Remove the key to prevent children or other unauthorized persons from starting engine.
8. Close the fuel shut-off valve when the machine will not be in use for a few days, when transporting, or when the unit is parked inside a building.

Driving the Machine

⚠ CAUTION

Machine can spin very rapidly by positioning one lever too much ahead of the other. Operator may lose control of the machine, which may cause damage to the machine or injury.

- Use caution when making turns.
- Slow the machine down before making sharp turns.

Important: To begin movement (forward or backward) the operator must be in the seat, the brake lever must be disengaged (pushed down) before the motion control levers can be moved in or the engine will stop.

When the motion control levers are positioned fully outward (apart) in the T-slot, the drive system is in the neutral lock position (Figure 12).

When the motion control levers are moved directly inward (together) the drive system is in the neutral operate position.

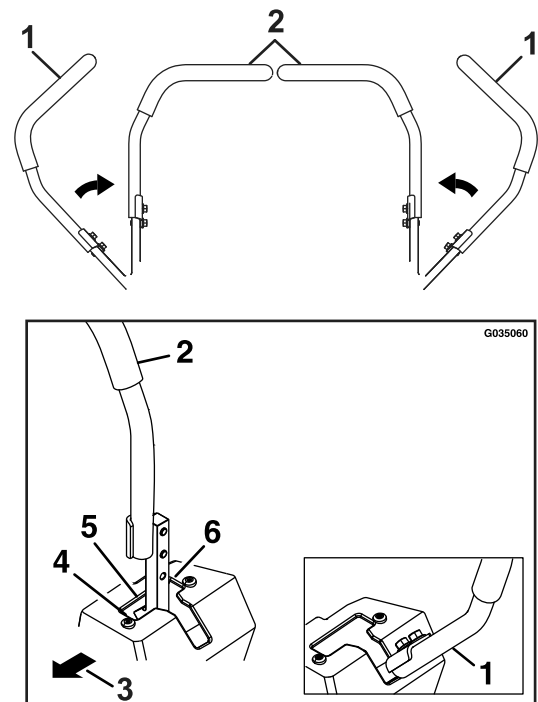

Figure 13

- | | |
|--|----------------------|
| 1. Neutral lock position (handles out) | 4. Forward |
| 2. Neutral operate position (handles in) | 5. Neutral (operate) |
| 3. Front of Unit | 6. Reverse |

Driving Forward

1. Release the parking brake.
2. Move the motion control levers inward to the center to the neutral position.
3. To move forward in a straight line, move both levers forward with equal pressure.

Operation

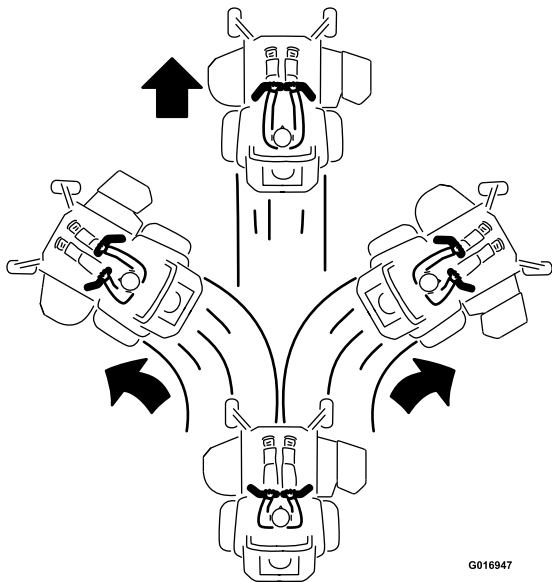

Figure 14

G016947

To turn left or right, pull the motion control lever back toward neutral in the desired turn direction.

The machine will move faster the farther the motion control levers are moved from the neutral position.

4. To stop, position both motion control levers in the neutral operate position.

Driving in Reverse

1. Move the motion control levers inward to the neutral operate position.
2. To move rearward in a straight line, move both levers rearward with equal pressure.

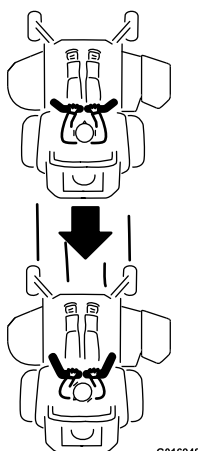

Figure 15

G016948

To turn right, release pressure on the RH motion control lever and the rear of the machine will move towards the rear and to the right.

To turn left, release pressure on the LH motion control lever and the rear of the machine will move towards the rear and to the left.

3. To stop, position both motion control levers in the neutral operate position.

Adjusting the Cutting Height

The cutting height of the mower deck is adjusted from 1 1/2 to 5 inches (3.8 cm to 12.7 cm) in 1/4 inch (6.4 mm) increments.

1. Stop the machine and move the motion control levers outward to the neutral locked position.
2. Disengage the PTO.
3. Raise and lock the deck to the transport position (Figure 16).

The deck is raised by pushing the foot operated deck lift pedal forward. The pedal is located at the front right corner of the floor pan.

Note: When changing the cutting height positions, always come to a complete stop and disengage the PTO.

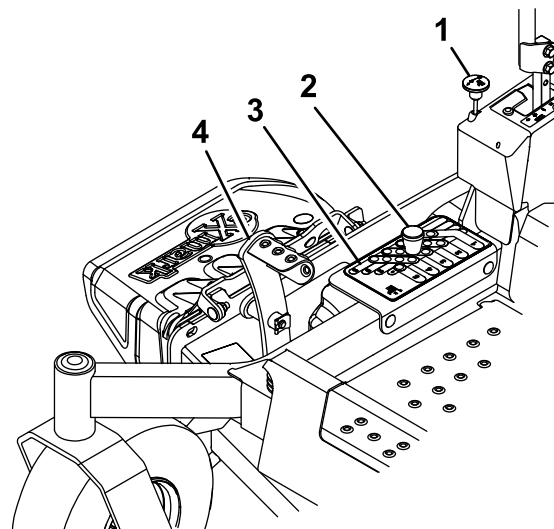

Figure 16

G035063

1. Transport lock knob
2. Height adjustment pin
3. Height of cut decal
4. Deck foot pedal

4. Insert the height adjustment pin into the hole corresponding to the desired cutting height.

See the decal on the top of the deck lift plate for cut heights.

5. Push the foot lever forward, pull up on the transport lock knob and let the deck lower down to the predetermined cut height by slowly decreasing foot pressure allowing the foot lever to travel rearward.

Adjusting the Anti-Scalp Rollers

It is recommended to change the anti-scalp roller position, when the height of cut has changed.

1. Stop the machine and move the motion control levers outward to the neutral locked position.
2. Disengage the PTO.
3. Engage the park brake.
4. Stop the engine, remove the key and wait for all moving parts to stop.
5. After adjusting the height of cut, adjust the anti-scalp rollers by removing the mounting hardware.
6. Place the rollers in one of the positions shown (Figure 17). Rollers will maintain 3/4 inch (19 mm) clearance to the ground to minimize gouging and roller wear or damage.

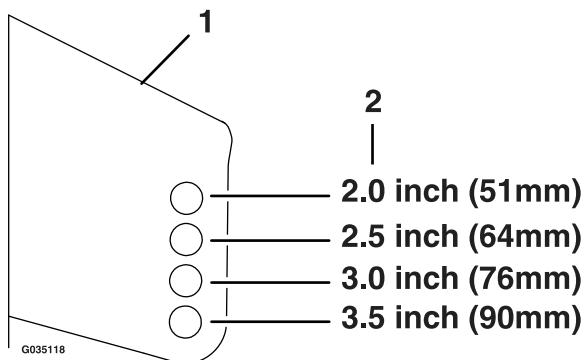

Figure 17

For cutting heights above 3.5 inches (90 mm) use the bottom hole. The rollers will still be effective against scalping.

1. Anti-scalp roller mounting bracket
2. Cutting height

For Maximum Deck Flotation, place the rollers one hole position lower. Rollers should maintain 1/4 inch (6.4 mm) clearance to the ground. **Do Not** adjust the rollers to support the deck.

7. Reinstall the mounting hardware.

• Side Discharge Units:

- A. Be sure the roller bolts are installed with the spring disc washer between the head of the bolt and the mounting bracket (see Figure 18).
- B. Torque the 3/8 nyloc nut to 50–55 ft-lb (68-75 N-m).

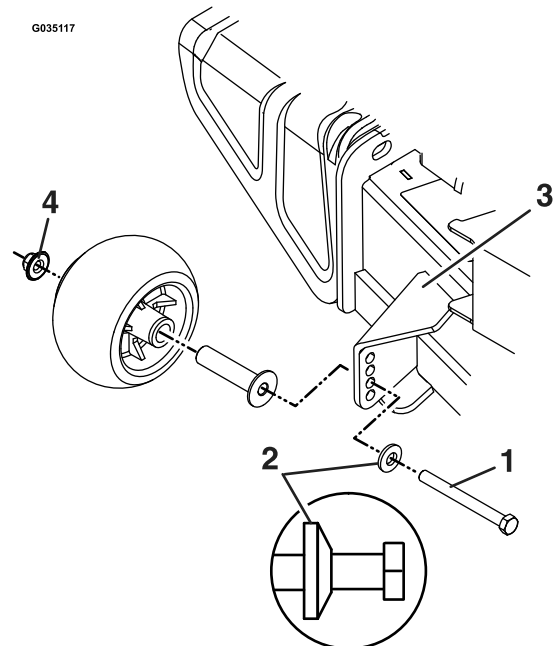

Figure 18

1. 3/8-16 X 3 3/4 inch Grade 8 bolt
2. Spring disc washer
3. Front right anti-scalp bracket shown
4. 3/8 inch nyloc-torque to 50-55 ft-lb (68-75 N-m)

Operation

• Rear Discharge Units:

Torque the 3/8 nyloc nut to 30-35 ft-lb (41-47 N-m) (see Figure 19).

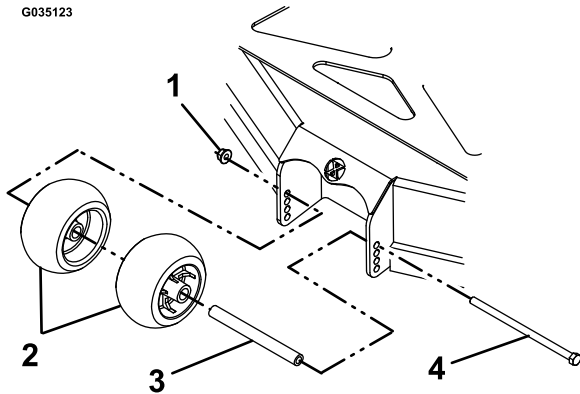

Figure 19

- | | |
|---|-----------------------------|
| 1. 3/8 inch nyloc-torque to 50-55 ft-lb (68-75 N-m) | 3. Wheel spacer |
| 2. Anti-scalp rollers | 4. 3/8-16 X 7 3/8 inch bolt |

Note: The foot operated deck lift assist lever can be used to momentarily lift the deck to clear objects. Be sure that PTO is disengaged.

Adjusting the Side Bumpers (Rear Discharge Units Only)

Mount the side bumpers in the top holes when operating in height of cuts higher than 2 1/2 inches (64 mm) and in the center holes when operating in height of cuts lower than 2 1/2 inches (64 mm).

Note: When bumpers become worn, switch the bumpers to the opposite sides of the mower, flipping them over. This allows the bumpers to be used longer before replacing them.

1. Stop the machine and move the motion control levers outward to the neutral locked position.
2. Disengage the PTO.
3. Engage the park brake.
4. Stop the engine, remove the key and wait for all moving parts to stop.
5. Position the transport lock in the latching position.
6. Remove the bolts and nuts from each bumper.

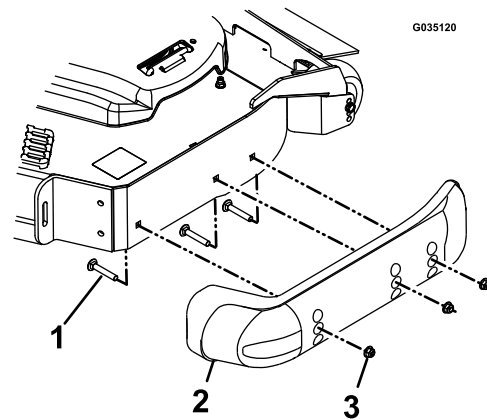

Figure 20

- | | |
|-----------|--------|
| 1. Bolt | 3. Nut |
| 2. Bumper | |

7. Move each bumper to the desired position and secure them with the bolts and nuts.

Note: Only use the top or center sets of holes to adjust the bumpers. The bottom holes are used when switching sides, at which time they become the top holes on the other side of the mower.

Transporting

Transporting the Machine

Use a heavy-duty trailer or truck to transport the machine. Ensure that the trailer or truck has all necessary lighting and marking as required by law. Thoroughly read all of the safety instructions. Knowing this information could help you, your family, pets, or bystanders avoid injury.

To transport the machine:

- Lock the brake and block the wheels.
- Be sure the fuel shut-off valve is closed.
- Securely fasten the machine to the trailer or truck with straps, chains, cable, or ropes. Only use the four designated tie-down locations on the mower—two on the left side and two on the right (see Figure 21). Use these locations even when transporting the mower with an attached accessory. Using non-designated locations may cause damage to the mower and/or attachment.

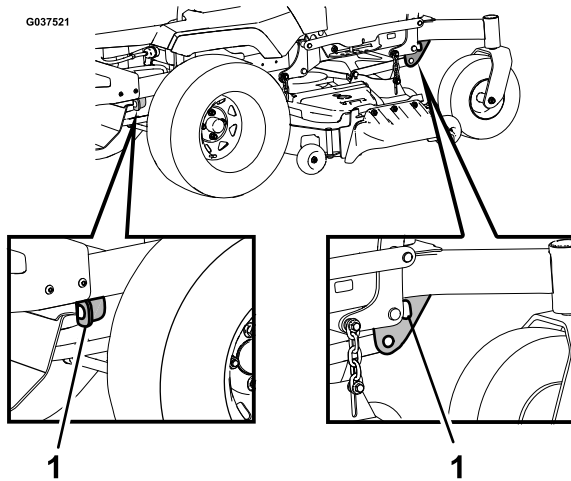

Figure 21
Right side shown

1. Tie-down location

- Secure a trailer to the towing vehicle with safety chains.

⚠ WARNING

Driving on the street or roadway without turn signals, lights, reflective markings, or a slow moving vehicle emblem is dangerous and can lead to accidents causing personal injury.

Do not drive machine on a public street or roadway.

Loading the Machine

Use extreme caution when loading or unloading machines onto a trailer or a truck. Use a full-width ramp that is wider than the machine for this procedure. Back up ramps and drive forward down ramps (Figure 22).

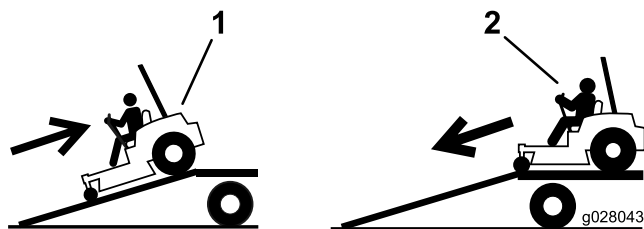

Figure 22

1. Back up ramps

2. Drive forward down ramps

Ensure the ramp is long enough so that the angle with the ground does not exceed 15 degrees (Figure 23).

On flat ground, this requires a ramp to be at least four times (4X) as long as the height of the trailer or truck bed to the ground. A steeper angle may cause mower components to get caught as the unit moves from the ramp to the trailer or truck. Steeper angles may also cause the machine to tip or lose control. If loading on or near a slope, position the trailer or truck so that it is on the down side of the slope and the ramp extends up the slope. This will minimize the ramp angle.

⚠ WARNING

Loading a machine onto a trailer or truck increases the possibility of tip-over and could cause serious injury or death.

- Use extreme caution when operating a machine on a ramp.
- Ensure that the ROPS is in the up position and use the seat belt when loading or unloading the machine. Ensure that the ROPS will clear the top of an enclosed trailer.
- Use only a full-width ramp; do not use individual ramps for each side of the machine.
- Do not exceed a 15-degree angle between the ramp and the ground or between the ramp and the trailer or truck.
- Ensure the length of ramp is at least four times (4X) as long as the height of the trailer or truck bed to the ground. This will ensure that ramp angle does not exceed 15 degrees on flat ground.
- Back up ramps and drive forward down ramps.
- Avoid sudden acceleration or deceleration while driving the machine on a ramp as this could cause a loss of control or a tip-over situation.

Important: Do not use narrow individual ramps for each side of the machine.

Operation

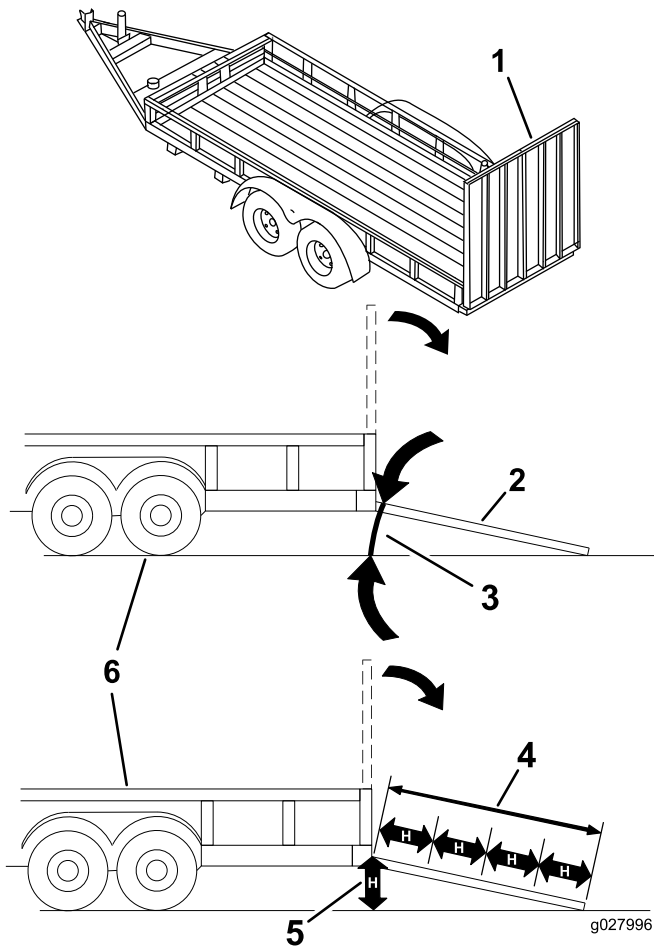

Figure 23

- | | |
|---|---|
| 1. Full-width ramp in stowed position | 4. Ramp is at least four times (4X) as long as the height of the trailer or truck bed to the ground |
| 2. Side view of full-width ramp in loading position | 5. H= height of the trailer or truck bed to the ground |
| 3. Not greater than 15 degrees | 6. Trailer |

Maintenance

Note: Determine the left and right sides of the machine from the normal operating position.

⚠ WARNING

While maintenance or adjustments are being made, someone could start the engine. Accidental starting of the engine could seriously injure you or other bystanders.

Remove the key from the ignition switch, engage parking brake, and pull the wire(s) off the spark plug(s) before you do any maintenance. Also push the wire(s) aside so it does not accidentally contact the spark plug(s).

⚠ WARNING

The engine can become very hot. Touching a hot engine can cause severe burns.

Allow the engine to cool completely before service or making repairs around the engine area.

Recommended Maintenance Schedule(s)

Maintenance Service Interval	Maintenance Procedure
After the first 5 hours	<ul style="list-style-type: none"> • Change the engine oil (Exmark 708cc Engine). • Change the engine oil (Kohler Engine). • Change the engine oil (Kawasaki Engine).
After the first 75 hours	<ul style="list-style-type: none"> • Change the hydraulic filter and fluid.
Before each use or daily	<ul style="list-style-type: none"> • Check the air cleaner for dirty, loose or damaged parts. • Check the engine oil (Exmark 708cc Engine). • Check the engine oil (Kohler Engine). • Check the engine oil (Kawasaki Engine). • Check the mower blades. • Check the safety interlock system. • Check the rollover protections systems (roll bar) knobs. • Check the seat belt. • Check for loose hardware. • Check the hydraulic oil level in the expansion tank. • Clean the engine and exhaust system area. • Clean the grass and debris build-up from the machine and cutting deck. • Clean the grass build-up from under the cutting deck.
Every 25 hours	<ul style="list-style-type: none"> • Clean the air cleaner foam element (more often in dusty, dirty conditions)(Exmark 708cc engine). • Service or replace the air cleaner precleaner (more often under extremely dusty, dirty conditions)(Kohler engine). • Grease the front caster axles (S- and E-Series Only).
Every 50 hours	<ul style="list-style-type: none"> • Service the air cleaner paper element (more often under extremely dusty, dirty conditions)(Kohler engine). • Check the tire pressures. • Check the condition of the belts. • Grease the deck and pump idler pivot. • Check spark arrester (if equipped).

Maintenance

Maintenance Service Interval	Maintenance Procedure
Every 100 hours	<ul style="list-style-type: none"> • Service the air cleaner paper element (more often in dusty, dirty conditions)(Exmark 708cc engine). • Replace the air cleaner foam element (more often in dusty, dirty conditions)(Exmark 708cc engine). • Replace the air cleaner paper element (more often under extremely dusty, dirty conditions)(Kohler engine). • Change the engine oil (change it more often under a heavy load or in high temperatures)(Exmark 708cc Engine). • Change the engine oil (change it more often under a heavy load or in high temperatures) (Kohler Engine). • Change the engine oil (change it more often under a heavy load or in high temperatures) (Kawasaki Engine). • Check the spark plug (Exmark 708cc engine). • Check the spark plug (Kawasaki engine). • Remove the engine shrouds and clean the cooling fins.
Every 200 hours	<ul style="list-style-type: none"> • Replace the air cleaner paper element (more often in dusty, dirty conditions)(Exmark 708cc engine). • Replace the spark plug (Exmark 708cc engine). • Check the spark plug (Kohler engine). • Replace the spark plug (Kawasaki engine).
Every 250 hours	<ul style="list-style-type: none"> • Replace the primary air filter (more often under extremely dusty, dirty conditions)(Kawasaki engine). • Check the safety air filter (more often under extremely dusty, dirty conditions)(Kawasaki engine).
Every 500 hours	<ul style="list-style-type: none"> • Replace the safety air filter (more often under extremely dusty, dirty conditions)(Kawasaki engine). • Replace the spark plug (Kohler engine). • Replace the emissions air intake filter (if applicable). • Change the hydraulic filter and fluid (Every 250 hours if using Mobil 1 15W50) May need more often under severe conditions. • Check the park brake adjustment.
Monthly	<ul style="list-style-type: none"> • Check the battery charge.
Yearly	<ul style="list-style-type: none"> • Grease the front caster axles (X-Series Only).

Important: For Kawasaki and Kohler Engines, refer to the Engine Owner's Manual for additional maintenance procedures.

Periodic Maintenance

Engine Maintenance

Important: If you are using a machine with an Exmark engine above 5,000 ft (1500 m) for a continuous period, ensure that the High Altitude Kit has been installed so that the engine meets CARB/EPA emission regulations. The High Altitude Kit increases engine performance while preventing spark fouling, hard starting, and increased emissions. Once you have installed the kit, attach the high-altitude label next to the serial decal on the machine (reference

Figure 1). Contact an Authorized Service Dealer to obtain the proper High Altitude Kit and high-altitude label for your machine. To locate a dealer convenient to you, access our web site at <http://www.Exmark.com> or contact our Exmark Customer Care Department at the number(s) listed in your Emission Control Warranty Statement. Remove the kit from the engine and restore the engine to its original factory configuration when running the engine under 5,000 ft (1500 m). Do Not operate an engine that has been converted for high-altitude use at a lower altitudes; otherwise, you could overheat and damage the engine. If you are unsure

whether or not your machine has been converted for high altitude use, look for the following label:

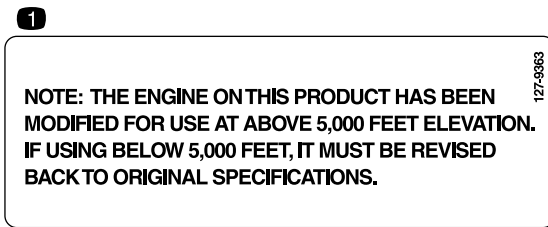

Figure 24

High Altitude Label

- Note: The engine on this product has been modified for use at above 5,000 feet elevation. If using below 5,000 feet, it must be revised back to original specifications.

Servicing the Air Cleaner—Exmark 708cc Engine

Service Interval: Every 100 hours/Yearly (whichever comes first)—Service the air cleaner paper element (more often in dusty, dirty conditions)(Exmark 708cc engine).

Every 200 hours/Every 2 years (whichever comes first)—Replace the air cleaner paper element (more often in dusty, dirty conditions)(Exmark 708cc engine).

Every 25 hours/Monthly (whichever comes first)—Clean the air cleaner foam element (more often in dusty, dirty conditions)(Exmark 708cc engine).

Every 100 hours/Yearly (whichever comes first)—Replace the air cleaner foam element (more often in dusty, dirty conditions)(Exmark 708cc engine).

Check the air cleaner daily or before starting the engine. Check for a buildup of dirt and debris around the air cleaner system. Keep this area clean. Also

check for loose or damaged components. Replace all bent or damaged air cleaner components.

Note: Operating the engine with loose or damaged air cleaner components could allow unfiltered air into the engine causing premature wear and failure.

Note: Service the air cleaner more often under extremely dusty, dirty conditions.

Removing the Elements:

- Park the machine on a level surface, disengage the blade control switch, move the motion control levers to the brake position, stop the engine, remove the key, and wait until all moving parts stop before leaving the operating position.
- Clean around the air cleaner cover to prevent dirt from getting into the engine and causing damage.
- Lift the cover and rotate the air-cleaner assembly out of the engine (see Figure 25 and Figure 26).

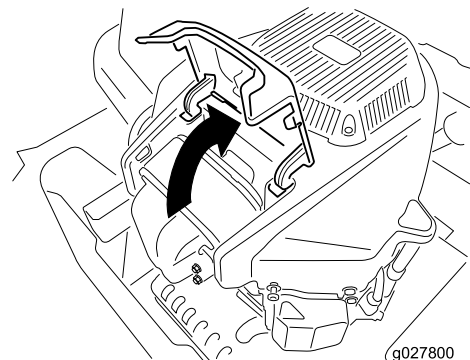

Figure 25

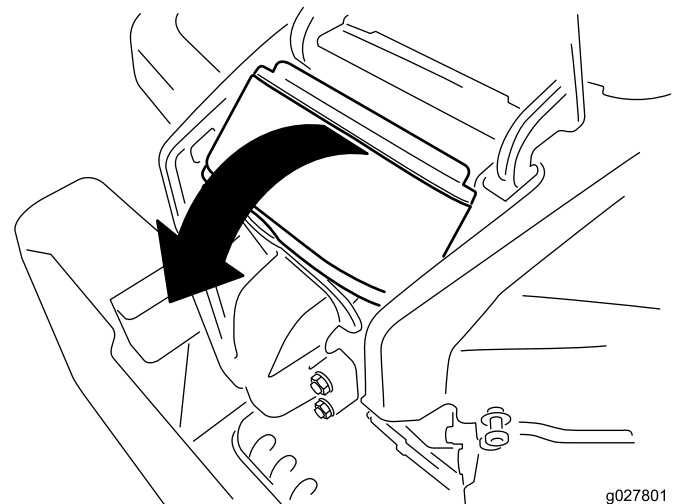

Figure 26

- Separate the foam and paper elements.

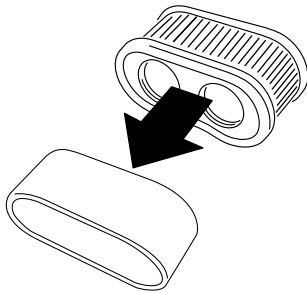

Figure 27

Cleaning the Foam and Paper Elements:

Foam Element:

Wash the foam element with water.

Important: Replace the foam element if it is torn or worn.

Paper Element:

1. Lightly tap the element on a flat surface to remove dust and dirt.
2. Inspect the element for tears, an oily film, and damage to the seal.

Important: Do not clean the paper element with pressurized air or liquids, such as solvent, gas, or kerosene. Replace the paper element if it is damaged or cannot be cleaned thoroughly.

To learn more about the Exmark twin-cylinder engine go to <http://exmark.com/engines> or scan the QR code.



Figure 28
708cc Engine

precleaner (more often under extremely dusty, dirty conditions)(Kohler engine).

Every 50 hours—Service the air cleaner paper element (more often under extremely dusty, dirty conditions)(Kohler engine).

Every 100 hours—Replace the air cleaner paper element (more often under extremely dusty, dirty conditions)(Kohler engine).

This engine is equipped with a replaceable, high density paper air cleaner element. Check the air cleaner daily or before starting the engine. Check for a buildup of dirt and debris around the air cleaner system. Keep this area clean. Also, check for loose or damaged components. Replace all bent or damaged air cleaner components.

Note: Operating the engine with loose or damaged air cleaner components could allow unfiltered air into the engine, causing premature wear and failure.

Note: Service the air cleaner more often under extremely dusty, dirty conditions.

1. Park the machine on a level surface, disengage the blade control switch, move the motion control levers to the brake position, stop the engine, remove the key, and wait until all moving parts stop before leaving the operating position.
2. Remove the cover to access the air cleaner element (see Figure 29).

Servicing the Air Cleaner—Kohler Engine

Service Interval: Before each use or daily—Check the air cleaner for dirty, loose or damaged parts.

Every 25 hours—Service or replace the air cleaner

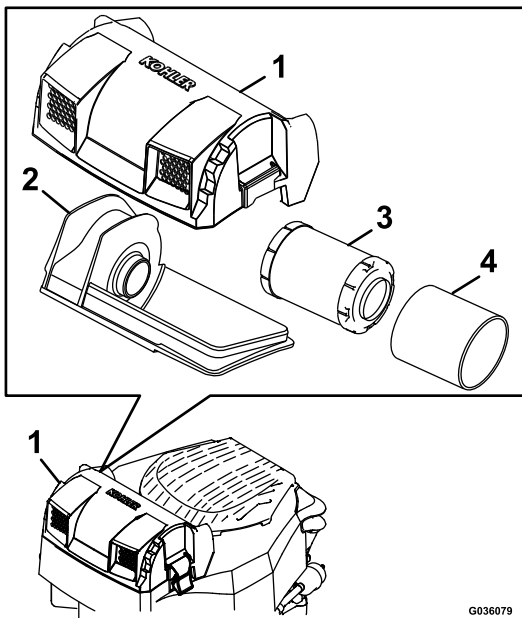

Figure 29

- | | |
|---------------------|------------------|
| 1. Cover | 3. Paper element |
| 2. Air cleaner base | 4. Precleaner |

- Remove the precleaner and paper element.
- Remove the element, and gently tap the element to dislodge dirt.

Note: Do Not wash the paper element or use pressurized air, as this will damage the element.

Note: Replace a dirty, bent, or damaged element. Handle the new element carefully; do not use if the sealing surfaces are bent or damaged.

- Wash the precleaner in warm water with detergent, rinse, and air dry.
- Lightly oil the precleaner with new engine oil and squeeze out excess oil.
- Clean the air cleaner base as required, and check the condition.
- Install the precleaner over the paper element.
- Install the precleaner and paper element onto the air cleaner base.
- Install the cover, and secure it with the latches.

Servicing the Air Cleaner—Kawasaki Engine

Service Interval: Every 250 hours—Replace the primary air filter (more often under extremely dusty, dirty

conditions)(Kawasaki engine).

Every 250 hours—Check the safety air filter (more often under extremely dusty, dirty conditions)(Kawasaki engine).

Every 500 hours—Replace the safety air filter (more often under extremely dusty, dirty conditions)(Kawasaki engine).

Note: Service the air cleaner more often under extremely dusty, dirty conditions.

- Park the machine on a level surface, disengage the blade control switch, move the motion control levers to the brake position, stop the engine, remove the key, and wait until all moving parts stop before leaving the operating position.
- Release the latches on the air cleaner and pull the air cleaner cover off the air-cleaner body (see Figure 30).

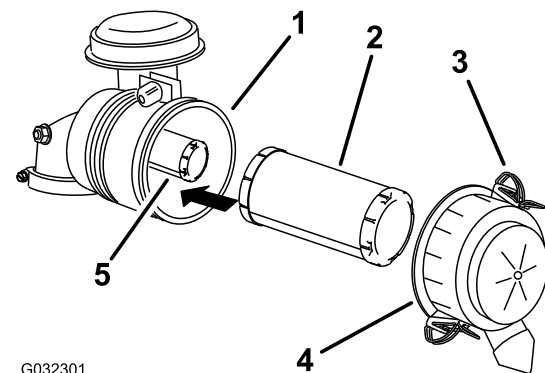

Figure 30

- | | |
|---------------------|----------------------|
| 1. Air cleaner body | 4. Air cleaner cover |
| 2. Primary filter | 5. Safety filter |
| 3. Latch | |

- Clean the inside of the air cleaner cover with compressed air.
- Gently slide the primary filter out of the air-cleaner body.

Note: Avoid knocking the filter into the side of the body.

5. Remove the safety filter only if you intend to replace it.

Important: Do not attempt to clean the safety filter. If the safety filter is dirty, then the primary filter is damaged. Replace both filters.

6. Inspect the primary filter for damage by looking into the filter while shining a bright light on the outside of the filter.

Note: Holes in the filter appear as bright spots. If the filter is damaged, discard it.

Servicing the Primary Filter–Kawasaki Engine

- If the primary filter is dirty, bent, or damaged, replace it.
- Do not clean the primary filter.

Servicing the Safety Filter–Kawasaki Engine

Replace the safety filter, never clean it.

Important: Do not attempt to clean the safety filter. If the safety filter is dirty, then the primary filter is damaged. Replace both filters.

Installing the Filters–Kawasaki Engine

Important: To prevent engine damage, always operate the engine with both air filters and the cover installed.

1. If installing new filters, check each filter for shipping damage.

Note: Do not use a damaged filter.

2. If you are replacing the safety filter, carefully slide it into the filter body (see Figure 30).
3. Carefully slide the primary filter over the safety filter.

Note: Ensure that the primary filter is fully seated by pushing on its outer rim while installing it.

Important: Do not press on the soft inside area of the filter.

4. Install the air cleaner cover with the side indicated as **up** facing upward and secure the latches.

Servicing the Engine Oil

Checking the Engine Oil Level–Exmark 708cc Engine

Service Interval: Before each use or daily

Important: Do not overfill the crankcase with oil and run the engine; engine damage may result.

1. Park the machine on a level surface, disengage the blade control switch, stop the engine, engage parking brake, and remove the key.
2. Make sure the engine is stopped, level, and is cool so the oil has had time to drain into the sump.
3. To keep dirt, grass clippings, etc., out of the engine, clean the area around the oil fill cap/dipstick before removing it.
4. Check the engine oil level.

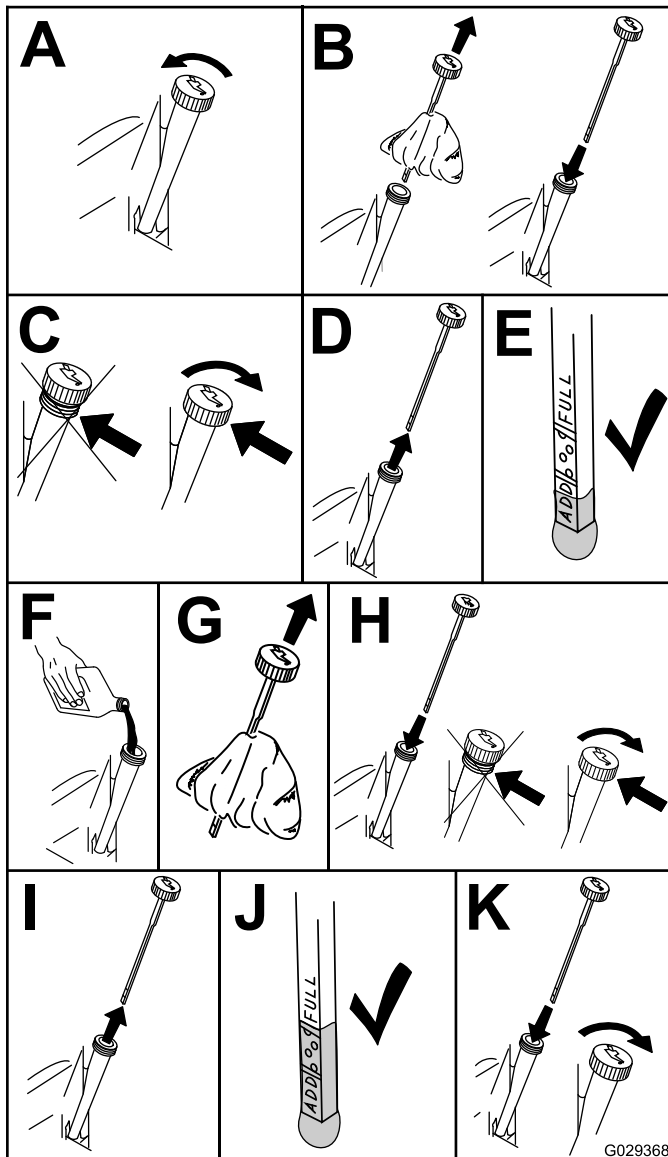

Figure 31

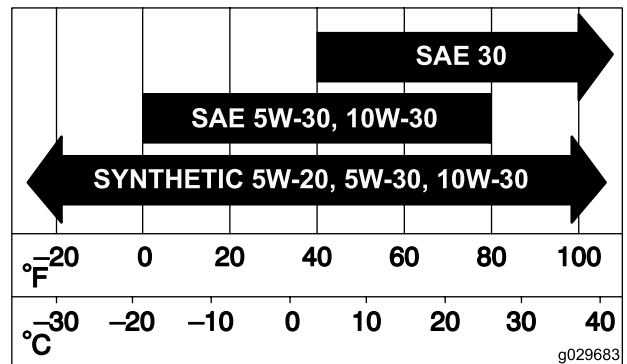

Figure 32
Viscosity table

Note: To prevent extensive engine wear or damage, always maintain the proper oil level in the crankcase. Never operate the engine with the oil level below the “ADD” mark or over the “FULL” mark on the dipstick.

Checking the Engine Oil—Kohler Engine

Service Interval: Before each use or daily

Important: Do not overfill the crankcase with oil and run the engine; engine damage may result.

1. Park the machine on a level surface, disengage the blade control switch, stop the engine, engage parking brake, and remove the key.
2. Make sure the engine is stopped, level, and is cool so the oil has had time to drain into the sump.
3. To keep dirt, grass clippings, etc., out of the engine, clean the area around the oil fill cap/dipstick before removing it.
4. Check the engine oil level.

5. If the level is low, wipe off the area around the oil fill cap, remove cap/dipstick and add oil to the “FULL” mark on the dipstick. Exmark 4-Cycle Premium Engine Oil is recommended; refer to the following information for an appropriate API rating and viscosity. Always check the level with the dipstick before adding more oil. **Do Not** overfill.

- Crankcase Capacity: 2.4 L (2.5 qt)
- Recommended Oil Type: Exmark 4-Cycle Premium Engine Oil
 - API service SF, SG, SH, SJ, or SL

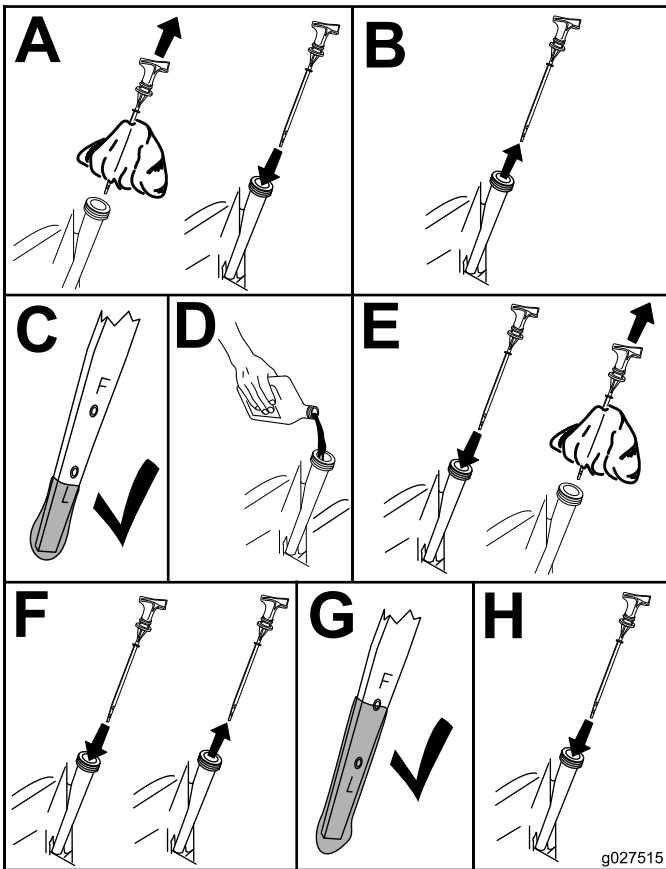

Figure 33

5. If the level is low, wipe off the area around the oil fill cap, remove cap/dipstick and add oil to the “F” (FULL) mark on the dipstick. Exmark 4-Cycle Premium Engine Oil is recommended; refer to the following information for an appropriate API rating and viscosity. Always check the level with the dipstick before adding more oil. **Do Not** overfill.

- Crankcase Capacity: 1.9L (2 qt) when the filter is changed.
- Recommended Oil Type: Exmark 4-Cycle Premium Engine Oil
 - API service SJ or higher

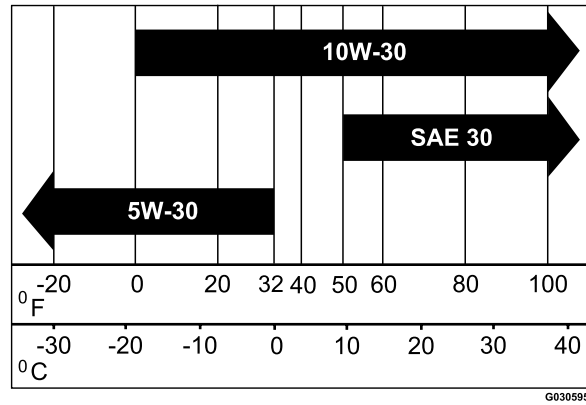

Figure 34
Viscosity table

Note: To prevent extensive engine wear or damage, always maintain the proper oil level in the crankcase. Never operate the engine with the oil level below the “L” (LOW) mark or over the “F” (FULL) mark on the dipstick.

Checking the Engine Oil-Kawasaki Engine

Service Interval: Before each use or daily

Important: Do not overfill the crankcase with oil and run the engine; engine damage may result.

1. Park the machine on a level surface, disengage the blade control switch, stop the engine, engage parking brake, and remove the key.
2. Make sure the engine is stopped, level, and is cool so the oil has had time to drain into the sump.
3. To keep dirt, grass clippings, etc., out of the engine, clean the area around the oil fill cap/dipstick before removing it.
4. Check the engine oil level.

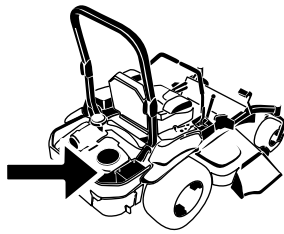

G008804

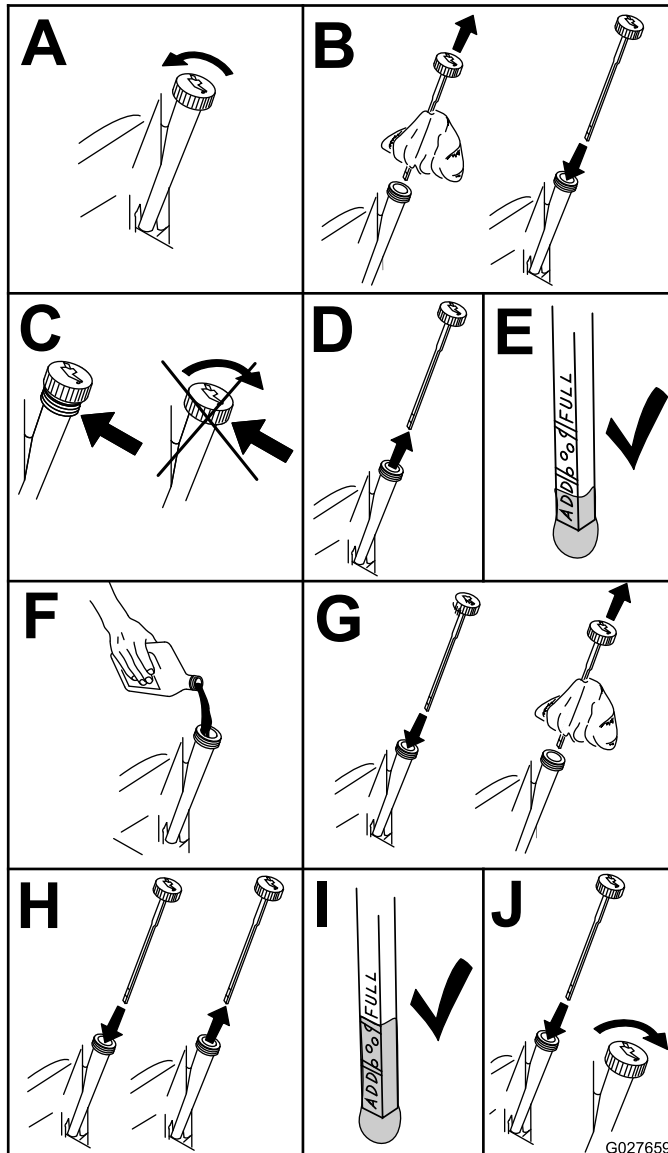
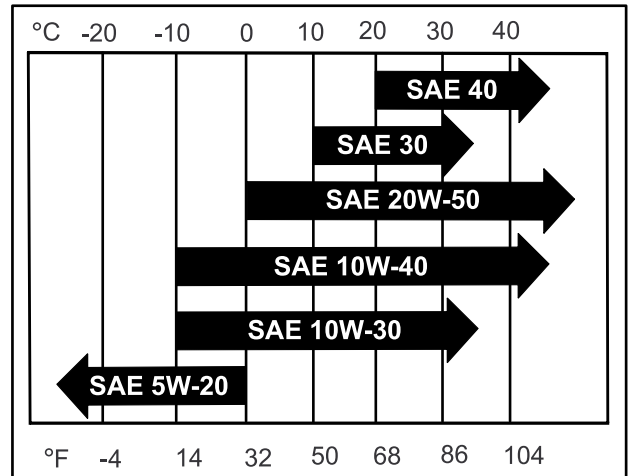

Figure 35

- If the level is low, wipe off the area around the oil fill cap, remove cap/dipstick and add oil to the "FULL" mark on the dipstick. Exmark 4-Cycle Premium Engine Oil is recommended; refer to the following information for an appropriate API rating and viscosity. Always check the level with the dipstick before adding more oil. **Do Not** overfill.

- Crankcase Capacity: 2.1 L (2.2 qt) when the filter is changed.
- Recommended Oil Type: Exmark 4-Cycle Premium Engine Oil
 - API service SF, SG, SH, SJ, or SL



g037096

Figure 36
Viscosity table

Note: To prevent extensive engine wear or damage, always maintain the proper oil level in the crankcase. Never operate the engine with the oil level below the "ADD" mark or over the "FULL" mark on the dipstick.

Changing the Engine Oil-Exmark 708cc Engine

Service Interval: After the first 5 hours

Every 100 hours (change it more often under a heavy load or in high temperatures)(Exmark 708cc Engine).

- Park the machine so that the drain side is slightly lower than the opposite side to ensure the oil drains completely.
- Start the engine and let it run until warm. This warms the oil so it drains better.
- Disengage the blade control switch and ensure the parking brake is engaged.
- Stop the engine, remove the key, and wait for all moving parts to stop before leaving the operating position.

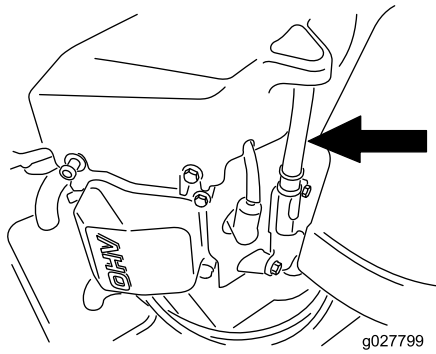

Figure 37

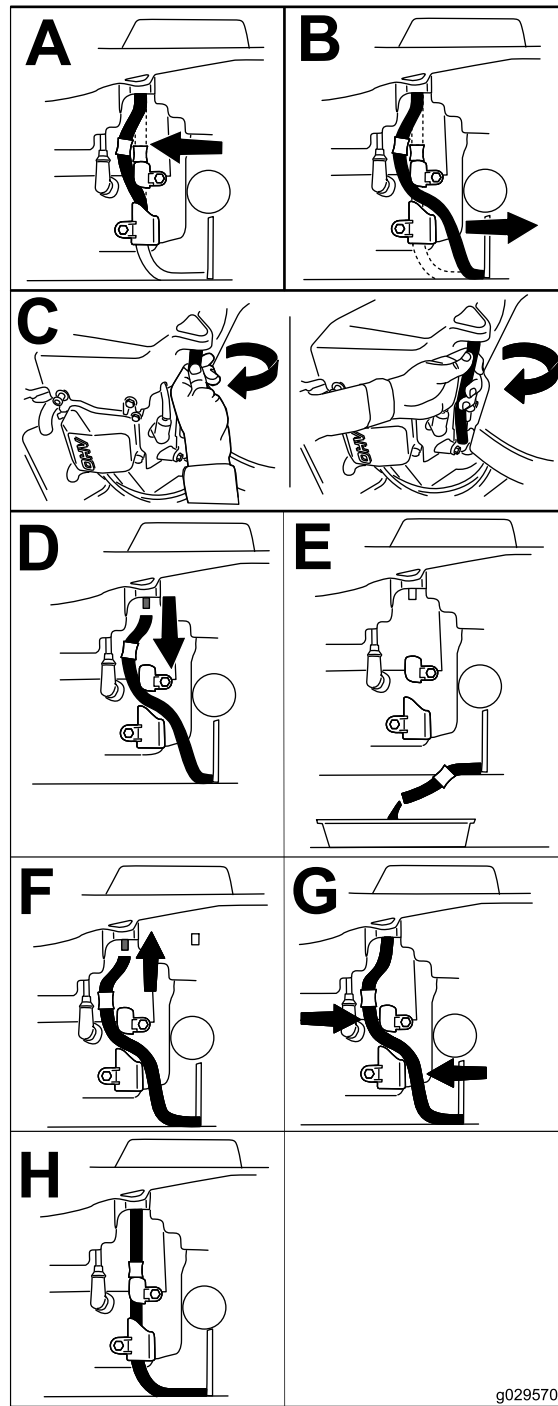

Figure 38

5. Change the engine oil filter. Apply a thin film of clean Exmark 4-Cycle Premium Engine Oil to the rubber gasket on the new filter.

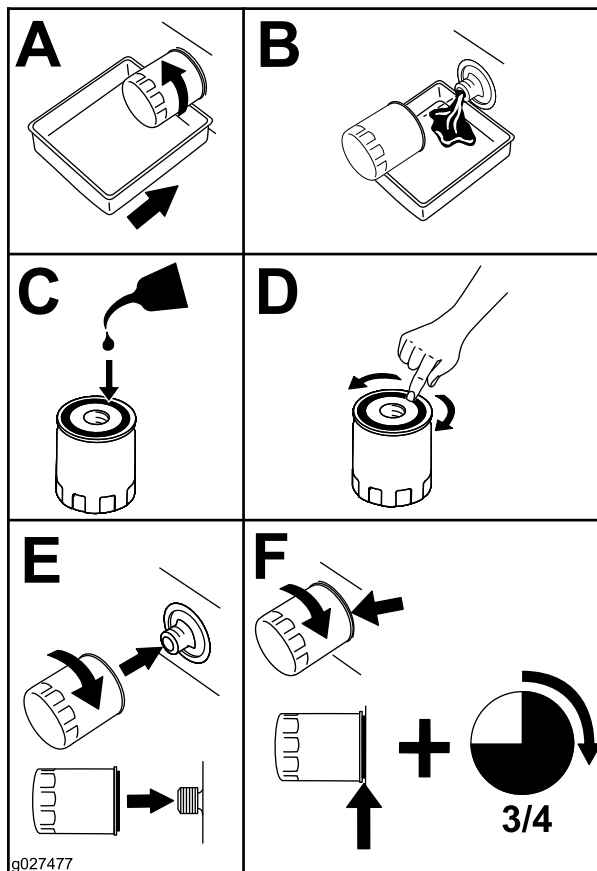

Figure 39

Note: Ensure the oil filter gasket touches the engine, then an extra 3/4 turn is completed.

Note: Dispose of the used oil at a recycling center.

- Slowly pour approximately 80% of the specified oil into the filler tube—use oil recommended in the **Checking the Engine Oil Level—Exmark 708cc Engine** section.

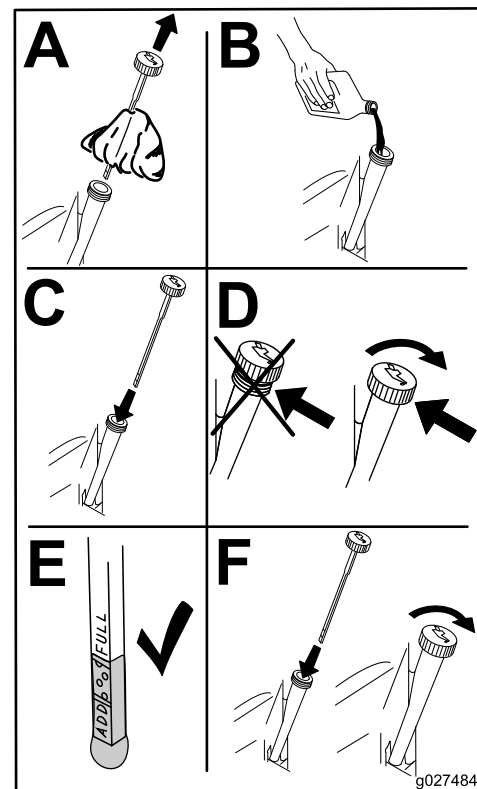

Figure 40

- Check the oil level; refer to **Checking the Engine Oil Level—Exmark 708cc Engine** section.
- Start the engine and check for leaks.

Changing the Engine Oil-Kohler Engine

Service Interval: After the first 5 hours

Every 100 hours (change it more often under a heavy load or in high temperatures) (Kohler Engine).

- Park the machine so that the drain side is slightly lower than the opposite side to ensure the oil drains completely.
- Start the engine and let it run until warm. This warms the oil so it drains better.
- Disengage the blade control switch and ensure the parking brake is engaged.
- Stop the engine, remove the key, and wait for all moving parts to stop before leaving the operating position.

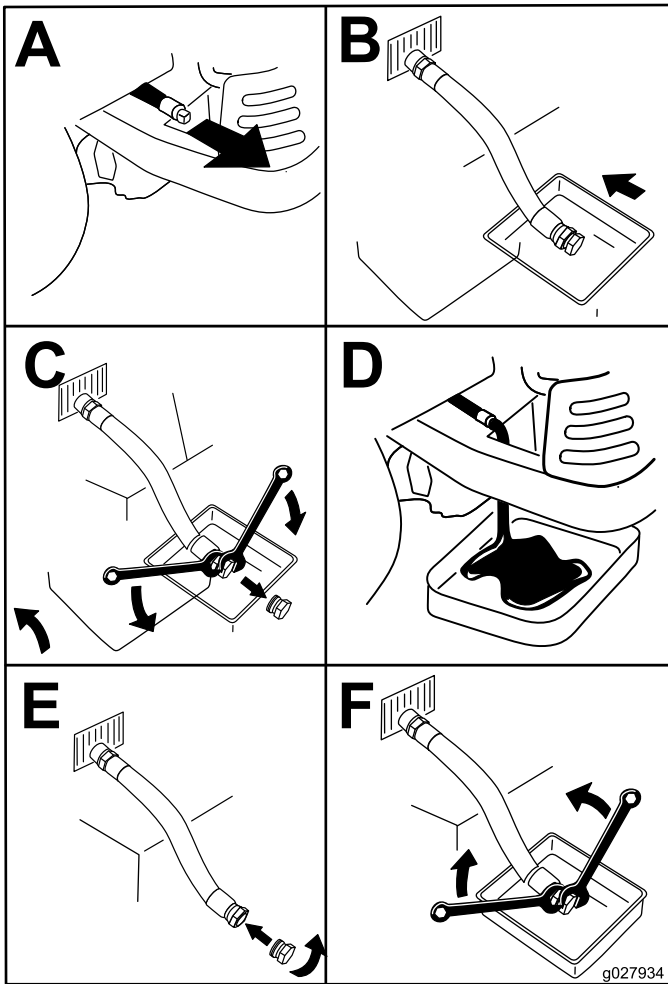

Figure 41

Note: Torque the plug to 14 N-m (125 in-lb).

5. Change the engine oil filter. Apply a thin film of clean Exmark 4-Cycle Premium Engine Oil to the rubber gasket on the new filter.

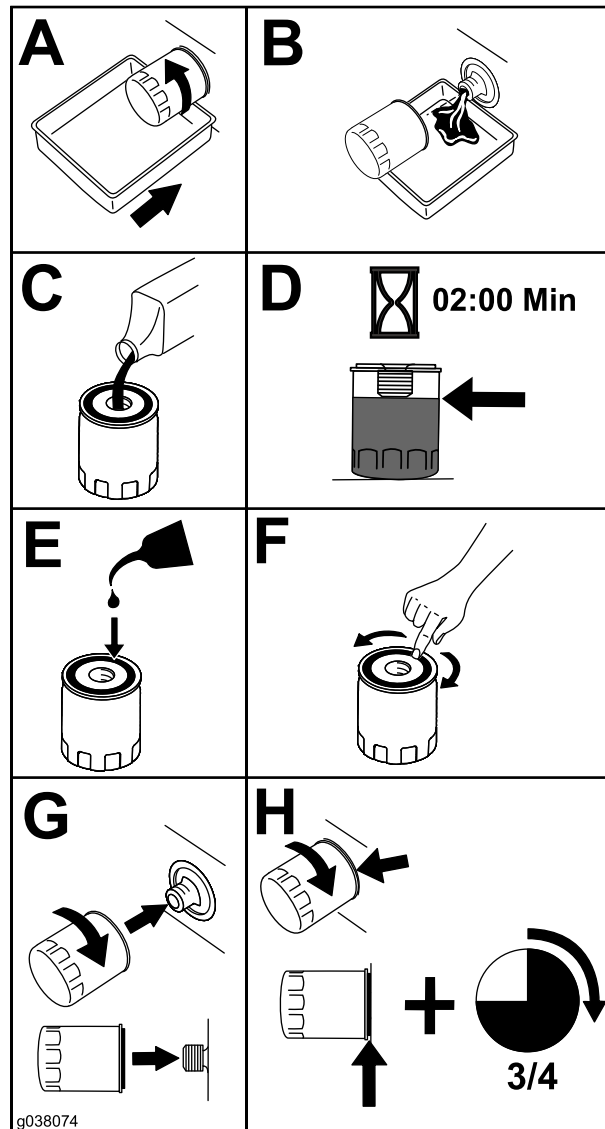

Figure 42

Note: Ensure the oil filter gasket touches the engine, then an extra 3/4 turn is completed.

Note: Dispose of the used oil at a recycling center.

6. Slowly pour approximately 80% of the specified oil into the filler tube—use oil recommended in the **Checking the Engine Oil—Kohler Engine** section.

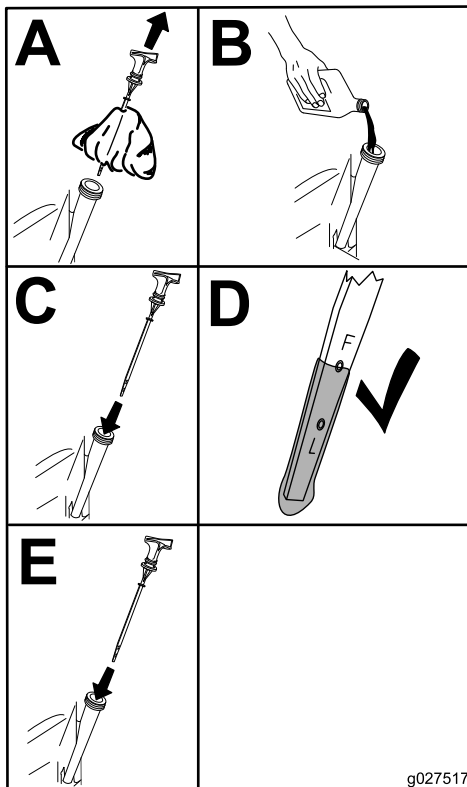

Figure 43

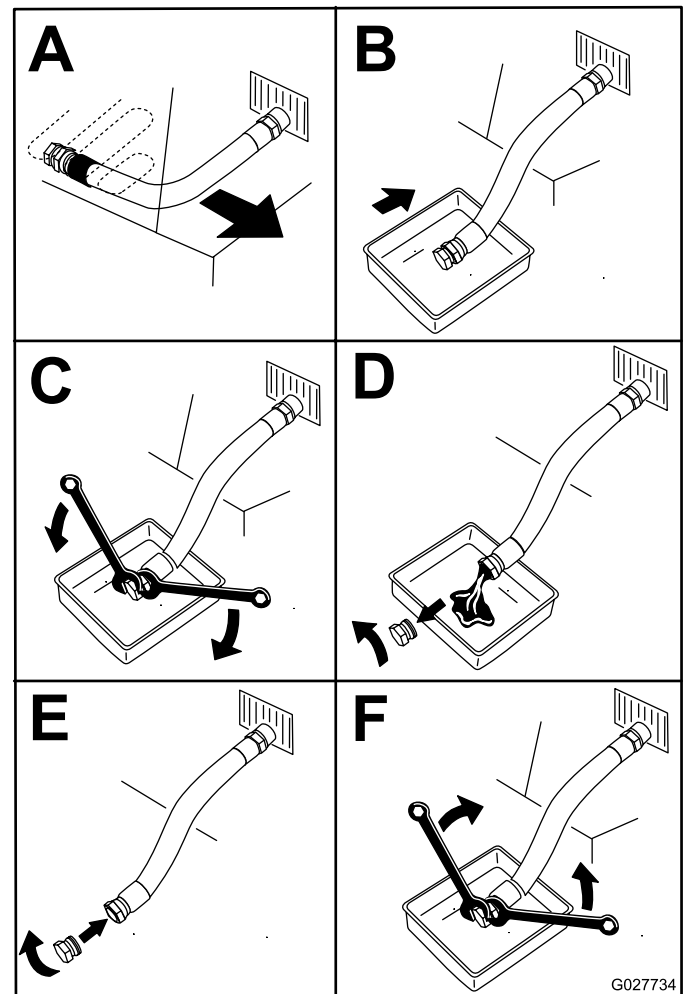

Figure 44

7. Check the oil level; refer to **Checking the Engine Oil—Kohler Engine** section.
8. Start the engine and check for leaks.

Changing the Engine Oil-Kawasaki Engine

Service Interval: After the first 5 hours

Every 100 hours (change it more often under a heavy load or in high temperatures) (Kawasaki Engine).

1. Park the machine so that the drain side is slightly lower than the opposite side to ensure the oil drains completely.
2. Start the engine and let it run until warm. This warms the oil so it drains better.
3. Disengage the blade control switch and ensure the parking brake is engaged.
4. Stop the engine, remove the key, and wait for all moving parts to stop before leaving the operating position.

Note: Torque the plug to 14 N-m (125 in-lb).

5. Change the engine oil filter. Apply a thin film of clean Exmark 4-Cycle Premium Engine Oil to the rubber gasket on the new filter.

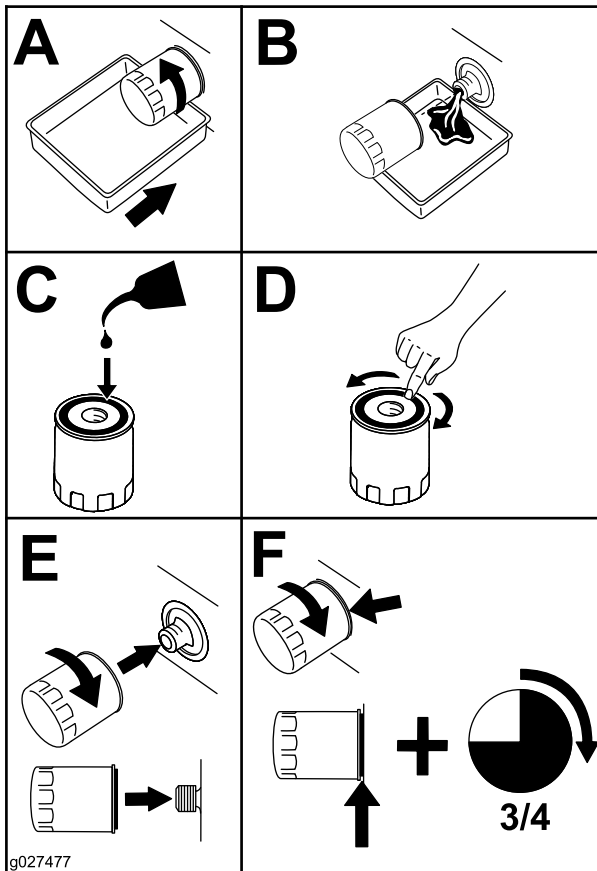

Figure 45

Note: Ensure the oil filter gasket touches the engine, then an extra 3/4 turn is completed.

Note: Dispose of the used oil at a recycling center.

- Slowly pour approximately 80% of the specified oil into the filler tube—use oil recommended in the **Checking the Engine Oil—Kawasaki Engine** section.

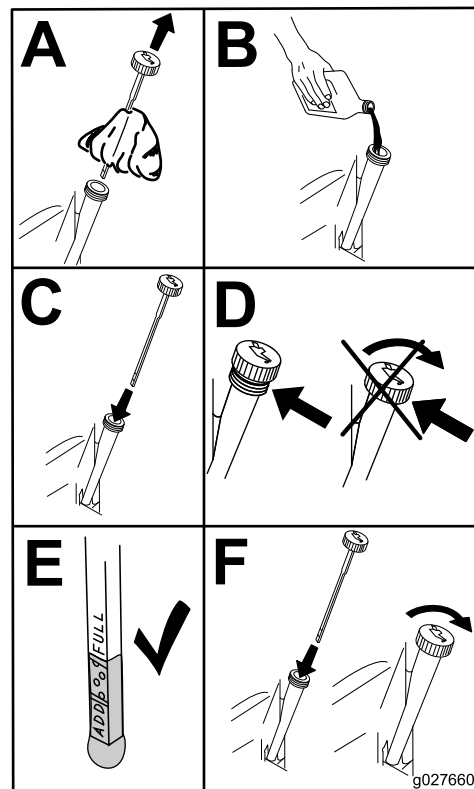

Figure 46

- Check the oil level; refer to **Checking the Engine Oil—Kawasaki Engine** section.
- Start the engine and check for leaks.

Servicing the Spark Plug-Exmark 708cc Engine

Service Interval: Every 100 hours/Yearly (whichever comes first)—Check the spark plug (Exmark 708cc engine).

Every 200 hours/Every 2 years (whichever comes first)—Replace the spark plug (Exmark 708cc engine).

Ensure that the air gap between the center and side electrodes is correct before installing the spark plug. Use a spark plug wrench for removing and installing the spark plug and a gapping tool or feeler gauge to check and adjust the air gap. Install a new spark plug if necessary.

Type: Champion RN9YC or equivalent

Air Gap: 0.030 inch (.76 mm)

Removing the Spark Plug-Exmark 708cc engine

1. Disengage the PTO and ensure the parking brake is engaged.
2. Stop the engine, remove the key, and wait for all moving parts to stop before leaving the operating position.
3. Disconnect the wire from the spark plug.

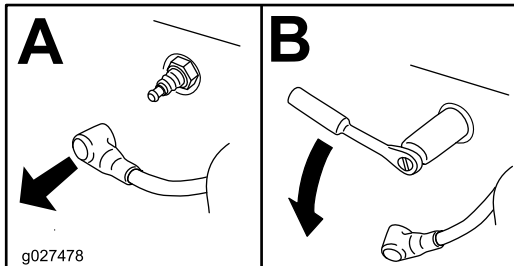

Figure 47

Note: Due to the deep recess around the spark plug, blowing out the cavity with compressed air is usually the most effective method for cleaning. The spark plug is most accessible when the blower housing is removed for cleaning.

Checking the Spark Plug-Exmark 708cc Engine

1. Inspect the spark plug

Note: If you see light brown or gray on the insulator, the engine is operating properly. A black coating on the insulator usually means the air cleaner is dirty.

Important: Do Not clean the spark plug(s). Always replace the spark plug(s) when it has a black coating, worn electrodes, an oily film, or cracks.

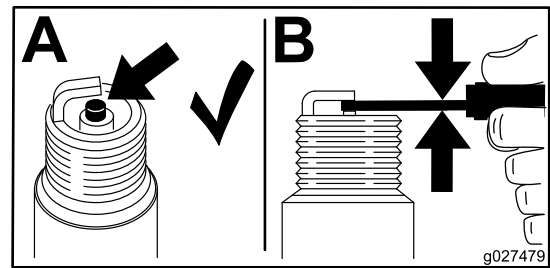

Figure 48

1. Center electrode insulator
2. Side electrode
3. Air gap (not to scale)

2. Check the gap between the center and side electrodes.
3. Set the gap to 0.030 inch (.76 mm).

Installing the Spark Plug-Exmark 708cc Engine

1. Install the spark plug. Make sure that the air gap is set correctly.
2. Tighten the spark plug to 18.5–22.1 ft-lb (25–30 N-m).

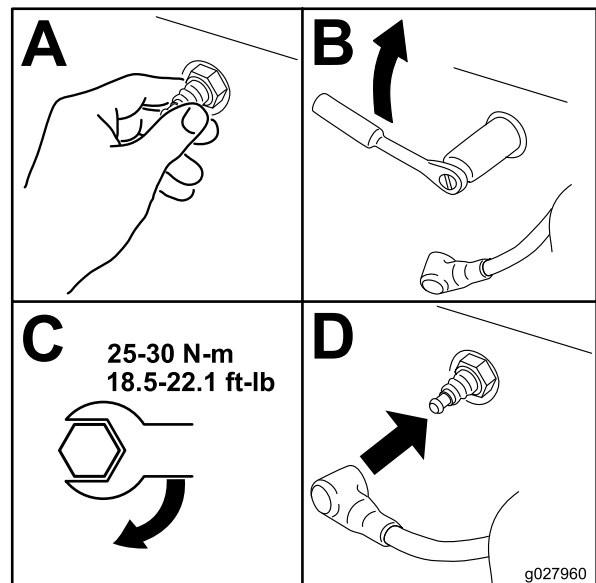

Figure 49

3. Push the wire onto the spark plug.

Servicing the Spark Plug-Kohler Engine

Service Interval: Every 200 hours—Check the spark plug (Kohler engine).

Every 500 hours—Replace the spark plug (Kohler engine).

Ensure that the air gap between the center and side electrodes is correct before installing the spark plug. Use a spark plug wrench for removing and installing the spark plug and a gapping tool or feeler gauge to check and adjust the air gap. Install a new spark plug if necessary.

The spark plug is RFI compliant. Equivalent alternate brand plugs can also be used.

Type: Champion XC12YC or equivalent

Air Gap: 0.030 inch (.76 mm)

Removing the Spark Plug-Kohler Engine

1. Disengage the PTO and ensure the parking brake is engaged.
2. Stop the engine, remove the key, and wait for all moving parts to stop before leaving the operating position.
3. Disconnect the wire from the spark plug.

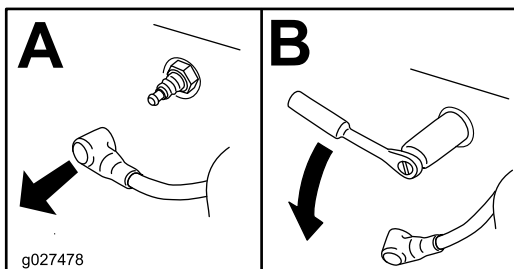

Figure 50

4. Clean around the spark plug to prevent dirt from falling into the engine and potentially causing damage.
5. Remove the spark plug and metal washer.

Checking the Spark Plug-Kohler Engine

1. Inspect the spark plug

Note: If you see light brown or gray on the insulator, the engine is operating properly. A black coating on the insulator usually means the air cleaner is dirty.

Important: Do Not clean the spark plug. Always replace the spark plug when it has a black coating, worn electrodes, an oily film, or cracks.

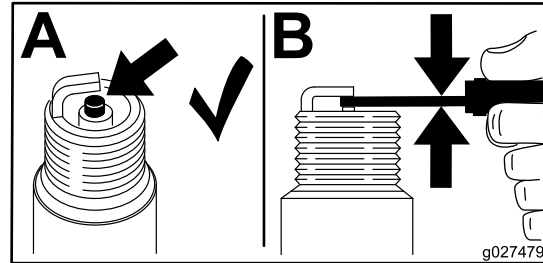

Figure 51

1. Center electrode insulator
 2. Side electrode
 3. Air gap (not to scale)
2. Check the gap between the center and side electrodes.
 3. Set the gap to 0.030 inch (.76 mm).

Installing the Spark Plug-Kohler Engine

1. Install the spark plug. Make sure that the air gap is set correctly.
2. Tighten the spark plug to 18 to 22 ft-lb (25 to 29 N-m).

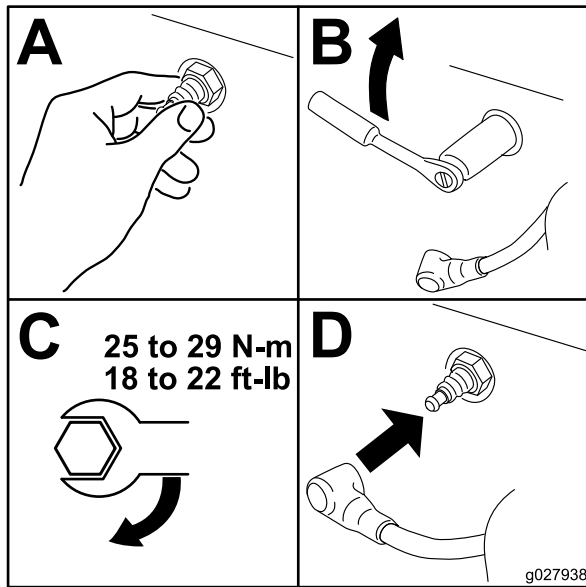

Figure 52

3. Push the wire onto the spark plug.

Servicing the Spark Plug-Kawasaki Engine

Service Interval: Every 100 hours/Yearly (whichever comes first)—Check the spark plug (Kawasaki engine).

Every 200 hours/Every 2 years (whichever comes first)—Replace the spark plug (Kawasaki engine).

Ensure that the air gap between the center and side electrodes is correct before installing the spark plug. Use a spark plug wrench for removing and installing the spark plug and a gapping tool or feeler gauge to check and adjust the air gap. Install a new spark plug if necessary.

The spark plug is RFI compliant. Equivalent alternate brand plugs can also be used.

Type : NGK® BPR4ES or equivalent

Air Gap: 0.030 inch (.76 mm)

1. Disengage the PTO and ensure the parking brake is engaged.
2. Stop the engine, remove the key, and wait for all moving parts to stop before leaving the operating position.

3. Disconnect the wire from the spark plug.

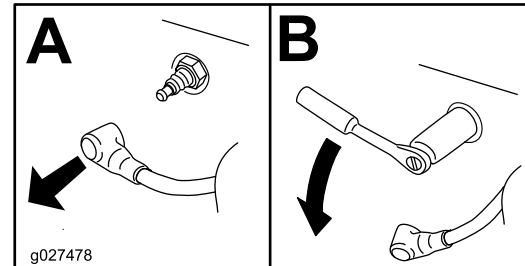

Figure 53

4. Clean around the spark plug to prevent dirt from falling into the engine and potentially causing damage.
5. Remove the spark plug and metal washer.

Checking the Spark Plug-Kawasaki Engine

1. Inspect the spark plug

Note: If you see light brown or gray on the insulator, the engine is operating properly. A black coating on the insulator usually means the air cleaner is dirty.

Important: Do Not clean the spark plug. Always replace the spark plug when it has a black coating, worn electrodes, an oily film, or cracks.

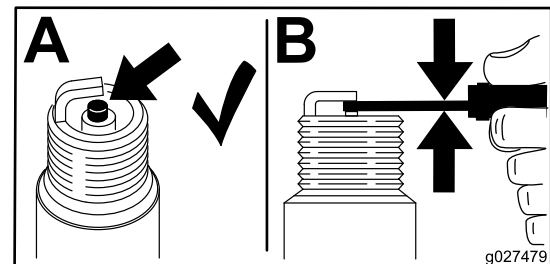

Figure 54

1. Center electrode
 2. Side electrode
 3. Air gap (not to scale)
2. Check the gap between the center and side electrodes.
 3. Set the gap to 0.030 inch (.76 mm).

Maintenance

Installing the Spark Plug–Kawasaki Engine

1. Install the spark plug. Make sure that the air gap is set correctly.
2. Tighten the spark plug to 16 ft-lb (22 N-m).

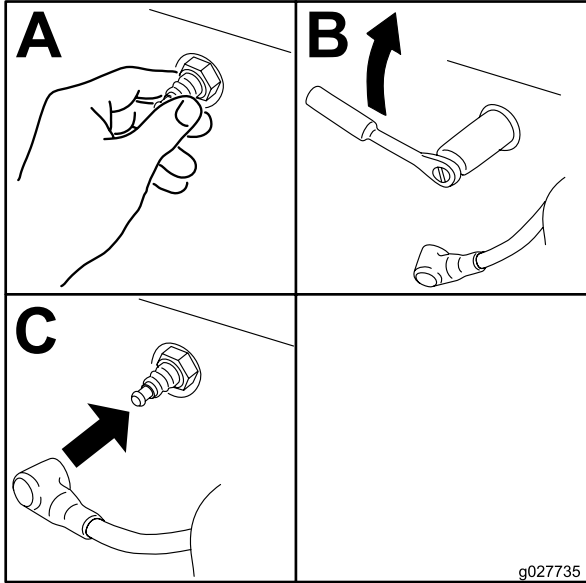

Figure 55

3. Push the wire onto the spark plug.

Check Battery Charge

Service Interval: Monthly

⚠ WARNING

CALIFORNIA Proposition 65 Warning

Battery posts, terminals, and related accessories contain lead and lead compounds, chemicals known to the State of California to cause cancer and reproductive harm. Wash hands after handling.

Allowing batteries to stand for an extended period of time without recharging them will result in reduced performance and service life. To preserve optimum battery performance and life, recharge batteries in storage when the open circuit voltage drops to 12.4 volts.

Note: To prevent damage due to freezing, battery should be fully charged before putting away for winter storage.

Check the voltage of the battery with a digital voltmeter. Locate the voltage reading of the battery in the table and charge the battery for the recommended time interval to bring the charge up to a full charge of 12.6 volts or greater.

Important: Make sure the negative battery cable is disconnected and the battery charger used for charging the battery has an output of 16 volts and 7 amps or less to avoid damaging the battery (see chart for recommended charger settings).

Voltage Reading	Percent Charge	Maximum Charger Settings	Charging Interval
12.6 or greater	100%	16 volts/7 amps	No Charging Required
12.4 – 12.6	75–100%	16 volts/7 amps	30 Minutes
12.2 – 12.4	50–75%	16 volts/7 amps	1 Hour
12.0–12.2	25–50%	14.4 volts/4 amps	2 Hours
11.7–12.0	0–25%	14.4 volts/4 amps	3 Hours
11.7 or less	0%	14.4 volts/2 amps	6 Hours or More

Recommended Jump Starting Procedure

Service Interval: As required

1. Check the weak battery for terminal corrosion (white, green, or blue “snow”), it must be cleaned off prior to jump starting. Clean and tighten connections as necessary.

⚠ CAUTION

Corrosion or loose connections can cause unwanted electrical voltage spikes at anytime during the jump starting procedure.

Do Not attempt to jump start with loose or corroded battery terminals or damage to the engine may occur.

⚠ DANGER

Jump starting a weak battery that is cracked, frozen, has low electrolyte level, or an open/shorted battery cell, can cause an explosion resulting in serious personal injury.

Do Not jump start a weak battery if these conditions exist.

2. Make sure the booster is a good and fully charged lead acid battery at 12.6 volts or greater. Use properly sized jumper cables (4 to 6 AWG) with short lengths to reduce voltage drop between systems. Make sure the cables are color coded or labeled for the correct polarity.

⚠ CAUTION

Connecting the jumper cables incorrectly (wrong polarity) can immediately damage the electrical system.

Be certain of battery terminal polarity and jumper cable polarity when hooking up batteries.

Note: The following instructions are adapted from the SAE J1494 Rev. Dec. 2001 – Battery Booster Cables – Surface Vehicle Recommended Practice (SAE – Society of Automotive Engineers).

⚠ WARNING

Batteries contain acid and produce explosive gases.

- Shield the eyes and face from the batteries at all times.
- Do Not lean over the batteries.

Note: Be sure the vent caps are tight and level. Place a damp cloth, if available, over any vent caps on both batteries. Be sure the vehicles do not touch and that both electrical systems are off and at the same rated system voltage. These instructions are for negative ground systems only.

3. Connect the positive (+) cable to the positive (+) terminal of the discharged battery that is wired to the starter or solenoid as shown in Figure 56.

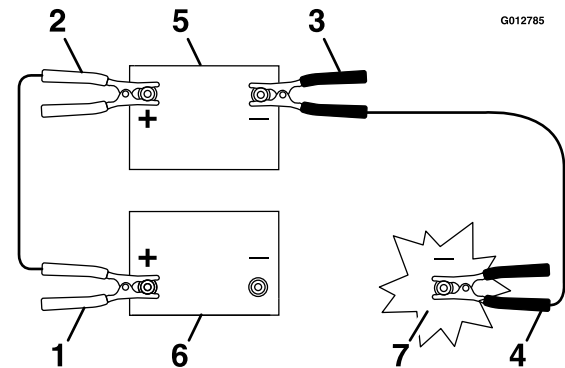

Figure 56

1. Positive (+) cable on discharged battery
2. Positive (+) cable on booster battery
3. Negative (-) cable on the booster battery
4. Negative (-) cable on the engine block
5. Booster battery
6. Discharged battery
7. Engine block

4. Connect the other end of the positive cable to the positive terminal of the booster battery.
5. Connect the black negative (-) cable to the other terminal (negative) of the booster battery.
6. MAKE THE FINAL CONNECTION ON THE ENGINE BLOCK OF THE STALLED VEHICLE (NOT TO THE NEGATIVE POST) AWAY FROM THE BATTERY. STAND BACK.
7. Start the vehicle and remove the cables in the reverse order of connection (the engine block (black) connection is the first to disconnect).

Check Mower Blades

Service Interval: Before each use or daily

1. Stop engine, wait for all moving parts to stop, and remove key. Engage parking brake.
2. Lift deck and secure in raised position as stated in the **Clean Grass Build-Up Under Deck** section.
3. Inspect blades and sharpen or replace as required.
4. Reinstall the blades (if they were removed) in the following order:
 - A. Install the either the splined bushing or blade:
 - X-Series:

Install the splined bushing through the blade with the bushing flange on bottom (grass) side of blade.

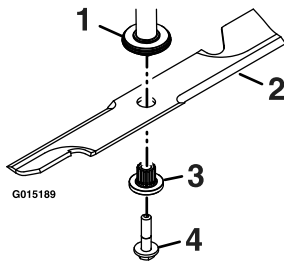

Figure 57

1. Spindle
2. Blade
3. Splined bushing
4. Blade bolt washer assembly — Torque to 50-60 ft-lb (68-81 N-m) Apply lubricant to threads as needed to prevent seizing. Copper-based anti-seize preferable. Grease acceptable substitute.

- S- and E-Series:

Install the blade onto the spindle shaft.

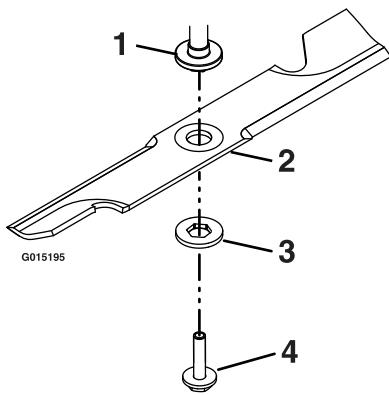

Figure 58

1. Spindle
2. Blade
3. Blade drive washer
4. Blade bolt washer assembly — Torque to 50-60 ft-lb (68-81 N-m) Apply lubricant to threads as needed to prevent seizing. Copper-based anti-seize preferable. Grease acceptable substitute.

Important: On rear discharge decks, the RH blade rotates counterclockwise. Be sure to reinstall that blade onto the RH spindle only.

⚠ WARNING

Incorrect installation of the blade or components used to retain the blade can be dangerous. Failure to use all original components and assembled as shown could allow a blade or blade component to be thrown out from under the deck resulting in serious personal injury or death.

Always install the original Exmark blades, blade bushings, and blade bolts as shown.

- B. Apply lubricant to the threads of the blade bolt as needed to prevent seizing. Copper based anti-seize is preferable. Grease is an acceptable substitute.
- C. Install the splined bushing/blade assembly and blade bolt washer assembly into the spindle. Install blade bolt finger tight.
- D. Place wrench on the top spindle nut then torque the blade bolts to 50-60 ft-lb (68-81 N-m).

Check Safety Interlock System





Service Interval: Before each use or daily

Important: It is essential that operator safety mechanisms be connected and in proper operating condition prior to use.

Note: If machine does not pass any of these tests, **Do Not** operate. Contact an Authorized Service Dealer.

Note: To prevent engine cut-outs on rough terrain, the seat has a 1/2 second time delay before the engine begins to shutdown.

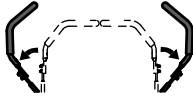









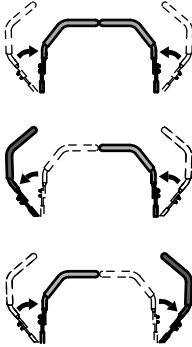

Check the Normal Engine Starting Chart

	System				
	Parking Brake	PTO	Motion Control Levers	Operator	Outcome
State of System	Engaged 	Disengaged (Blades) 	Both levers out (neutral lock) 	In seat or out of the seat 	Starter should crank 

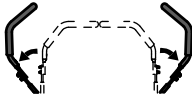
Maintenance



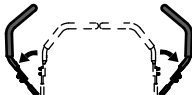









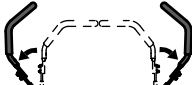











Check Engine Starting Circuit Chart

Note: In the **Check Engine Starting Circuit Chart**, the state of system item that is bold is being checked in each scenario.

	System				Outcome
	Parking Brake	PTO (Blades)	Motion Control Levers	Operator	
State of System	Engaged 	Disengaged 	Both levers moved in, or either right or left lever moved in 	Operator in seat 	Starter must not crank 
	Disengaged 	Disengaged 	Both levers out (neutral lock) 	Operator in seat 	Starter must not crank 
	Engaged 	Engaged 	Both levers out (neutral lock) 	Operator in seat 	Starter must not crank 

Check Shutdown Circuit Chart

Note: The state of system item(s) that is bold is being checked in each scenario.

	System					Outcome
	Engine	Parking Brake	PTO (Blades)	Motion Control Levers	Operator	
State of System	Running idle (1/3 throttle) 	Disengaged 	Disengaged 	Both levers moved out (neutral lock), both levers moved in, or either right or left lever moved in    	Raise off of seat (but don't get off) 	Engine must begin shutdown within 1 second 00:00:01  
	Running idle (1/3 throttle) 	Disengaged 	Engaged 	Both levers moved in 	Raise off of seat (but don't get off) 	Engine must begin shutdown within 1 second 00:00:01  
	Running idle (1/3 throttle) 	Engaged 	Disengaged 	Both levers moved in, or either right or left lever moved in   	Operator in seat 	Engine must begin shutdown within 1 second 00:00:01  

Check Rollover Protections Systems (Roll Bar) Knobs

Service Interval: Before each use or daily

Check that both the mounting hardware and the knobs are in good working condition. Make sure the knobs are fully engaged with the ROPS in the raised position. The upper hoop of the roll bar may need to be pushed forward or pulled rearward to get both knobs fully engaged.

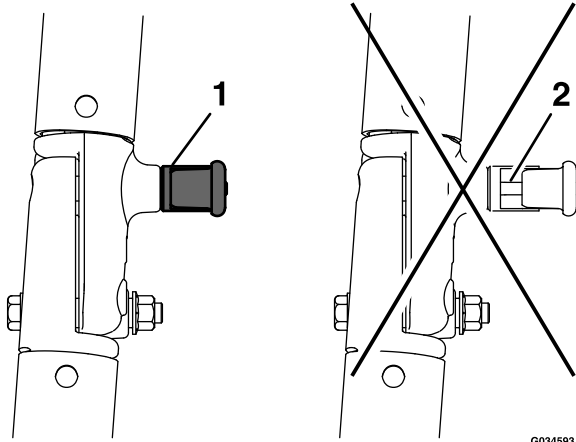

Figure 59

1. Engaged

2. Partially engaged — Do Not operate with ROPS in this condition.

G034593

Check Seat Belt

Service Interval: Before each use or daily

Visually inspect seat belt for wear, cuts, and proper operation of retractor and buckle. Replace before operating if damaged.

Check for Loose Hardware

Service Interval: Before each use or daily

1. Stop engine, wait for all moving parts to stop, and remove key. Engage parking brake.
2. Visually inspect machine for any loose hardware or any other possible problem. Tighten hardware or correct the problem before operating.

Check Hydraulic Oil Level

Service Interval: Before each use or daily

1. Stop engine and wait for all moving parts to stop. Engage parking brake.
2. Wait until the unit cools before checking the hydraulic oil.
3. Check expansion tank and if necessary add Exmark Premium Hydro Oil to the FULL COLD line (see Figure 60).

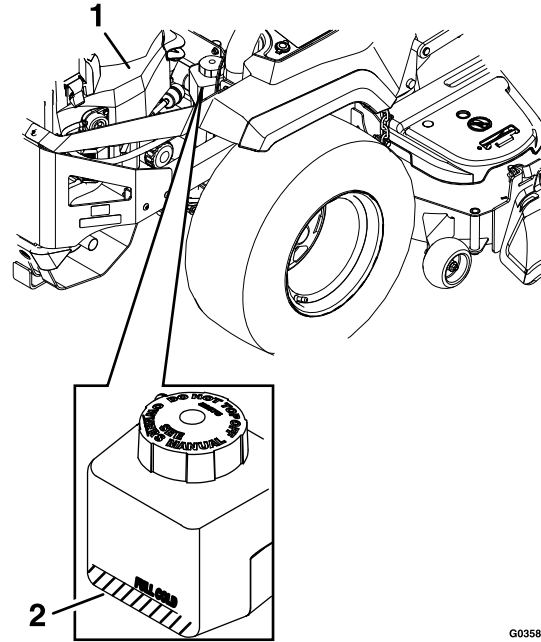

Figure 60

1. Engine

2. Expansion tank

G035689

Check Tire Pressures

Service Interval: Every 50 hours

1. Stop engine, wait for all moving parts to stop, and remove key. Engage parking brake.
2. Check tire pressure in drive tires.
3. Inflate drive tires to 13 psi (90 kPa).
4. Check tire pressure in caster tires.
5. Inflate caster tires to 13 psi (90 kPa).

Check Condition Of Belts

Service Interval: Every 50 hours

1. Stop engine, wait for all moving parts to stop, and remove key. Engage parking brake.
2. Remove left and right belt shields on deck and lower the deck to inspect deck drive belt.
3. Check under machine to inspect the pump drive belt.

Note: No adjustments are required for belt tension.

Lubricate Grease Fittings

Note: See chart for service intervals.

1. Stop engine, wait for all moving parts to stop, and remove key. Engage parking brake.
2. Lubricate fittings with one to two pumps of NLGI grade #2 multi-purpose gun grease.

Refer to the following chart for fitting locations and lubrication schedule.

Lubrication Chart			
Fitting Locations	Initial Pumps	Number of Places	Service Interval
1. Deck and Pump Idler Pivot	1	2	50 hours
2. Front Caster Axles (S- and E-Series Only)	1	2	25 hours
2. Front Caster Axles (X-Series)	1	2	Yearly

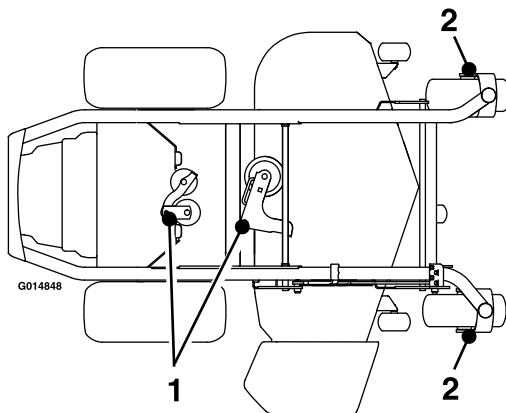

Figure 61

Lubricate Caster Wheel Hubs (X-Series Only)

Service Interval: As required

1. Stop engine, wait for all moving parts to stop, and remove key. Engage parking brake.

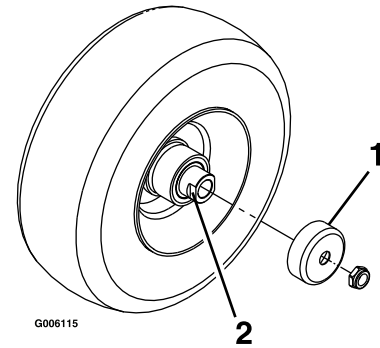

Figure 62

1. Seal guard
 2. Spacer nut with wrench flats
-
2. Remove caster wheel from caster forks.
 3. Remove seal guards from the wheel hub.
 4. Remove one of the spacer nuts from the axle assembly in the caster wheel. Note that thread locking adhesive has been applied to lock the spacer nuts to the axle. Remove the axle (with the other spacer nut still assembled to it) from the wheel assembly.
 5. Pry out seals, and inspect bearings for wear or damage and replace if necessary.
 6. Pack the bearings with a NLGI grade #1 multi-purpose grease.
 7. Insert one bearing, one new seal into the wheel.
- Note:** Seals (Exmark P/N 103-0063) must be replaced.
8. If the axle assembly has had both spacer nuts removed (or broken loose), apply a thread locking adhesive to one spacer nut and thread onto the axle with the wrench flats facing outward. Do Not thread spacer nut all of the way onto the end of the axle. Leave approximately 1/8 inch (3 mm) from the outer surface of the spacer nut to the end of the axle inside the nut.
 9. Insert the assembled nut and axle into the wheel on the side of the wheel with the new seal and bearing.

Maintenance

10. With the open end of the wheel facing up, fill the area inside the wheel around the axle full of NLGI grade #1 multi-purpose grease.
11. Insert the second bearing and new seal into the wheel.
12. Apply a thread locking adhesive to the 2nd spacer nut and thread onto the axle with the wrench flats facing outward.
13. Torque the nut to 75-80 in-lb (8-9 N-m), loosen, then re-torque to 20-25 in-lb (2-3 N-m). Make sure axle does not extend beyond either nut.
14. Reinstall the seal guards over the wheel hub and insert wheel into caster fork. Reinstall caster bolt and tighten nut fully.

Important: To prevent seal and bearing damage, check the bearing adjustment often. Spin the caster tire. The tire should not spin freely (more than 1 or 2 revolutions) or have any side play. If the wheel spins freely, adjust torque on spacer nut until there is a slight amount of drag. Reapply thread locking adhesive.

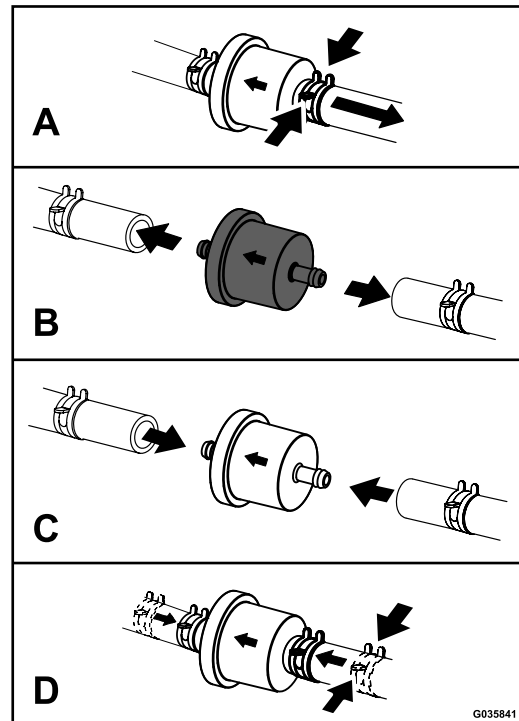

Figure 63

Change Fuel Filter

Service Interval: As required

A fuel filter is installed between the fuel tank and the engine. Replace when necessary.

Replacement Filters	
Exmark	Exmark P/N 133-1563
Kohler	Kohler P/N 24 050 13
Kawasaki	Kawasaki P/N 49019-0014

Note: It is important to reinstall the fuel line hoses and secure with plastic ties the same as they were originally installed at the factory to keep the fuel line away from components that could cause fuel line damage.

1. Stop engine, wait for all moving parts to stop, and remove key or spark plug wire(s). Engage parking brake
2. Squeeze the ends of the hose clamps together and slide them away from the filter.
3. Remove the filter from the fuel lines.
4. Install a new filter with the flow direction arrow coming from the fuel tank and pointing to the engine. Move the hose clamps close to the filter to secure it in place.

Replace Emissions Air Intake Filter (If Applicable)

Service Interval: Every 500 hours

1. Stop engine, wait for all moving parts to stop, and remove key or spark plug wire(s). Engage parking brake.
2. Remove the filter from the vent hose.
3. Insert a new filter into the end of the vent hose.

Change Hydraulic System Filter and Fluid

Service Interval: After the first 75 hours

**Every 500 hours thereafter
(Every 250 hours if using
Mobil 1 15W50 thereafter)
May need more often
under severe conditions.**

1. Stop engine, wait for all moving parts to stop, and allow engine to cool. Remove key and engage parking brake.
2. Locate the two filters under the transmissions. Remove filter guards.
3. Carefully clean area around filters. It is important that no dirt or contamination enter hydraulic system.
4. Unscrew filters to remove and allow oil to drain from drive system.

Important: Before reinstalling new filters, apply a thin coat of Exmark Premium Hydro Oil on the surface of the filters rubber seal.

Turn the filters clockwise until rubber seal contacts the filter adapter then tighten the filter an additional 3/4 to 1 full turn.

5. Loosen the vent plug on each transmission and fill through expansion reservoir, when oil comes out of vent retighten plug.

Exmark Premium Hydro Oil is recommended. Refer to the chart for an acceptable alternative:

Hydro Oil	Service Interval
Exmark Premium Hydro Oil (Preferred)	After first 75 hours *Every 500 hours thereafter
Mobil 1 15W50	After first 75 hours *Every 250 hours thereafter

*May need more often under severe conditions.

Torque plugs to 180 in-lb (244 N-m). Continue to add oil until it reaches the FULL COLD line on the expansion reservoir.

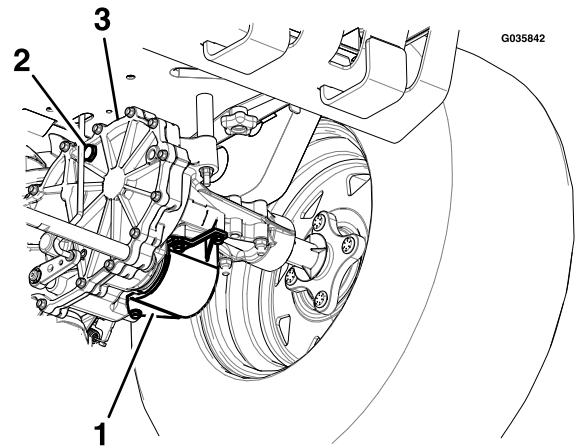

Figure 64
Right side shown

1. Filter guard and oil filter
2. Vent plug
3. Transaxle drive

6. Raise the rear of machine up and support with jack stands (or equivalent support) just high enough to allow drive wheels to turn freely.

CAUTION

Raising the mower deck for service or maintenance relying solely on mechanical or hydraulic jacks could be dangerous. The mechanical or hydraulic jacks may not be enough support or may malfunction allowing the unit to fall, which could cause injury.

Do Not rely solely on mechanical or hydraulic jacks for support. Use adequate jack stands or equivalent support.

7. Start engine and move throttle control ahead to 1/2 throttle position. Disengage parking brake.

WARNING

Engine must be running and drive wheels must be turning so adjustments can be performed. Contact with moving parts or hot surfaces may cause personal injury.

Keep fingers, hands, and clothing clear of rotating components and hot surfaces.

- A. With the bypass valve open and the engine running, slowly move the directional control in both forward and reverse (5 or 6 times).
- B. With the bypass valve closed and the engine running, slowly move the directional control

Maintenance

in both forward and reverse directions (5 to 6 times). Check the oil level, and add oil as required after stopping the engine.

- C. It may be necessary to repeat steps A and B until all the air is completely purged from the system. When the transaxle operates at normal noise levels and moves smoothly forward and reverse at normal speeds, then the transaxle is considered purged.

Note: Do Not change the hydraulic system oil (except for what can be drained when changing filter), unless it is felt the oil has been contaminated or been extremely hot.

Changing oil unnecessarily could damage hydraulic system by introducing contaminants into the system.

Check Spark Arrester (if equipped)

Service Interval: Every 50 hours

▲ WARNING

Hot exhaust system components may ignite gasoline vapors even after the engine is stopped. Hot particles exhausted during engine operation may ignite flammable materials. Fire may result in personal injury or property damage.

Do Not refuel or run engine unless spark arrester is installed.

1. Stop engine, wait for all moving parts to stop, and remove key. Engage parking brake.
2. Wait for muffler to cool.
3. If any breaks in the screen or welds are observed, replace arrester.
4. If plugging of the screen is observed, remove arrester and shake loose particles out of the arrester and clean screen with a wire brush (soak in solvent if necessary). Reinstall arrester on exhaust outlet.

Thread Locking Adhesives

Thread locking adhesives such as “Loctite 242”, “Loctite 243”, or “Fel-Pro, Pro-Lock Nut Type” are used on the following fasteners:

- ROPS spring pin housing

- Sheave and clutch retaining bolt in the end of engine crankshaft.
- Hydro cross member mounting bolts

Thread locking adhesives are required for some hardware on engines — see the Engine manual.

Copper-Based Anti-seize

Copper-based anti-seize is used in the following location:

On threads of Blade Bolts. See **Check Mower Blades** section.

Dielectric Grease

Dielectric grease is used on all blade type electrical connections to prevent corrosion and loss of contact. Dielectric grease should not be applied to sealed connectors.

Adjustments

Note: Disengage PTO, shut off engine, wait for all moving parts to stop, engage parking brake, and remove key before servicing, cleaning, or making any adjustments to the unit.

⚠ CAUTION

Raising the mower deck for service or maintenance relying solely on mechanical or hydraulic jacks could be dangerous. The mechanical or hydraulic jacks may not be enough support or may malfunction allowing the unit to fall, which could cause injury.

Do Not rely solely on mechanical or hydraulic jacks for support. Use adequate jack stands or equivalent support.

Deck Leveling

1. Position the mower on a flat surface.
2. Stop engine, wait for all moving parts to stop, and remove key. Engage parking brake.
3. Check the tire pressure in the drive tires. Proper inflation pressure for tires is 13 psi (90 kPa). Adjust if necessary.
4. Position the transport lock in the latching position.
5. Carefully rotate the blades from side to side.
6. Measure between the outside cutting edges and the flat surface (Figure 65). If both measurements are not within 3/16 inch (5 mm), an adjustment is required; continue with this procedure.

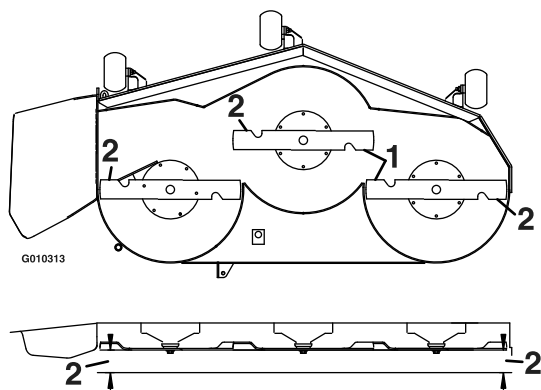

Figure 65

1. Blades side to side
2. Measure here

7. Set anti-scalp rollers to top holes or remove completely for this adjustment.

8. For 60 Inch Decks Only:
 - A. Raise the deck to the transport (5 inch (12.7 cm) cutting height) position.
 - B. Slowly loosen the adjusting screw on the lift assist spring until the screw can be removed (see Figure 66). Save the screw for reinstallation.

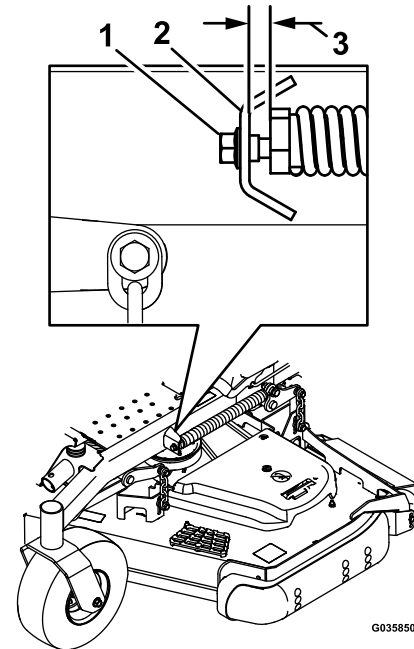

Figure 66

1. Adjusting screw
2. Bracket
3. Set gap to 3/4–7/8 inch (19–22 mm)

9. Set the height-of-cut lever to the 3 inch (76 mm) position. Place two “B” thick blocks (see Block Height and Rake Table) under the rear edge of the cutting deck skirt; one on each side of the cutting deck. Place two “A” thick blocks under each side of the front edge of the deck, but not under the anti-scalp roller brackets.

S and E-Series—Block Height and Rake Table

Deck Size	Front Block Height “A”	Rear Block Height “B”	Rake “R”
48, 52, & 60	2.56 inches (6.5 cm)	2.81 inches (7.1 cm)	1/16–5/16 inch (1.6–7.9 mm)
60R	2.63 inches (6.7 cm)	2.63 inches (6.7 cm)	0–1/8 inch (0–3.2 mm)

Maintenance

X-Series—Block Height and Rake Table

Deck Size	Front Block Height "A"	Rear Block Height "B"	Rake "R"
48, 52, & 60	2.63 inches (6.7 cm)	2.88 inches (7.3 cm)	1/16–5/16 inch (1.6–7.9 mm)

- Carefully rotate the blades side to side (Figure 65).
- Loosen the leveling adjust locking nuts (item 1 Figure 67) on all four corners so that the deck is sitting securely on all four blocks. Make sure that the slack is removed from the deck hangers and the deck lift foot lever is pushed back against the stop, then tighten the four leveling adjust locking nuts.

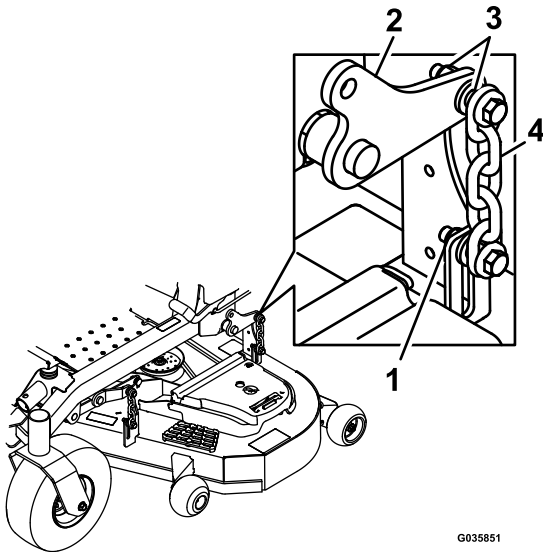

Figure 67

- Leveling adjust locking nuts
- Deck lift arm
- Deck hanger
- Chain

- Recheck that blocks fit just snugly under the deck skirt. Make sure all attachment bolts are tight
- Continue leveling the deck by checking the front-to-rear blade slope; refer to **Adjusting the Blade Slope**.
- Recheck blades for levelness and repeat deck leveling procedure if necessary.
- For 60 Inch Decks Only:
 - Raise the deck to the transport (5 inch (12.7 cm) cutting height) position.
 - Reinstall the lift assist spring adjusting screw that was removed in step 8.

- Set the gap between the spring and bracket to 3/4–7/8 inch (19–22 mm).

Adjusting the Blade Slope

- Check the front-to-rear blade level. If the front blade tip is not "R" (see Block Height and Rake Table in **Deck Leveling**) lower than the rear blade tip, adjust the blade level using the following instructions:
- Park the machine on a level surface and disengage the blade control switch.
- Move the motion control levers outward to the neutral position, engage the parking brake, stop the engine, remove the key, and wait for all moving parts to stop before leaving the operating position.
- Check the air pressure of all four tires. If needed, adjust to the recommended inflation; refer to **Checking the Tire Pressure** in Drive System Maintenance section.
- Check and adjust the side-to-side blade level if you have not checked the setting; refer to **Deck Leveling**.
- Set the height-of-cut lever to the 3 inch (76 mm) position. Place two "B" thick blocks (see Block Height and Rake Table in **Deck Leveling**) under the rear edge of the cutting deck skirt; one on each side of the cutting deck. Place two "A" thick blocks (see Block Height and Rake Table in **Deck Leveling**) under each side of the front edge of the deck, but not under the anti-scalp roller brackets.
- Loosen the leveling adjust locking nuts (item 1 Figure 67) on all four corners so that the deck is sitting securely on all four blocks. Make sure that the slack is removed from the deck hangers and the deck lift foot lever is pushed back against the stop, then tighten the four leveling adjust locking nuts.
- Carefully rotate the blades so they are facing front to rear (Figure 68).
- For 60 Inch Decks Only:
 - Raise the deck to the transport (5 inch (12.7 cm) cutting height) position.
 - Slowly loosen the adjusting screw on the lift assist spring until the screw can be

removed (see Figure 66). Save the screw for reinstallation.

- Measure from the tip of the front blade to the flat surface and the tip of the rear blade to the flat surface (Figure 68). If the front blade tip is not “R” (see Block Height and Rake Table in **Deck Leveling**) lower than the rear blade tip, adjust the front deck hanger.

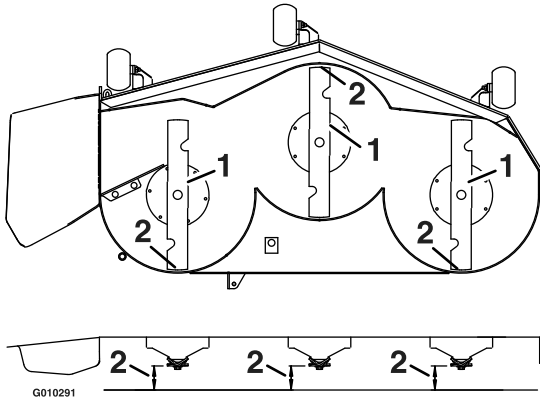

Figure 68

- Blades front to rear
- Measure here

- When the front-to-rear blade slope is correct check the side-to-side level of the mower again; refer to **Deck Leveling**.
- For 60 Inch Decks Only:
 - Raise the deck to the transport (5 inch (12.7 cm) cutting height) position.
 - Reinstall the lift assist spring adjusting screw that was removed in step 9.
 - Set the gap between the spring and bracket to 3/4–7/8 inch (19–22 mm) (see Figure 66).

Pump Drive Belt Tension

Self-tensioning - No adjustment necessary.

Deck Belt Tension

Self-tensioning - No adjustment necessary.

Adjusting the Parking Brake

Service Interval: Every 500 hours

Check to make sure brake is adjusted properly. This procedure must be followed after the first 100 hours or when a brake component has been removed or replaced.

- Drive the machine onto a level surface.
- Disengage the blade control switch (PTO), move the motion control levers to the neutral locked position and set the parking brake.
- Stop the engine, wait for all moving parts to stop, and remove the key.
- Setup the machine to be pushed by hand (see **Drive Wheel Release Valves** in the Operation section).
- Raise the back of the machine up and support the machine with jack stands.

CAUTION

Raising the mower deck for service or maintenance relying solely on mechanical or hydraulic jacks could be dangerous. The mechanical or hydraulic jacks may not be enough support or may malfunction allowing the unit to fall, which could cause injury.

Do Not rely solely on mechanical or hydraulic jacks for support. Use adequate jack stands or equivalent support.

- Engage/disengage the brake and check each drive tire to make sure each brake engages/disengages.
- If adjustment is necessary, disengage the park brake. Remove cotter pin from the brake linkage shaft (see Figure 69).

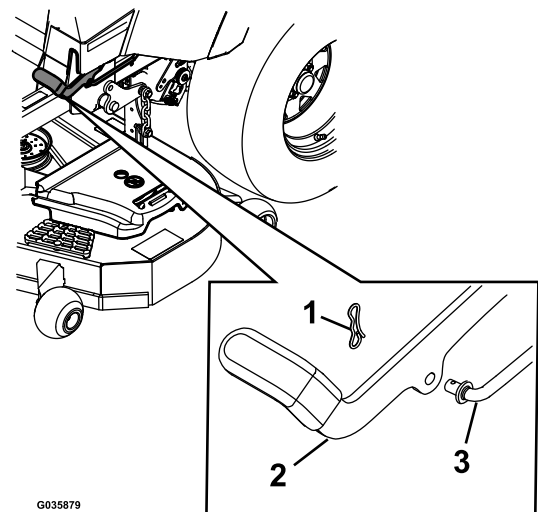

Figure 69

- Cotter pin
- Parking brake
- Brake linkage shaft

- Check the both spring lengths as shown in Figure 70. If adjustment is necessary, turn the top

Maintenance

nut clockwise to shorten and counterclockwise to lengthen.

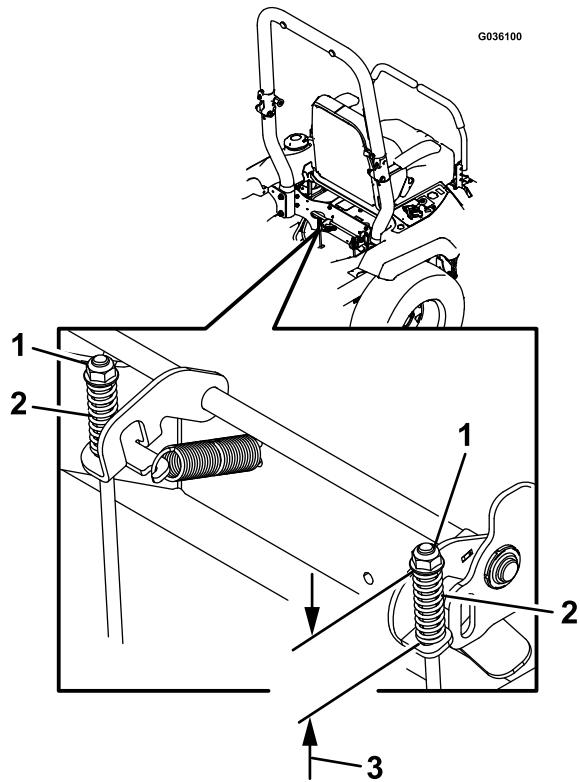

Figure 70

1. Top nut
2. Spring
3. 1.75 inches (44 mm)

9. Push the parking brake lever all the way forward and down. Rotate the brake linkage shaft until the end aligns with hole in lever.

- Shorten the linkage by turning it clockwise.
- Lengthen the linkage by turning it counterclockwise.

Insert the brake linkage shaft into parking brake hole and secure with the cotter pin. Repeat step 6 and readjust if necessary.

10. When adjustment is complete, remove the jack stands or equivalent support and lower the machine.

11. Place the machine into the “operating” position. Refer to the **Drive Wheel Release Valves** section in Operation.

Motion Control Handle Adjustment

Adjusting the height:

The motion control levers can be adjusted higher or lower for maximum operator comfort.

1. Remove the hardware holding the control lever to the control arm shaft.

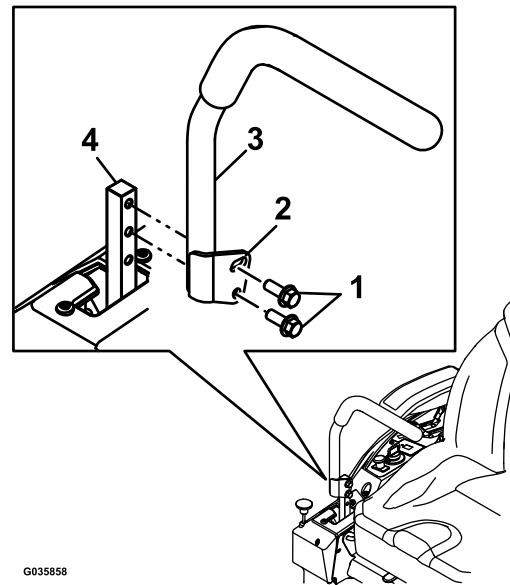

Figure 71

1. Bolts
2. Slotted hole
3. Control lever
4. Control arm shaft

2. Move the control lever to the next set of holes. Secure the lever with the hardware.
3. Repeat the adjustment for the opposite control lever.

Adjusting the Tilt

The motion control levers can be tilted fore or aft for maximum operator comfort.

1. Loosen the upper bolt holding the control lever to the control arm shaft.
2. Loosen the lower bolt just enough to pivot the control lever fore or aft. Tighten both bolts to secure the control in the new position.
3. Repeat the adjustment for the opposite control lever.

Full Forward Tracking Adjustment

If the machine travels or pulls to one side, when the motion control levers are in the full forward position, adjust the tracking screw.

1. Insert a 3/16 inch hex wrench through the access hole on the front cover panel, rotate the tracking

screw clockwise or counterclockwise to adjust the travel of the lever.

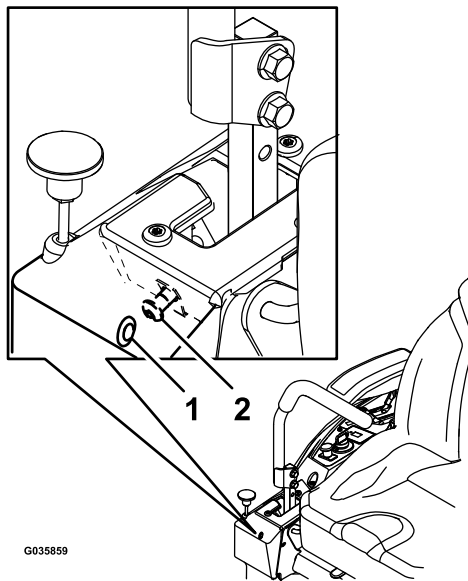

Figure 72

1. Access hole on front cover panel
2. Tracking screw

2. Drive the machine and check the full forward tracking.
3. Repeat steps 1 and 2 until desired tracking is obtained.

Motion Control Linkage Adjustment

Located on either side of the unit, below the seat are the pump control linkages. Rotating the end nut with a 1/2 inch deep socket wrench allows fine tuning adjustments so that the machine does not move in neutral. Any adjustments should be made for neutral positioning only.

⚠ WARNING

Engine must be running and drive wheels must be turning so adjustments can be performed. Contact with moving parts or hot surfaces may cause personal injury.

Keep fingers, hands, and clothing clear of rotating components and hot surfaces.

1. Prior to starting the engine, push the deck lift pedal and remove the height of cut pin. Lower deck to the ground.

2. Raise the rear of machine up and support with jack stands (or equivalent support) just high enough to allow drive wheels to turn freely.
3. Remove the electrical connection from the seat safety switch, located under the bottom cushion of the seat. The switch is a part of the seat assembly.
4. **Temporarily** install a jumper wire across the terminals in the connector of the main wiring harness.
5. Start engine. **Brake must be engaged and motion control levers out to start engine. Operator does not have to be in the seat.** Run engine at full throttle and release brake.
6. Run the unit at least 5 minutes with the drive levers at full forward speed to bring hydraulic oil up to operating temperature.

Note: The motion control lever needs to be in neutral while making any necessary adjustments.

7. Bring the motion control levers into the neutral position. The control plate tabs should touch the return to neutral plates on the hydros. Adjust pump control rod lengths by turning the nut in the appropriate direction until the wheels slightly creep in reverse (see Figure 73). Move the motion control levers to the reverse position and while applying slight pressure to the lever allow the reverse indicator springs to bring the levers back to neutral. The wheels must stop turning or slightly creep in reverse.

The motion control cover may need to be removed to gain access.

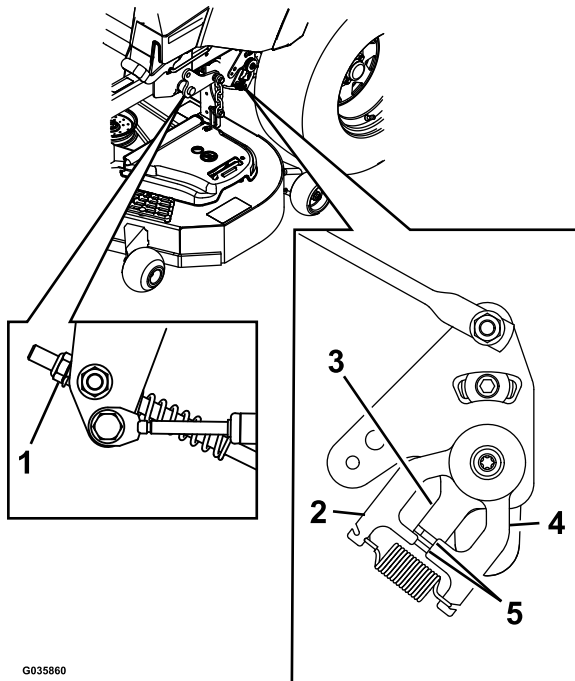

Figure 73

1. Nut
2. Stationary plate
3. Control plate
4. Return to neutral plate
5. Tabs touching return to neutral plate

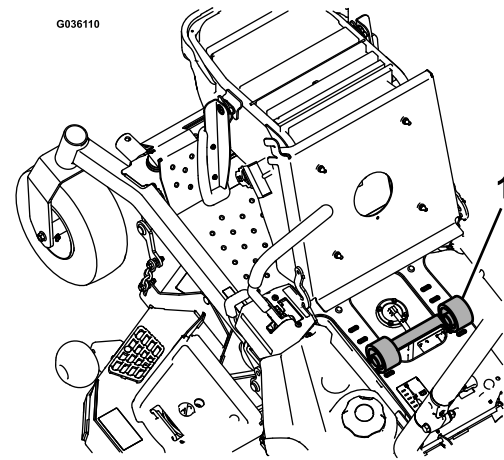

Figure 74

1. Seat isolator

Electric Clutch Adjustment

No adjustment necessary.

8. Shut off unit. Remove jumper wire from wire harness and plug connector into seat switch.
9. Remove the jack stands.
10. Raise the deck and re-install the height of cut pin.
11. Check that the machine does not creep in neutral with the park brake disengaged.

Adjusting the Seat Ride Suspension S-Series Only

The seat isolator can be changed to maximize rider comfort (see Figure 74).

- For a firmer ride, move the seat isolator rearward.
 - used for operators 200 lb (91 kg) and over
 - mowing rough terrain
- For a softer ride, move the seat isolator forward.
 - used for operators less than 200 lb (91 kg)
 - mowing smooth, well established lawns

Cleaning

Clean Engine and Exhaust System Area

Service Interval: Before each use or daily (May be required more often in dry or dirty conditions.)

⚠ CAUTION

Excessive debris around engine cooling air intake and exhaust system area can cause engine, exhaust area, and hydraulic system to overheat which can create a fire hazard.

Clean all debris from engine and exhaust system area.

1. Stop engine, wait for all moving parts to stop, and remove key. Engage parking brake.
2. Clean all debris from rotating engine air intake screen, around engine shrouding, and exhaust system area.
3. Wipe up any excessive grease or oil around the engine and exhaust system area.

Remove Engine Shrouds and Clean Cooling Fins

Service Interval: Every 100 hours

1. Stop engine, wait for all moving parts to stop, and remove key. Engage parking brake.
2. Remove cooling shrouds from engine and clean cooling fins. Also clean dust, dirt and oil from external surfaces of engine which can cause inadequate cooling.
3. Make sure cooling shrouds are reinstalled. Operating the engine without cooling shrouds will cause engine damage due to overheating.

Clean Debris From Machine

Service Interval: Before each use or daily

1. Stop engine, wait for all moving parts to stop, and remove key. Engage parking brake.
2. Clean off any oil, debris, or grass build-up on the machine and cutting deck, especially under deck

belt shields, around the fuel tank, around engine and exhaust area, and around hydro fans.

Clean Grass Build-Up Under Deck

Service Interval: Before each use or daily

1. Park the machine on a level surface and disengage the blade control switch.
2. Stop engine, wait for all moving parts to stop, and remove key. Engage parking brake.
3. Raise deck to the transport (5 inch (12.7 cm) cutting height) position. Lift the front of unit and support unit using jack stands or equivalent support.

⚠ CAUTION

Raising the mower deck for service or maintenance relying solely on mechanical or hydraulic jacks could be dangerous. The mechanical or hydraulic jacks may not be enough support or may malfunction allowing the unit to fall, which could cause injury.

Do Not rely solely on mechanical or hydraulic jacks for support. Use adequate jack stands or equivalent support.

4. Clean out any grass build-up from underside of deck and in discharge deflector.

Waste Disposal

Motor Oil Disposal

Engine oil and hydraulic oil are both pollutants to the environment. Dispose of used oil at a certified recycling center or according to your state and local regulations.

Battery Disposal

⚠ DANGER

Battery electrolyte contains sulfuric acid, which is poisonous and can cause severe burns.

Swallowing electrolyte can be fatal or if it touches skin can cause severe burns.

- **Wear safety glasses to shield eyes, and rubber gloves to protect skin and clothing when handling electrolyte.**
- **Do Not swallow electrolyte.**
- **In the event of an accident, flush with water and call a doctor immediately.**

Federal law states that batteries should not be placed in the garbage. Management and disposal practices must be within relevant federal, state, or local laws.

If a battery is being replaced or if the unit containing the battery is no longer operating and is being scrapped, take the battery to a local certified recycling center. If no local recycling is available return the battery to any certified battery reseller.

Troubleshooting

Important: It is essential that all operator safety mechanisms be connected and in proper operating condition prior to mower use.

When a problem occurs, do not overlook the simple causes. For example: starting problems could be caused by an empty fuel tank.

The following table lists some of the common causes of trouble. Do not attempt to service or replace major items or any items that call for special timing of adjustment procedures (such as valves, governor, etc.). Have this work done by your **Engine Service Dealer**.

Note: When disconnecting electrical connectors DO NOT pull on the wires to separate the connectors.

Problem	Possible Cause	Corrective Action
Starter does not crank	<ol style="list-style-type: none"> 1. PTO is engaged. 2. Parking brake is not engaged. 3. Drive levers are not in neutral lock position. 4. Battery does not have a full charge. 5. Electrical connections are corroded, loose or faulty. 6. Fuse is blown. 7. Relay or switch is defective. 8. Faulty module. 	<ol style="list-style-type: none"> 1. Disengage the PTO. 2. Set the parking brake. 3. Ensure the drive levers are in the neutral lock position. 4. Charge the battery. See Check Battery Charge and Recommended Jump Starting Procedure sections in Maintenance. 5. Check the electrical connections for good contact. Clean connector terminals thoroughly with electrical contact cleaner, apply dielectric grease and reconnect. 6. Replace the blown fuse. 7. Contact an Authorized Service Dealer. 8. Replace module.
Engine will not start, starts hard, or fails to keep running	<ol style="list-style-type: none"> 1. Fuel tank is empty. 2. Fuel shutoff valve is closed. 3. Oil level in the crankcase is low. 4. The throttle and choke are not in the correct position. 5. Dirt in fuel filter. 6. Dirt, water, or stale fuel is in the fuel system. 7. Air cleaner is dirty. 8. Seat switch is not functioning properly. 9. Electrical connections are corroded, loose or faulty. 10. Relay or switch is defective. 11. Faulty spark plug. 12. Spark plug wire is not connected. 13. Faulty module. 	<ol style="list-style-type: none"> 1. Fill the fuel tank. 2. Open the fuel shutoff valve. 3. Add oil to the crankcase. 4. Be sure the throttle control is midway between the "SLOW" and "FAST" positions, and the choke is in the "ON" position for a cold engine or the "OFF" position for a warm engine. 5. Replace the fuel filter. 6. Contact an Authorized Service Dealer. 7. Clean or replace the air cleaner element. 8. Check the seat switch indicator. Replace seat if needed. 9. Check the electrical connections for good contact. Clean connector terminals thoroughly with electrical contact cleaner, apply dielectric grease and reconnect. 10. Contact an Authorized Service Dealer. 11. Clean, adjust or replace spark plug. 12. Check the spark plug wire connection. 13. Replace module.

Troubleshooting

Problem	Possible Cause	Corrective Action
Engine loses power	<ol style="list-style-type: none"> 1. Engine load is excessive 2. Air cleaner is dirty. 3. Oil level in the crankcase is low. 4. Cooling fins and air passages for the engine are plugged. 5. Dirt in fuel filter. 6. Dirt, water, or stale fuel is in the fuel system. 	<ol style="list-style-type: none"> 1. Reduce the ground speed. 2. Clean or replace the air cleaner element. 3. Add oil to the crankcase. 4. Remove the obstructions from the cooling fins and air passages. 5. Replace the fuel filter. 6. Contact an Authorized Service Dealer.
Mower pulls left or right (with levers fully forward)	<ol style="list-style-type: none"> 1. Tire pressure in drive tires not correct. 	<ol style="list-style-type: none"> 1. Adjust tire pressure in the drive tires.
Machine does not drive	<ol style="list-style-type: none"> 1. Drive release handle not in "operating" position. 2. Drive or pump belt is worn, loose or broken. 3. Drive or pump belt is off a pulley. 4. Broken or missing idler spring. 5. Hydraulic fluid level is low or too hot. 	<ol style="list-style-type: none"> 1. Position handle in "operating" position; see Drive Wheel Release Valves section in Operation. 2. Change the belt. 3. Change the belt. 4. Replace the spring. 5. Add hydraulic fluid to reservoir or let it cool down.
Uneven cutting height.	<ol style="list-style-type: none"> 1. Blade(s) not sharp. 2. Cutting blade(s) is/are bent. 3. Mower deck is not level. 4. Underside of mower is dirty. 5. Tire pressure in drive tires not correct. 6. Blade spindle bent. 7. Tips of adjacent blades are at an uneven cutting height. Blades tips should be even within 3/16 inch which is approximately one blade thickness. 	<ol style="list-style-type: none"> 1. Sharpen the blade(s). 2. Install new cutting blade(s). 3. Level mower deck from side-to-side and front-to-rear. 4. Clean the underside of the mower. 5. Adjust tire pressure in the drive tires. 6. Contact an Authorized Service Dealer. 7. Replace blades, spindles and (or) check for damage to mower deck.
Abnormal vibration	<ol style="list-style-type: none"> 1. Cutting blade(s) is/are bent or unbalanced. 2. Blade mounting bolt is loose. 3. Engine mounting bolts are loose. 4. Loose engine pulley, idler pulley, or blade pulley. 5. Engine pulley is damaged. 6. Blade spindle is bent. 	<ol style="list-style-type: none"> 1. Install new cutting blade(s). 2. Tighten the blade mounting bolt. 3. Tighten the engine mounting bolts. 4. Tighten the appropriate pulley. 5. Contact an Authorized Service Dealer. 6. Contact an Authorized Service Dealer.
Blades do not rotate.	<ol style="list-style-type: none"> 1. Drive belt is worn, loose or broken. 2. Deck belt is worn, loose or broken. 3. Deck belt is off pulley. 4. Broken or missing idler spring. 5. Drive belt not routed correctly. 	<ol style="list-style-type: none"> 1. Check the belt tension. 2. Install new deck belt. 3. Install belt on clutch and deck pulleys, idlers, and tensioning idler per routing decal on deck. 4. Replace the spring. 5. Refer to belt routing decal on deck.

Schematics

Electrical Logic Schematic — Exmark Engine

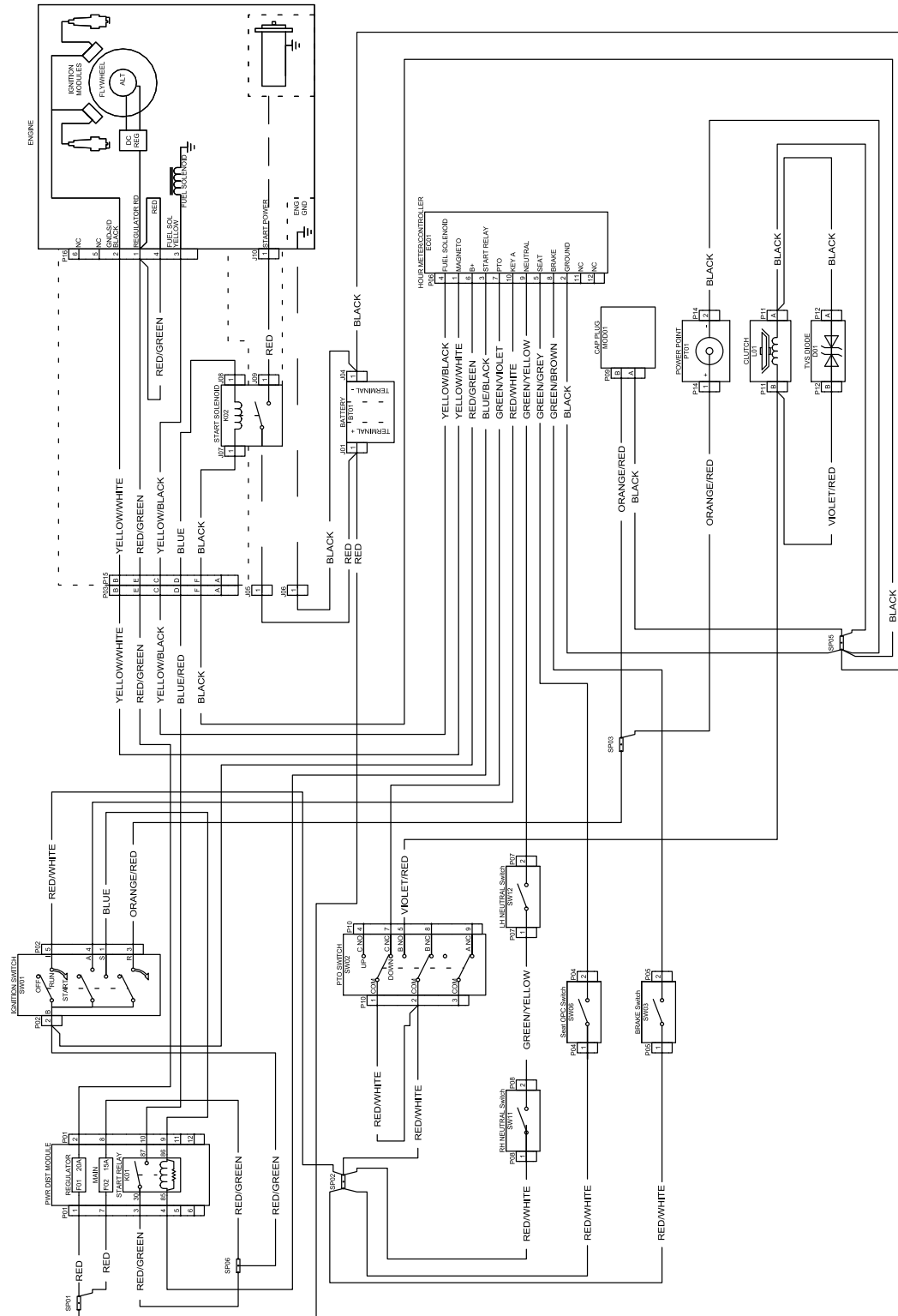

G038150

Electrical Logic Schematic — Kohler Engine

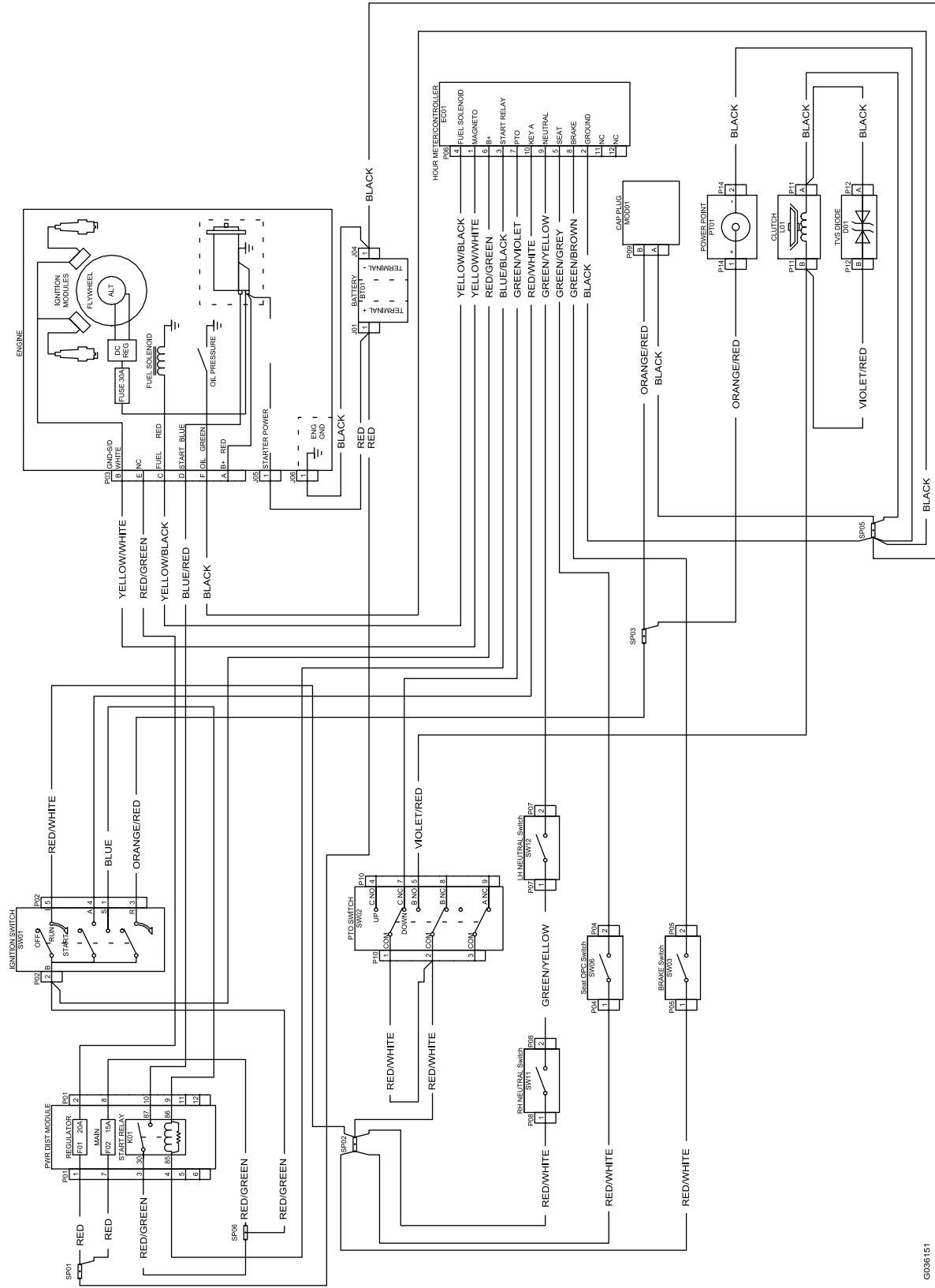

G038151

Electrical Logic Schematic — Kawasaki Engine

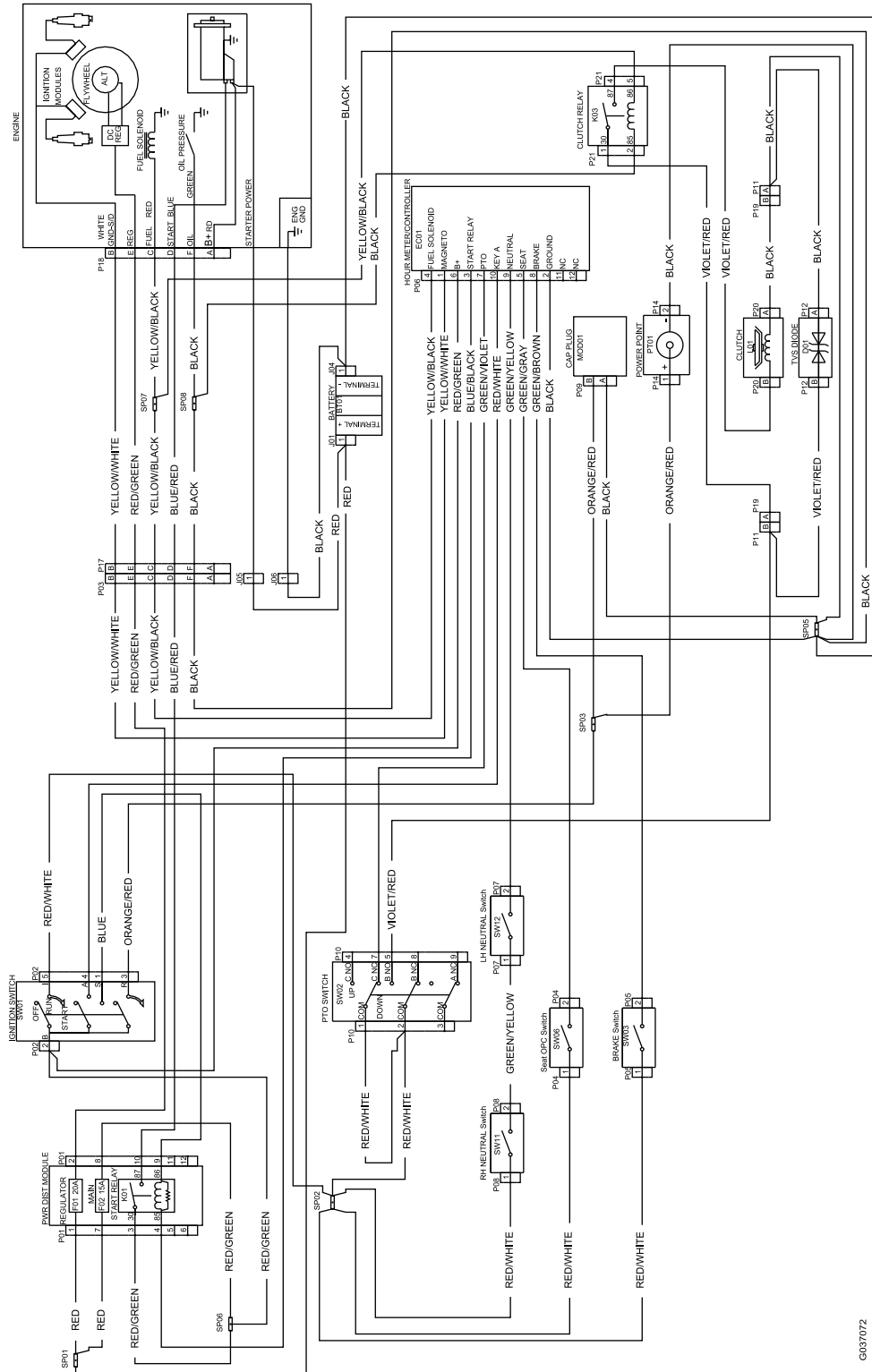

G037072

Exmark Radius E-Series Turf Equipment

4 Year or 500 Hours Limited Warranty

General Warranty Conditions and Products Covered

Exmark Mfg. Co. Inc. and its affiliate, Exmark Warranty Company, pursuant to an agreement between them, jointly warrant on the terms and conditions herein, that we will repair, replace or adjust any part on these products and found by us (in the exercise of our reasonable discretion) to be defective in factory materials or workmanship.

This warranty may only be assigned or transferred to a second (or third) owner by an authorized Exmark dealer. The warranty period commences upon the date of the original retail purchase.

Warranty Conditions

This warranty applies to Exmark Radius E-Series turf equipment sold in the U.S. or Canada for a period of four years or 500 hours (whichever occurs first).

This warranty only includes the cost of parts and labor. For the first warrantable service repair, Exmark will cover up to \$45 for associated pick-up and delivery charges to and from any authorized Exmark Service Dealer. Additional transportation charges may apply, contact your Dealer for details.

Warranty Exceptions

<u>Warranty Exceptions</u>	<u>Warranty Period</u>
• Battery	1 Year - \$45 Reimbursement Fee

Items and Conditions Not Covered

This warranty does not cover the following:

- Any damage or deterioration due to normal use, wear and tear, or exposure.
- Cost of regular maintenance service or parts, such as filters, fuel, lubricants, tune-up parts, and adjustments.
- Any product or part which has been altered or misused or required replacement or repair due to normal wear, accidents, or lack of proper maintenance as set forth in the maintenance section of the operator's manual.
- Any repairs necessary due to use of parts, accessories or supplies, including gasoline, oil or lubricants, incompatible with the turf equipment or other than as recommended in the operator's manual or other operational instructions provided by Exmark.

There are no other express warranties except for special emission system coverage. For details, see the emissions system warranty statements included with your product.

All warranty work must be performed by an authorized Exmark Service Dealer using Exmark approved replacement parts.

Instructions for Obtaining Warranty Service

The product must be registered with original proof of purchase by an Exmark Service Dealer before obtaining any warranty service.

Contact any Exmark Service Dealer to arrange service at their dealership. To locate a dealer convenient to you, access our website at www.exmark.com. U.S. or Canada customers may also call 402-223-6375.

If for any reason you are dissatisfied with the Service Dealer's analysis or with the assistance provided, contact us at:

Exmark Customer Service Department
The Exmark Warranty Company
2101 Ashland Avenue
Beatrice, NE 68310
402-223-6375 or
service@exmark.com

Owner's Responsibilities

If your product requires warranty service it must be returned to an authorized Exmark service dealer within the warranty period. This warranty extends only to turf equipment operated under normal conditions. You must read the operator's manual. You must also properly service and maintain your Exmark product as described in the operator's manual. Such routine maintenance, whether performed by a dealer or by you, is at your expense.

General Conditions

The sole liability of Exmark and Exmark Warranty Company with respect to this warranty shall be repair or replacement of defective components as set forth herein. **Neither Exmark nor Exmark Warranty Company shall be liable for any incidental or consequential loss or damage.**

Such damages include but are not limited to:

- Expenses related to gasoline, oil or lubricants.
- Travel time, overtime, after hours time or other extraordinary repair charges or charges relating to repairs or replacements outside of normal business hours at the place of business of the authorized Exmark Service Dealer.
- Rental of like or similar replacement equipment during the period of any warranty, repair or replacement work.
- Any telephone or telegram charges or travel charges.
- Loss or damage to person or property other than that covered by the terms of this warranty.
- Any claims for lost revenue, lost profit or additional cost as a result of a claim of breach of warranty.
- Attorney's fees.

No Claim of breach of warranty shall be cause for cancellation or rescission of the contract of sale of any Exmark mower.

All implied warranties of merchantability (that the product is fit for ordinary use) and fitness for use (that the product is fit for a particular purpose) are limited to the duration of the express warranty.

Some states do not allow exclusions of incidental or consequential damages, or limitations on how long an implied warranty lasts, so the above exclusions and limitations may not apply to you.

This warranty gives you specific legal rights, and you may also have other rights which vary from state to state.

G4502-955_C

Exmark Radius S-Series Turf Equipment

4 Year or 750 Hours Limited Warranty

General Warranty Conditions and Products Covered

Exmark Mfg. Co. Inc. and its affiliate, Exmark Warranty Company, pursuant to an agreement between them, jointly warrant on the terms and conditions herein, that we will repair, replace or adjust any part on these products and found by us (in the exercise of our reasonable discretion) to be defective in factory materials or workmanship.

This warranty may only be assigned or transferred to a second (or third) owner by an authorized Exmark dealer. The warranty period commences upon the date of the original retail purchase.

Warranty Conditions

This warranty applies to Exmark Radius S-Series turf equipment sold in the U.S. or Canada for a period of four years or 750 hours (whichever occurs first).

This warranty only includes the cost of parts and labor. For the first warrantable service repair, Exmark will cover up to \$45 for associated pick-up and delivery charges to and from any authorized Exmark Service Dealer. Additional transportation charges may apply, contact your Dealer for details.

Warranty Exceptions

<u>Warranty Exceptions</u>	<u>Warranty Period</u>
• Bags, Belts and Tires	500 hours
• Battery	1 Year - \$45 Reimbursement Fee
• Engine	*

* The Engine warranty is covered by the engine manufacturer. Please refer to the engine manufacturer's warranty and emissions system warranty included in the literature packet.

Items and Conditions Not Covered

This warranty does not cover the following:

- Any damage or deterioration due to normal use, wear and tear, or exposure.
- Cost of regular maintenance service or parts, such as filters, fuel, lubricants, tune-up parts, and adjustments.
- Any product or part which has been altered or misused or required replacement or repair due to normal wear, accidents, or lack of proper maintenance as set forth in the maintenance section of the operator's manual.
- Any repairs necessary due to use of parts, accessories or supplies, including gasoline, oil or lubricants, incompatible with the turf equipment or other than as recommended in the operator's manual or other operational instructions provided by Exmark.

There are no other express warranties except for engine and special emission system coverage.

All warranty work must be performed by an authorized Exmark Service Dealer using Exmark approved replacement parts.

Instructions for Obtaining Warranty Service

The product must be registered with original proof of purchase by an Exmark Service Dealer before obtaining any warranty service.

Contact any Exmark Service Dealer to arrange service at their dealership. To locate a dealer convenient to you, access our website at www.exmark.com. U.S. or Canada customers may also call 402-223-6375.

If for any reason you are dissatisfied with the Service Dealer's analysis or with the assistance provided, contact us at:

Exmark Customer Service Department
The Exmark Warranty Company
2101 Ashland Avenue
Beatrice, NE 68310
402-223-6375 or
service@exmark.com

Owner's Responsibilities

If your product requires warranty service it must be returned to an authorized Exmark service dealer within the warranty period. This warranty extends only to turf equipment operated under normal conditions. You must read the operator's manual. You must also properly service and maintain your Exmark product as described in the operator's manual. Such routine maintenance, whether performed by a dealer or by you, is at your expense.

General Conditions

The sole liability of Exmark and Exmark Warranty Company with respect to this warranty shall be repair or replacement of defective components as set forth herein. **Neither Exmark nor Exmark Warranty Company shall be liable for any incidental or consequential loss or damage.**

Such damages include but are not limited to:

- Expenses related to gasoline, oil or lubricants.
- Travel time, overtime, after hours time or other extraordinary repair charges or charges relating to repairs or replacements outside of normal business hours at the place of business of the authorized Exmark Service Dealer.
- Rental of like or similar replacement equipment during the period of any warranty, repair or replacement work.
- Any telephone or telegram charges or travel charges.
- Loss or damage to person or property other than that covered by the terms of this warranty.
- Any claims for lost revenue, lost profit or additional cost as a result of a claim of breach of warranty.
- Attorney's fees.

No Claim of breach of warranty shall be cause for cancellation or rescission of the contract of sale of any Exmark mower.

All implied warranties of merchantability (that the product is fit for ordinary use) and fitness for use (that the product is fit for a particular purpose) are limited to the duration of the express warranty.

Some states do not allow exclusions of incidental or consequential damages, or limitations on how long an implied warranty lasts, so the above exclusions and limitations may not apply to you.

This warranty gives you specific legal rights, and you may also have other rights which vary from state to state.

G4502-956_C

Exmark Radius X-Series Turf Equipment 4 Year or 1,000 Hours Limited Warranty

General Warranty Conditions and Products Covered

Exmark Mfg. Co. Inc. and its affiliate, Exmark Warranty Company, pursuant to an agreement between them, jointly warrant on the terms and conditions herein, that we will repair, replace or adjust any part on these products and found by us (in the exercise of our reasonable discretion) to be defective in factory materials or workmanship.

This warranty may only be assigned or transferred to a second (or third) owner by an authorized Exmark dealer. The warranty period commences upon the date of the original retail purchase.

Warranty Conditions

This warranty applies to Exmark Radius X-Series turf equipment sold in the U.S. or Canada for a period of four years or 1,000 hours (whichever occurs first).

This warranty only includes the cost of parts and labor. For the first warrantable service repair, Exmark will cover up to \$45 for associated pick-up and delivery charges to and from any authorized Exmark Service Dealer. Additional transportation charges may apply, contact your Dealer for details.

Warranty Exceptions

<u>Warranty Exceptions</u>	<u>Warranty Period</u>
• Bags, Belts and Tires	500 hours
• Battery	1 Year - \$45 Reimbursement Fee
• Engine	*

* The Engine warranty is covered by the engine manufacturer. Please refer to the engine manufacturer's warranty and emissions system warranty included in the literature packet.

Items and Conditions Not Covered

This warranty does not cover the following:

- Any damage or deterioration due to normal use, wear and tear, or exposure.
- Cost of regular maintenance service or parts, such as filters, fuel, lubricants, tune-up parts, and adjustments.
- Any product or part which has been altered or misused or required replacement or repair due to normal wear, accidents, or lack of proper maintenance as set forth in the maintenance section of the operator's manual.
- Any repairs necessary due to use of parts, accessories or supplies, including gasoline, oil or lubricants, incompatible with the turf equipment or other than as recommended in the operator's manual or other operational instructions provided by Exmark.

There are no other express warranties except for engine and special emission system coverage.

All warranty work must be performed by an authorized Exmark Service Dealer using Exmark approved replacement parts.

Instructions for Obtaining Warranty Service

The product must be registered with original proof of purchase by an Exmark Service Dealer before obtaining any warranty service.

Contact any Exmark Service Dealer to arrange service at their dealership. To locate a dealer convenient to you, access our website at www.exmark.com. U.S. or Canada customers may also call 402-223-6375.

If for any reason you are dissatisfied with the Service Dealer's analysis or with the assistance provided, contact us at:

Exmark Customer Service Department
The Exmark Warranty Company
2101 Ashland Avenue
Beatrice, NE 68310
402-223-6375 or
service@exmark.com

Owner's Responsibilities

If your product requires warranty service it must be returned to an authorized Exmark service dealer within the warranty period. This warranty extends only to turf equipment operated under normal conditions. You must read the operator's manual. You must also properly service and maintain your Exmark product as described in the operator's manual. Such routine maintenance, whether performed by a dealer or by you, is at your expense.

General Conditions

The sole liability of Exmark and Exmark Warranty Company with respect to this warranty shall be repair or replacement of defective components as set forth herein. **Neither Exmark nor Exmark Warranty Company shall be liable for any incidental or consequential loss or damage.**

Such damages include but are not limited to:

- Expenses related to gasoline, oil or lubricants.
- Travel time, overtime, after hours time or other extraordinary repair charges or charges relating to repairs or replacements outside of normal business hours at the place of business of the authorized Exmark Service Dealer.
- Rental of like or similar replacement equipment during the period of any warranty, repair or replacement work.
- Any telephone or telegram charges or travel charges.
- Loss or damage to person or property other than that covered by the terms of this warranty.
- Any claims for lost revenue, lost profit or additional cost as a result of a claim of breach of warranty.
- Attorney's fees.

No Claim of breach of warranty shall be cause for cancellation or rescission of the contract of sale of any Exmark mower.

All implied warranties of merchantability (that the product is fit for ordinary use) and fitness for use (that the product is fit for a particular purpose) are limited to the duration of the express warranty.

Some states do not allow exclusions of incidental or consequential damages, or limitations on how long an implied warranty lasts, so the above exclusions and limitations may not apply to you.

This warranty gives you specific legal rights, and you may also have other rights which vary from state to state.

G4502-957_C

Notes:

Notes:



MAXIMIZE THE PERFORMANCE OF YOUR EXMARK MACHINE.



EXMARK® PREMIUM ENGINE OIL

Exmark now offers a family of engine oil viscosities to perform well in any environment. Each viscosity has the same synthetic formulation to give you what you need in punishing conditions. We designed each grade to the highest quality, making it ideal even for diesel applications. Coupled with Exmark Premium Fuel Treatment, we have the performance products to make your machine hum.

EXMARK PREMIUM ENGINE OIL SAE 30/10W-30

- Meets zero shear requirements of a straight grade SAE 30 as well as the cold temp properties of a 10W-30.
- Most versatile oil in the industry.
- Superior corrosion protection over conventional oil - even in corrosive, humid environments.

EXMARK PREMIUM ENGINE OIL SAE 20W-50

- Perfect for your big block engine, or any application in severe service.
- Same full synthetic formulation as all other Exmark Premium viscosities.
- Also effective for use in severe service small block engines.

EXMARK PREMIUM ENGINE OIL SAE 10W-50

- Full synthetic formulation gives you peak performance. Don't settle for less.
- Wide span multi-grade combines easy starting in cold weather with maximum protection in high temperature operation.
- Reduce friction & wear over standard mineral formulations.

EXMARK PREMIUM ENGINE OIL SAE 0W-40

- The perfect choice for when the weather turns cold or unpredictable, and your Exmark UTV has to perform.
- Commercial quality for severe service.
- Advanced additive package helps prevent corrosion from long-term storage.

EXMARK PREMIUM ENGINE OIL UTV FORMULATION

- 4-cycle high-temp formulation.
- Heavier viscosity, full synthetic, perfect for your UTV.

EXMARK PREMIUM UTV EXTREME CONDITIONS GEAR OIL

- SAE 80W-90, designed to keep your UTV performing at its peak.
- Shear stable, hypoid gear lube.
- Includes a premium additive system to combat wear, oxidation, rust & corrosion.

Available from your local Exmark dealer. Find your closest dealer at exmark.com

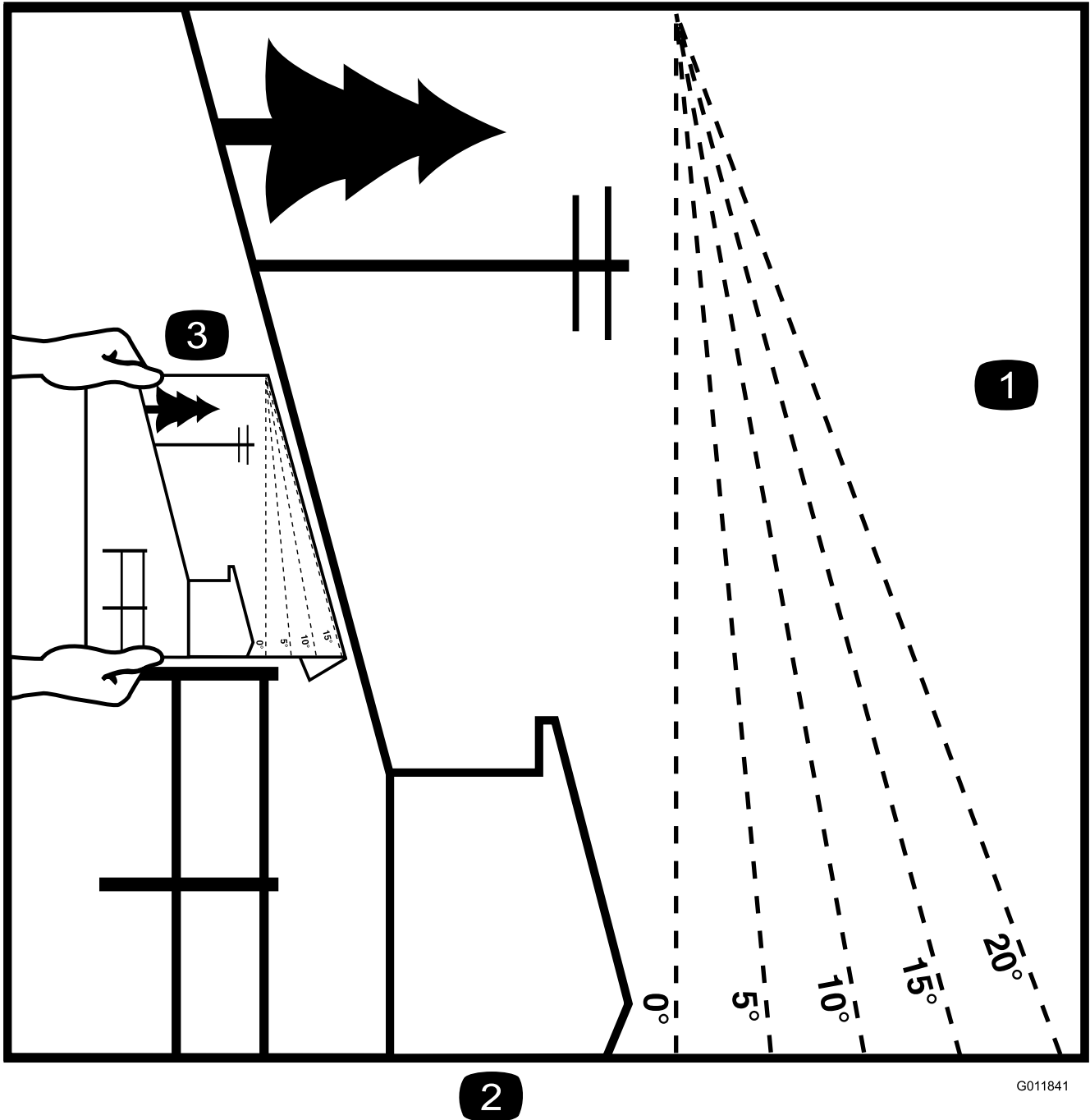

G011841

2

Figure 75

This page may be copied for personal use.

1. The maximum slope you can safely operate the machine on is **15 degrees**. Use the slope indicator to determine the degree of slope of hills before operating. **Do Not operate this machine on a slope greater than 15 degrees.** Fold along the appropriate line to match the recommended slope.
2. Align this edge with a vertical surface, a tree, building, fence pole, etc.
3. Example of how to compare slope with folded edge.

EXMARK ACCESSORIES AND OPTIONS*

MID-MOUNT RIDING ACCESSORIES AND OPTIONS

CUSTOM RIDE SEAT SUSPENSION SYSTEM	OPERATOR CONTROLLED DISCHARGE
FULL SUSPENSION SEAT	SUN SHADE
DECK LIFT ASSIST KIT	TRASH CONTAINER
HITCH KIT	TURF STRIPER
LIGHT KIT	ULTRA VAC COLLECTION SYSTEM
12V POWER PORT	ULTRA VAC QUICK DISPOSAL SYSTEM
MICRO-MULCH SYSTEM	

OUT-FRONT RIDING ACCESSORIES AND OPTIONS

CUSTOM RIDE SEAT SUSPENSION SYSTEM	SNOW BLADE
DUAL-TAIL WHEEL	SNOWBLOWER
FLOOR PAN EXTENDER	SUN SHADE
HITCH KIT	TRASH CONTAINER
LIGHT KIT	ULTRA VAC COLLECTION SYSTEM
MICRO-MULCH SYSTEM	ULTRA VAC QUICK DISPOSAL SYSTEM
ROLL OVER PROTECTION SYSTEM (ROPS)	WEATHER CAB

WALK-BEHIND ACCESSORIES AND OPTIONS

GRASS CATCHER	TURF STRIPER
MICRO-MULCH SYSTEM	STANDON

*Some accessories and options not available for some models.

Place Model No. and Serial No.
Label Here (Included in the Literature
Pack) or Fill in Below

Model No. _____

Serial No. _____

Date Purchased _____

Engine Model No. and Spec. No. _____

Engine Serial No. (E/No) _____

©2016 Exmark Mfg. Co., Inc.
Industrial Park Box 808
Beatrice, NE 68310
All Rights Reserved

Part No. 4502-907 Rev. B
(402) 223-6375
Fax (402) 223-5489
Printed in the USA



www.exmark.com