

Aqara

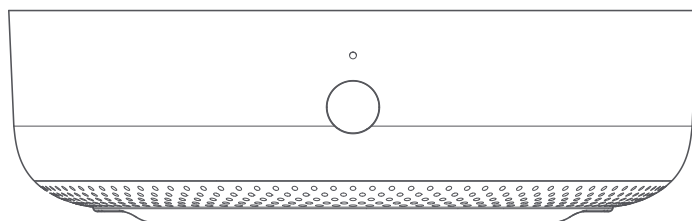

Hub M200 Online User Manual

Product Introduction

The Hub M200 is a smart home control hub by Aqara which supports multiple wireless protocols. It can connect Zigbee and Thread child devices, and can act as a Matter Controller and Thread Border Router. It can connect paired Zigbee child devices to third-party Matter ecosystems via a Matter bridge. It supports dual-band 2.4GHz and 5GHz Wi-Fi 6 wireless networking, and can easily discover and bind devices through Aqara MagicPair technology. It also supports Bluetooth pairing to connect Aqara Voice Mate. It can be powered by either USB Type-C or PoE charging.

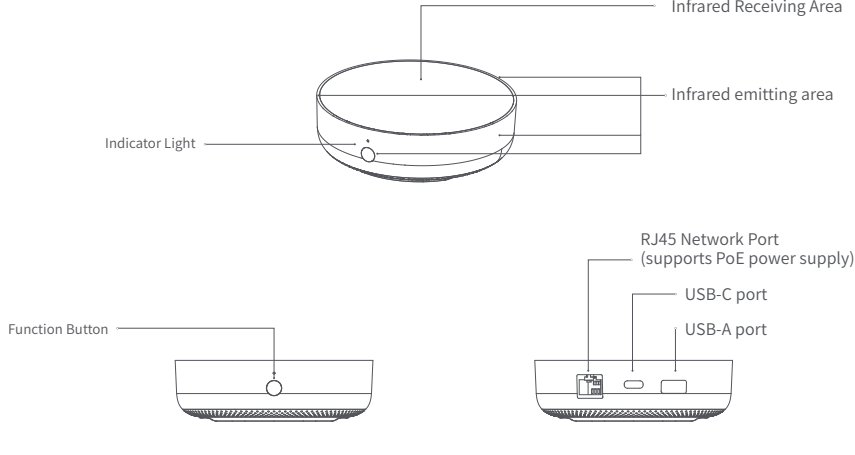

Device Connecting & Initialization

1. Download the Aqara APP

Search for "Aqara Home" in the Apple App Store, Google play, Xiaomi GetApps, Huawei App Gallery, or scan the following QR code to download the Aqara Home App.



2. Set up the hub

1 Choose the installation location of the hub: the hub should be 2-6 meters away from the router in the house, and avoid metal obstacles between the hub and router or around the hub.

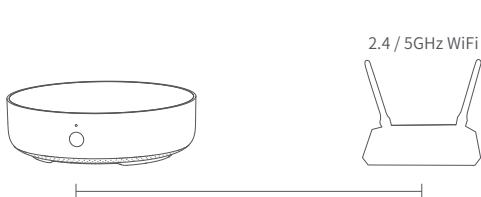

2 Select power supply port:

Type C: Please use a 5V=2A adapter (purchased separately) and a USB power cable to power the hub on.

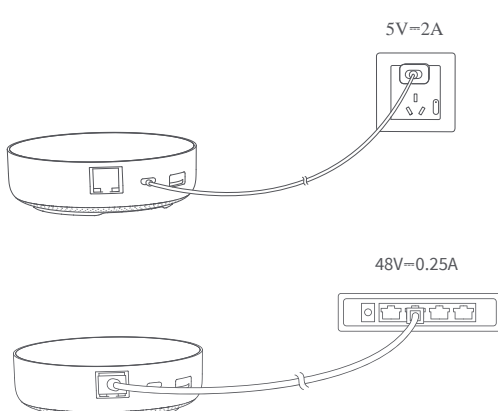

You can power the hub and connect it to your network using a PoE-enabled router or network switch with an RJ45 cable.

* When both Type C and RJ45 PoE power supply are connected, the device will prioritize power supply from the RJ45 PoE.

3 Wait for the yellow hub indicator light to change from solid to flashing.

4 Select the networking method:

Wireless connection: Connect your phone to a 2.4/5GHz Wi-Fi network. After powering on the hub, open the Aqara Home APP and follow the instructions to complete the network configuration.

Wired connection: Using a wired network connection can effectively avoid connection instability caused by unstable Wi-Fi. If possible, it is recommended to connect the hub via wired network. After powering on the hub, use an RJ45 cable to connect the hub's RJ45 port to a LAN port on your router. Enter the Aqara Home APP and follow the instructions to complete the network configuration.

3. Add the product to the Aqara Home app

Please open the Aqara Home app, tap "Home" and then tap "+" in the top right corner to enter the "Add Device (Accessory)" page, select "Hub M200", and add it according to the instructions in the Aqara Home app. After a successful connection, the status indicator light will be solid blue.

*This product supports the Aqara MagicPair technology and the device can be automatically discovered by the Aqara Home app when it is powered on and in pairing mode. Please select the device and follow the instructions in the app to complete the network configuration.

*Please place your phone as close to the hub as possible when pairing, and make sure that the phone and the hub are on the same Wi-Fi network.

Common reasons for binding failure:

- 1 After powering on, please press the function button for more than 10s until the yellow light flashes, then retry pairing in the app.
- 2 Check if your router has enabled Wi-Fi anti-leeching settings, preventing the device from connecting to the network properly.
- 3 Check if your router has enabled AP isolation, preventing your phone from discovering the device within the local network.
- 4 It is recommended not to connect to bridged networks.

Connecting to HomeKit

Open the Apple "Home" app, click "+" in the upper right corner to enter the Add Accessories page, scan or manually input the HomeKit setup code (HomeKit QR code) on the product side, and bind the device to HomeKit.

Here are some common troubleshooting steps for HomeKit addition failures:

- 1 Error Message: "Unable to add accessory". Repeated connection failures have caused error data in the iOS cache. Please restart the iOS device (iPhone or iPad) reset the hub and try again.
- 2 Error Message: "Accessory added". Please restart the iOS device and reset the hub, then manually enter the HomeKit setup code to add the hub.
- 3 Error Message: "Accessory not found". Please reset the hub, wait for 3 minutes, and add it again by manually entering the HomeKit setup code.

Connecting to a third-party Matter ecosystem

Please use the third-party Matter app to scan the Matter QR code on the User Manual or enter the 11-digit setup code to add the device. If the Matter QR code is missing, it can be found in the Aqara Home app - Device page - Expose to Matter.

*Note: Please keep the QR code on the product or in the user manual in a safe place.

4. Binding a child device

(1) Binding Zigbee and Bluetooth child devices

Please operate according to the child device's user manual, and select the Hub M200 to complete for binding.

(2) Bind Matter Over Thread device

This product serves as a Thread Border Router and supports connecting sub-devices using the Matter Over Thread protocol.

Please connect the device according to the device's user manual (Thread devices do not need to select to specify the Hub M200 during the binding process).

5. Other functions

For more device functions, please log in to the Aqara Home app and explore!

Button Operation Guide

| Button Press Action | Explanation |
|---|---|
| Press and hold for 10 seconds | Reset network |
| Quick press 10 times | Restore factory settings |
| Quick press 3 times | Enter pairing mode for Zigbee sub-device |
| Quick press 2 times | During Alarm (Home/Away/Sleep Mode): Cancels alarm & deactivates the current Guard Mode During Basic Guard Alarm (no mode Guard): Cancels alarm without turning off Guard Mode Guard Mode Active (No Alarm): Deactivates current Guard Mode (Home/Away/Sleep) |
| Press 1 time | Clears active alarms Exits sub-device pairing mode Stops voice announcements |
| Quick press 5 times and long press 3~5s | Network Standby Mode: Disables all wireless signals (Wi-Fi/Zigbee/Thread/BLE). The wired network & IR functions remain active. |

Description of Indicator Lights

| Indicator Light Status | Device Status |
|----------------------------|---|
| Solid yellow light | Starting up |
| Flashing yellow light | Waiting to connect |
| Flashing blue light | Network connecting |
| Slow flashing blue light | Connection successful and account connected |
| Solid blue light | Functioning normally |
| Solid white light | 10 mins without network configuration |
| Solid purple light | Network standby mode |
| Flashing purple light | Enables adding child devices |
| Slow flashing yellow light | Firmware upgrading |
| Off | Indicator light turned off/power off/sleep mode |

Product Specifications

Model: HM-G03E/HM-G03D

Power Input: 5V=2A

Dimensions: $\Phi 100.5 \times 30.75$ mm

PoE Input: 48V=0.25A

Wireless Protocols: Wi-Fi IEEE 802.11 a/b/g/n/ac/ax 2.4 GHz / 5 GHz, Zigbee/Thread IEEE 802.15.4, Bluetooth

Operating Temperature: -10°C ~ 50°C

Operating Humidity: 0 ~ 95% RH, non-condensing

Notice

Communication between iPhone, iPad, Apple Watch, HomePod, HomePod mini or Mac and the HomeKit enabled Hub M200 is secured by HomeKit technology.

Use of the "Works with Apple" badge means that an accessory has been designed to work specifically with the technology identified in the badge and has been certified by the developer to meet Apple performance standards. Apple is not responsible for the operation of this device or its compliance with safety and regulatory standards.

Apple, Apple Watch, HomeKit, HomePod, HomePod mini, Siri, iPad, iPad Air, and iPhone are trademarks of Apple Inc., registered in the U.S. and other countries.

Online Customer Service: www.aqara.com/support

Manufacturer: Lumi United Technology Co., Ltd.

Address: Room 801-804, Building 1, Chongwen Park, Nanshan iPark, No. 3370, Liuxian Avenue, Fuguang Community, Taoyuan Residential District, Nanshan District,

Shenzhen, China.

Email: support@aqara.com

Made in China