

**Gastronomy Plus Ltd**

THE HOME OF

**DELIVITA®**

---



**Origin. Wood  
Fired Pizza Oven  
User Manual**

---





# **Welcome to the Outsider Club**

**You didn't choose ordinary.  
You chose outside.**

# Welcome to your Delivita Wood Fired Oven

**A place where fire, food,  
and people come together,  
and life slows down just  
enough to matter.**

This is cooking back to simple.

Real flames. Real ingredients. Real moments.

## **Outside. Unplugged.**

No apps.

No notifications.

No distractions.

Just you, the people you love, and the unmistakable glow of the fire.

Because the best conversations don't happen on screens. They happen outside, catching up, laughing, sharing stories, and eating food that tastes better because it was made together.

## **Fire Your Way**

Powered by wood.

Driven by flavour.

Cooking with real fire means embracing tradition, control, and unmistakable taste.

With wood as your heat source, every pizza is shaped by flame, patience, and craft - exactly as it should be.

## **A Few Simple Ways to Get the Best From It**

Let the oven come fully up to temperature before cooking, great food loves patience.

Use the heat zones: hotter near the flame, gentler towards the mouth of the oven.

Turn, rotate, and trust your instincts, fire cooking is about feel as much as technique.

And don't worry if it doesn't all come together first time.

There may be a few pizza casualties along the way - we love to see a wonky pizza or a slightly singed crust. With a little patience and practice, you'll soon find your rhythm and become a master of the fire.

Because perfection isn't the goal.

Great food, shared outside, is.

## **Living Life to the Full**

From slow afternoons that drift into long evenings, to impromptu gatherings that turn into unforgettable nights - this is where memories are made.

Food prepared beautifully.

Moments shared effortlessly.

Life lived properly.

That's what we're all about.

Welcome to Delivita

Welcome outside.



## USE OUTDOORS ONLY

PLEASE READ INSTRUCTIONS CAREFULLY BEFORE USE

RETAIN THIS MANUAL FOR FUTURE REFERENCE

---

### **Hazardous fire may result if these instructions are ignored.**

It is the consumer's responsibility to see that the barbecue is properly assembled, installed, and taken care of. Failure to follow instructions in this manual could result in bodily injury and/or property damage.

---

### **Read the instructions before using the appliance.**

Retain this manual for future reference.

Use outdoors only.

Warning accessible parts may be very hot. Keep young children away.

Do not move the appliance during use.

Do not modify the appliance.

This appliance must be kept away from flammable materials during use.

The regulator and hose must be connected correctly to the appliance. A spanner must be used to tighten the nut onto the connection thread.

---

## ASSEMBLY

**WARNING:** Whilst every effort has been made in manufacture of your pizza oven to remove any sharp edge, you should handle all components with care to avoid accidental injury.

**ASSEMBLY:** The oven comes pre-assembled. Please read all instructions thoroughly before proceeding. Please refer to the parts list and assembly diagram as necessary.



# EXPLODED DIAGRAM

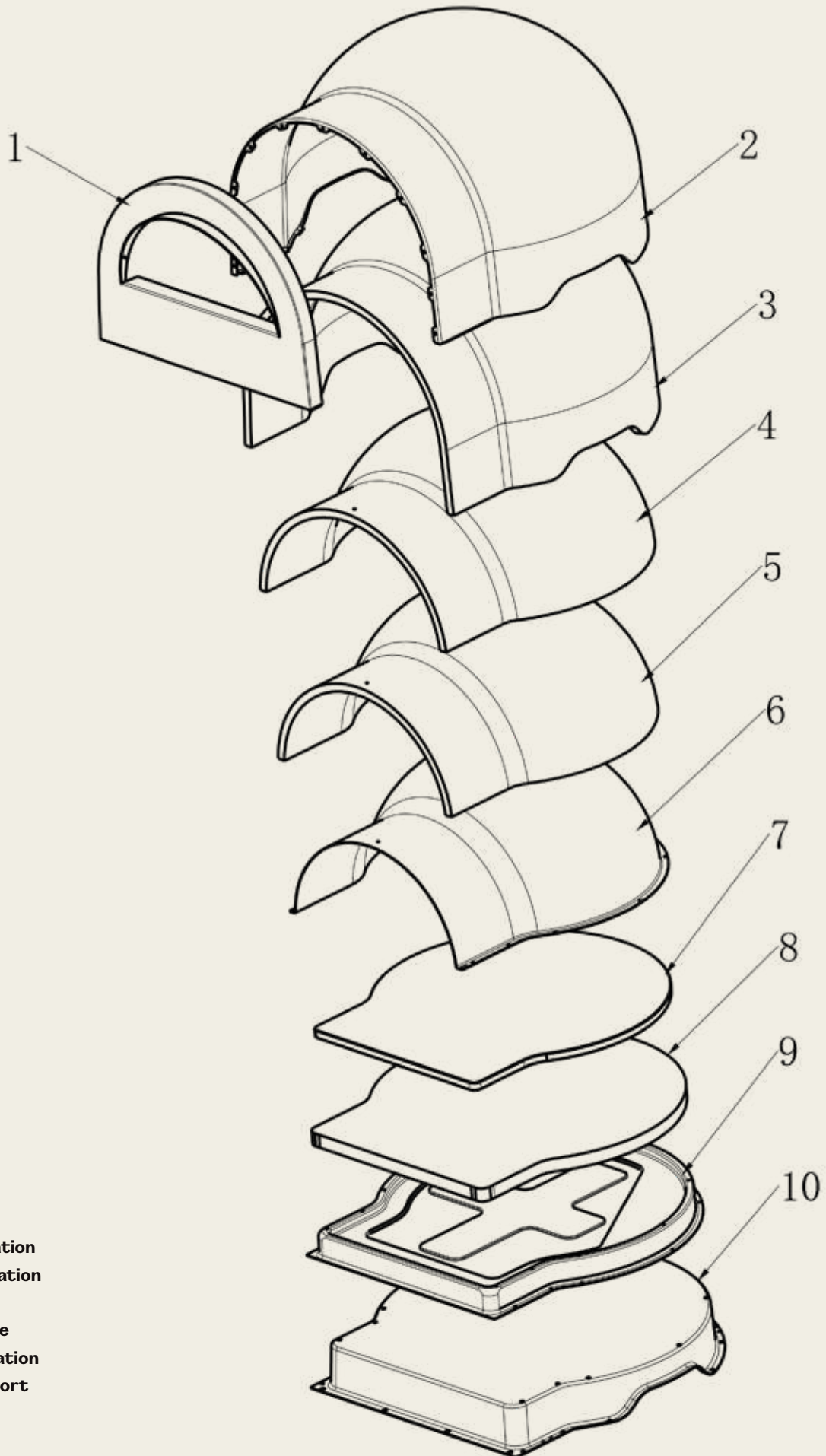

- 1 Frontage
- 2 Shell
- 3 Insulation
- 4 Clay Insulation
- 5 Inner Insulation
- 6 Inner
- 7 Pizza Stone
- 8 Base Insulation
- 9 Base Support
- 10 Base



## UNPACKING THE OVEN

Remove the packaging and use the side handles to lift the oven out of the box.

Place your oven onto a stable surface; it can be positioned on the Fold Away Oven Stand or a solid hard level surface (such as a wooden table). The Fold Away Oven Stand or table must be situated on a solid and even surface and must be able to hold the oven weight of around 50kg.

**WARNING:** there is a risk of toppling over if the oven is not placed on level ground or if sited on soft ground. Make sure the oven is at a safe distance from any flammable items or surfaces and that there is enough space around the entrance of the oven for smoke and fumes to disperse.

**WARNING:** the outer surfaces of this appliance can reach temperatures above 50°C (120°F). No flammable materials must be used within 1 meter of this appliance.

**WARNING:** The base of the oven can reach up to 60°C. Please position the oven on a non-flammable base.

---

## FITTING CLEARANCE

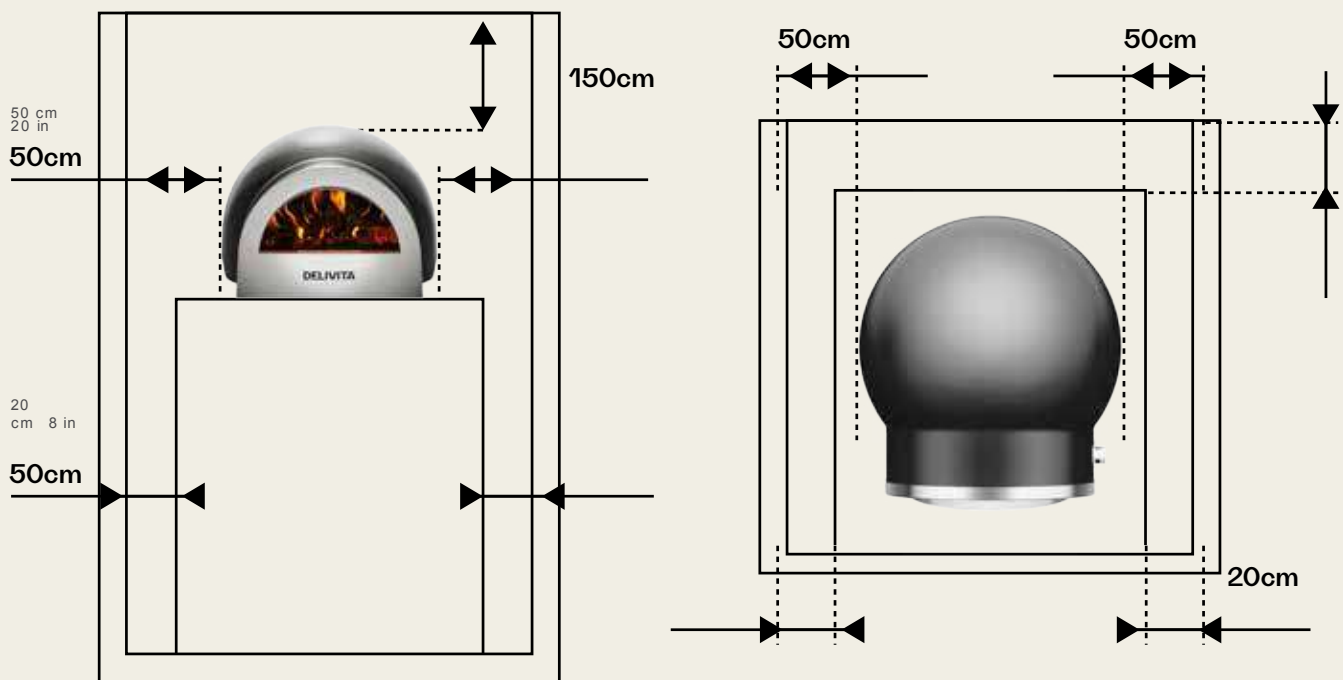

## USING WOOD

The Delivita wood-fired oven is designed for cooking with wood as the sole heat source, delivering a truly traditional and authentic wood-fired experience. Cooking exclusively with wood allows you to harness natural flame and radiant heat, producing high temperatures and rich, natural smoky flavours that define classic wood-fired pizza and live-fire cooking.

When cooking with wood only, it is acceptable to light and maintain the fire directly on the cooking stone. This method allows the oven to heat naturally and evenly, with heat gradually saturating the stone and oven chamber. Care should be taken not to overfill the oven with wood; instead, maintain a steady, controlled flame. This ensures efficient combustion, consistent temperatures, and optimal cooking performance throughout the cooking process.

---

## LIGHTING & COOKING WITH WOOD

1. Once you have cured the oven you'll be ready to start cooking.
2. Place an eco fire-lighter towards the front/middle of the oven. Create a Jenga-like tower around the fire-lighter: position two pieces of kindling lengthways and either side of the fire-lighter; place the third piece on top, and across the two pieces.
3. Light the eco fire-lighter and add a fourth piece of kindling on top of the existing kindling. Then add a small piece of hardwood around 3cm width on top of your tower.
4. After 10 minutes, the flame will have taken to the top log. Add another small hardwood log. Nudge the logs together so they overlap one on top of the other and leave for approx. 20 minutes. **TIP:** Always allow airflow. If the wood is directly on the base with no embers underneath, the flame will go out, creating a lot of smoke.
5. The fire should now have taken. At this point, push the fire to the back of the oven slowly, using the wire brush or the prodder, add further wood to maintain the fire but not exceeding two small logs at any one time.
6. Allow a further 7-10 minutes for the oven to reach its optimum temperature of 450°C to 550°C. Clean the cooking area using a metal wire brush and you're ready to go.

**TIP:** If the flame goes out and/or you have a lot of smoke coming out of the oven, ensure the log has an airflow, then tear some bits from your eco lighter, position on to the prodder and light. Place on top of the log in the back of the oven, this will light the log and stop the excess smoke. Our Prod & Blow accessory can also help you re-ignite the flame by gently blowing down the pipe handle with the base directed at the embers.

**NEVER inhale whilst using the Prod & Blow pipe as this could cause serious injury or burns.**

**TIP:** Monitor the level of fire during cooking: do not allow the wood to be consumed completely before adding further logs.

**PLEASE NOTE:** A fire built too close to the front of the oven can cause a permanent separation of the metal frontage.



Scan the QR Code  
to learn more about  
how to light your  
oven using wood.



## AFTER COOKING

Once cooking is complete, stop adding fuel and allow the wood fire to burn down naturally until the flames extinguish and only embers remain. Leave the oven in open air to aid cooling and ensure all heat has dissipated before handling or cleaning. Protective gloves (such as oven gloves) should be worn when handling any hot components.

---

## MATERIAL AND CURING INFORMATION

### Material:

Your Delivita oven is manufactured from heat-resistant fire clay combined with high-temperature-resistant sand.

### What Is Curing?

During manufacturing, water is used to form the clay. Before the oven can be used, this moisture must be slowly dried out. This process is known as curing and consists of two stages:

1. Drying – removing residual moisture from the clay
2. Tempering – gradually strengthening the clay through controlled heating

### Normal Effects During Curing

While curing, the following may occur and are completely normal:

- Small hairline cracks may appear on the surface of the clay
- A slight plastic-like smell may be noticeable
- Small amounts of water may seep from the sides during curing or the first few uses

These effects will not affect the performance or safety of the oven. However, warm water may stain wood or surrounding furniture, so please ensure nearby surfaces are protected during the curing process.

### When to Cure the Oven

- When it is new
- If it has become damp
- As a precaution if it has been stored unused for several months
- Do not leave the oven unattended during curing.

### Curing Time Guidelines

Approx. 4 hour cure time using a low, controlled wood fire.



## CLEANING & CARE

1. All cleaning and maintenance should be carried out when the pizza oven is cool.
2. Store the pizza oven out of direct sunlight and indoors where possible and when storing for extended periods of time. The pizza oven should not be exposed to harsh weather conditions such as snow, heavy rain or strong winds.
3. Wait for the pizza oven to cool completely before moving.

### Maintenance:

1. Keep appliance area clear and free from combustible materials, gasoline, and other flammable vapours and liquids;
2. Do not obstruct the flow of combustion and ventilation air;
3. Keep the ventilation opening(s) of the cylinder enclosure free and clear from debris;
4. Clean appliance, including special surfaces, with recommended cleaning agents, if necessary;
5. Check and clean the burner tubes for insects and insect nests. A clogged tube can lead to a fire beneath the appliance.

Your pizza oven will look better and last longer if you keep it clean.

### Care & Maintenance:

Apart from cleaning, your wood-fired pizza oven is a fairly low maintenance item. A couple of things are worth looking at though.

1. A rain cover is also recommended to cover your wood fired pizza oven and maintain and protect from all weather conditions.
2. We recommend cleaning and maintaining the pizza oven monthly.



# Our Award-Winning Origin Wood-Fired Pizza Oven

The Delivita Origin Wood Fired Pizza oven is the perfect fusion of modern technology and artisan craftsmanship

Meet the award-winning Delivita Origin Oven. Designed in Britain and made for sharing, it features traditional clay insulation used in wood fired ovens for centuries, alongside a high-temperature powder-coated steel shell and stainless-steel inner chamber. Reaching over 550°C in just 30 minutes and retaining heat for hours, it lets you cook without limit.



Delivita Origin Very Black



Delivita Origin Royal Blue



Delivita Origin British Racing Green



Delivita Origin Hale Grey



Delivita Origin Blaze Orange



Delivita Origin Chilli Red



Wood Fired



Ready to cook



Reaches temps



Delicious Pizza in





# Gastronomy Plus Ltd

THE HOME OF

# DELIVITA<sup>®</sup>

---

**Keep updated & share  
your Delivita journey**



@HelloDelivita



@HelloDelivita



@DelivitaLife

---

[www.Delivita.com](http://www.Delivita.com)

---

+44 (0)1524 770060

---

[hello@Delivita.com](mailto:hello@Delivita.com)