

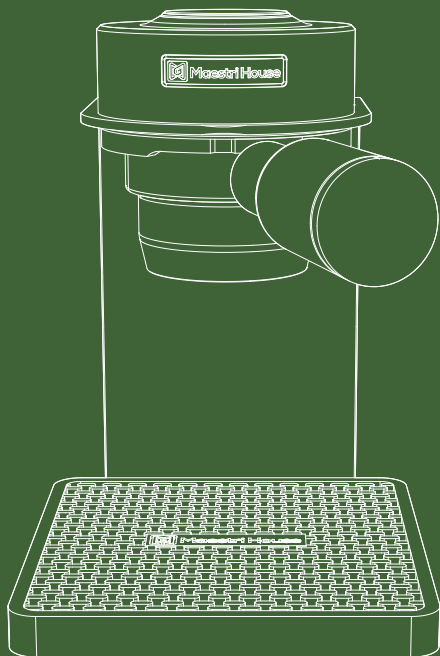

# Maespresso 58

## User's Manual



Model: MHMP58

# CONTENTS

<b>Before You Begin</b>	2
<b>Product Layout</b>	3
<b>Product Installation</b>	4
<b>Coffee Quality Assurance</b>	5
<b>Usage Instructions</b>	5
<b>Cleaning and Maintenance</b>	9
<b>Precautions</b>	10
<b>Troubleshooting</b>	10
<b>Disposal and Recycling</b>	11
<b>Customer Support</b>	11
<b>About Us</b>	11

## Before You Begin

### Dear Maespresso 58 Espresso Maker User:

Thank you for choosing our Maespresso 58 espresso maker. This is an innovative and convenient pneumatic espresso maker designed especially for espresso enthusiasts, offering you the finest espresso experience.

The core design of Maespresso 58 is to simplify the intricate steps of espresso extraction, allowing users to enjoy top-quality espresso with minimal effort, anytime and anywhere. It integrates the following features:

1. **Pneumatic Espresso Maker:** Our espresso maker uses air pump for extraction, ensuring each cup is brimming with rich flavor and a creamy texture. This simplifies the espresso-making process, allowing you to effortlessly brew espresso anytime and any where.
2. **Maximum Pressure of 11BAR:** A pressure level reaching up to 11BAR ensures full extraction of coffee grounds, presenting the perfect concentration and crema.
3. **Minimalist Design:** Our designers have seamlessly blended modern aesthetics with functionality, making the Maespresso 58 a sophisticated addition to your kitchen.
4. **Compact Size, Easy Storage:** The mini dimensions of the Maespresso 58 ensure it can find its spot in any corner without taking up too much space.
5. **No Preheating, No Plugging In:** Eliminate the wait time, and enjoy delicious espresso anytime—even during the busiest mornings.
6. **Portable:** Its lightweight design and portability allow you to brew your favorite espresso anytime, anywhere, without location constraints.
7. **Easy to Clean:** The Maespresso 58 features a simple structure that is easy to disassemble and clean, ensuring every cup of coffee is fresh and sanitary.

We hope that the Maespresso 58 not only brings you a delightful coffee experience but also becomes an integral part of your life, accompanying you through every cherished moment. This manual provides a detailed guide to ensure you can fully harness the potential of this espresso maker.

Please read this manual carefully, and always feel free to reach out to our support team. If you have any questions or need assistance, we are more than happy to help.

Thank you again for choosing the Maespresso 58 espresso maker. Here's to brewing cup after cup of delicious coffee!

**Best wishes,  
The Maestri House Team**

## Product Layout

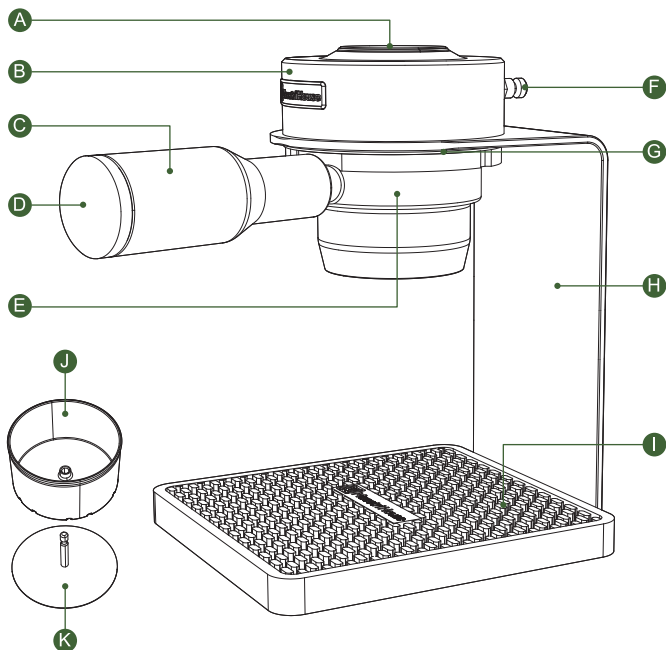

**A** Pressure Gauge

**C** Handle

**E** Basket

**G** Main Body Fixation Ring

**I** Drip Tray

**K** Puck Screen

**B** Main Body

**D** WDT Tool

**F** 8mm Quick Connect Nozzle

**H** Stand

**J** Silicone Thermal Sleeve

# Product Installation

## 1 Main Body Stand Installation

With the Main Body's LOGO facing forward, insert it into the stand from top to bottom. Use the provided black fixing ring to slide up from the bottom of the Main Body, fitting it into the Main Body's slot.

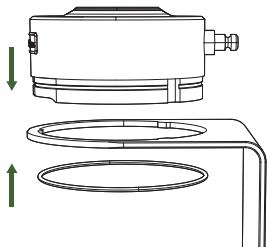

## 2 WDT tool and Handle

Hide the WDT tool inside the handle by clockwise screw. Turn counter-clockwise a half-turn to take out the WDT tool.

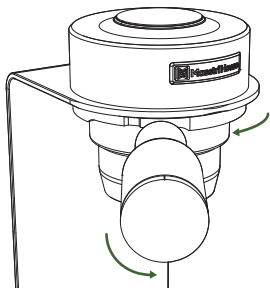

## 3 Drip Tray Usage and Installation

During WDT distribution, operations can be conducted above the drip tray to prevent coffee grounds from scattering on the countertop. After distribution, the drip tray can be placed in the slot beneath the stand, serving as an anti-slip pad for the cup.

## Product Installation

Purchase fresh coffee beans from local roasters.

Use filtered water.

Use a coffee scale to precisely measure the amount of coffee beans and the output of the espresso. Grind the coffee beans in advance before preparing the espresso. It's recommended to invest in a high-quality manual grinder.

Before tamping, use the WDT tool to stir and break up clumps for even distribution, which aids in uniform coffee extraction.

For optimal espresso extraction results, place a 53mm filter paper at the bottom of the basket. This reduces the fine grounds from passing through the filter or clogging the filter holes, affecting the coffee's taste.

The bottom of the basket is designed as an exposed bottomless filter, allowing for a clearer observation of the entire coffee extraction process. This design helps in identifying any blockages, dead spots, or uneven extractions.

## Usage Instructions

- 1 Pour the ground coffee into the basket. Then rotate the tail of the handle clockwise to remove the WDT tool and gently stir the coffee ground to break up any clumps, ensuring even distribution.

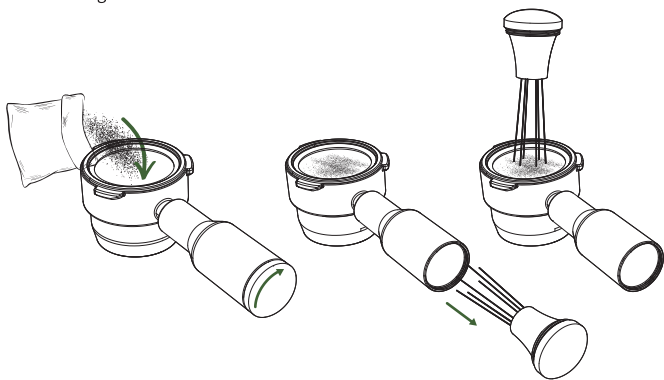

- 2 Use the tamper to compact the coffee powder into a solid puck. The integrity and density of the puck are crucial for the quality of the coffee extraction.

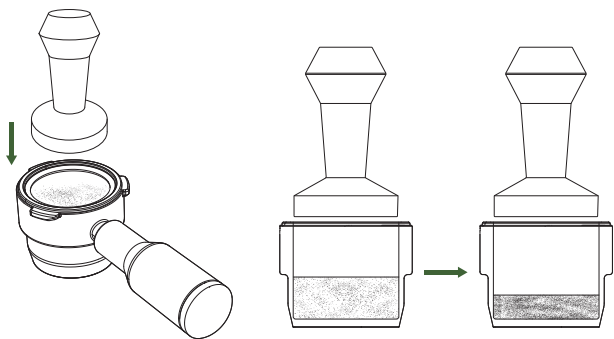

- 3 Once tamping is complete, place the silicone thermal puck screen. The screen ensures that the hot water doesn't disperse the coffee grounds, while the silicone sleeve minimizes contact between hot water and the stainless-steel surface to prevent temperature drop.

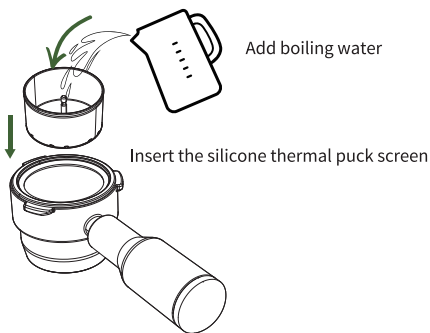

<b>Dosing Range:</b>	0.56~0.78 oz /16~22g
<b>Maximum Water Chamber Capacity:</b>	2.7oz/80ml
<b>Recommended Water Temperature:</b>	
<b>Dark roast beans:</b>	185°F to 194°F (85°C to 90°C)
<b>Medium roast beans:</b>	190°F to 198°F (88°C to 92°C)
<b>Light roast beans:</b>	198°F to 203°F (92°C to 95°C)

**4** Portafilter and Main Body Installation:

Lift the handle from the bottom left until it contacts the Main Body. Align the handle with the left side of the LOGO, and after fitting it into the slot, rotate the handle to the right side of the LOGO for a complete assembly.

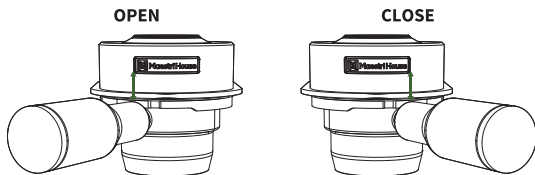

- 5** The 8mm quick-connect nozzle at the back of the main body is designed to connect to an electric air pump or gas cartridge. After connecting, it provides high-pressure gas to the main body. This high-pressure gas applies force to the hot water inside the basket. As the pressurized hot water passes through the coffee puck, it extracts the coffee, which then flows out from the bottom of the basket.

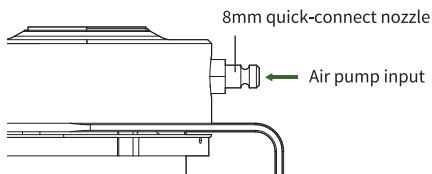

**Note:** To terminate extraction, press the pressure relief valve to release the high pressure inside the basket, immediately stopping the extraction.

- 6** When installing the gas cylinder, first turn the switch clockwise to the end, ensuring the output is completely closed.

**Pressure Gauge:** After installing the gas cylinder, the pressure typically rises to over 1000psi (depending on the pressure inside the cylinder). When the pressure drops to around 500psi, the output pressure will noticeably be insufficient, suggesting a need to replace the gas cylinder. The pressure gauge reading is affected by temperature. If the ambient temperature is low, the pressure will also decrease.

Use CO2 cartridges with 3/8-24 threads. To install, turn the cartridge clockwise until the pressure gauge needle moves, indicating the internal pressure of the cartridge. If you hear a hissing sound, it indicates an incomplete seal between the cartridge and the valve; continue to turn the cartridge clockwise until the sound disappears.

The 8mm quick connect is the output port, connecting to the input port on the back of the Main Body.

The function of the pressure relief valve is to release the pressure inside the basket after extraction.

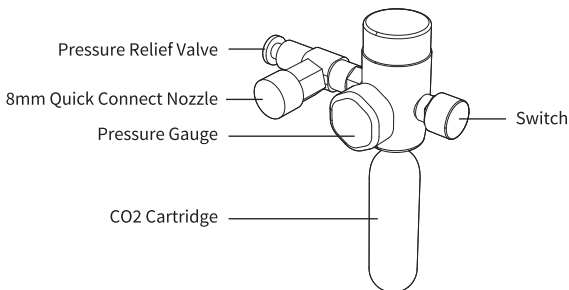

**7** How to disassemble and connect the air valve:

For the air valve (air pump), first pull the ring of the 8mm quick connector towards the rear, unlocking it. Align the 8mm female quick connector on the air valve (air pump) with the male connector, release the ring, and it will snap back into its original locked position. The air valve (air pump) is now correctly installed. To detach the air valve (air pump), similarly pull the ring of the 8mm female quick connector, unlocking it, allowing for the removal of the air valve (air pump).

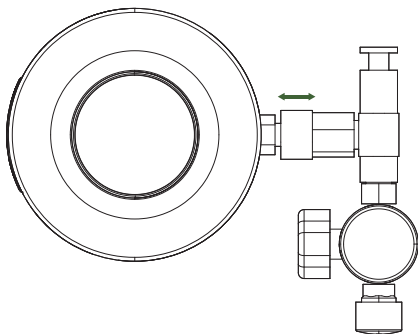

- 8** How to use the air valve to pressurize the Maespresso 58 espresso maker:  
Once the cartridge is installed and connected to the air valve, you can start pressurizing the Maespresso 58 espresso maker. The full name of the air valve is the 10BAR constant pressure throttle valve. Regardless of the pressure in the cartridge (must be higher than 10BAR), the 10BAR constant pressure throttle valve will reduce the output pressure to 10BAR. The function of the air valve switch is to adjust the flow rate of the output gas. Turning it clockwise will increase the output, while turning counterclockwise will decrease the output until fully closed.

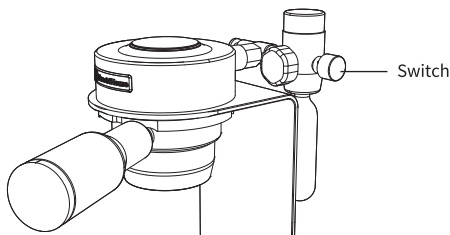

## Cleaning and Maintenance

Regular inspection and cleaning are crucial, and proper maintenance can ensure the longevity of your Maespresso 58 espresso maker. The design of the Maespresso 58 is simple, and only the basket directly contacts the coffee. Therefore, cleaning should be primarily focused on the basket. Since the Maespresso 58 basket uses a double mesh design, there might be coffee residue in between the two meshes. Here's how to clean it:

### 1. Basket:

(1) If cleaned shortly after use, rinse the bottom of the basket with hot water. The remaining coffee will naturally be washed away.

(2) If forgotten about and not cleaned immediately after use, dried coffee will form hard-to-clean stains. Place the basket in boiling water and heat it simultaneously for a few minutes. The boiling water can dissolve the dried coffee. If the cleaning result is still unsatisfactory, extend the boiling time to more than 10 minutes.

### 2. Main Body:

If there's moisture or coffee on the Main Body after use, wipe it dry with a cloth or paper towel and place it in a well-ventilated area to air dry. For the air intake (8mm quick connector nozzle), use an appropriate wrench to remove it, then take out the internal filter cotton. Continuous use or misuse (e.g., overfilling with water) can wet the filter cotton. It's recommended to dry or replace the filter cotton. Finally, let all components air dry for several hours before reassembling.

## Precautions

1. The maximum operating pressure should not exceed 11BAR. Exceeding this pressure might damage the equipment or even pose a risk.
2. After extraction, ensure that the pressure is fully released (pressure gauge reading at 0) before removing the handle and basket. Never forcibly remove the basket during extraction or if the pressure hasn't been fully released.
3. If using an electric pump as a pressurization tool, pay attention to the cleanliness of the pump and the surrounding environment.



Maximum Safe Pressure



Safely Remove the basket

## Troubleshooting

To achieve high-quality espresso, it's crucial to maintain an internal pressure between 8 to 11 bars. For this, the following parameters need to be controlled:

1. Coffee grinding amount. If there's too much ground coffee in the basket, it will increase the internal pressure.
2. Coarseness of the coffee grind. Overly fine ground coffee will elevate the internal pressure. If you consistently can't extract coffee or only obtain a negligible amount, you should slow down the pressing speed. Grind the coffee beans coarser and reduce the amount of ground coffee. If coffee extraction is too easy and lacks the presence of coffee oils, you need to grind the beans finer. The coffee grind amount can be increased to a maximum of 22 grams.

## Disposal and Recycling



Please dispose of the packaging according to local waste management regulations. When the product reaches the end of its lifecycle, it should not be discarded as household waste; instead, please take it to a specialized recycling facility. Thank you for contributing to environmental conservation.

## Customer Support

**Every product we offer is backed by a 12-month warranty policy.**

For any after-sales requirements, please email us at [support@maestrihouse.com](mailto:support@maestrihouse.com), and we will assist you wholeheartedly.

**We assume no responsibility for any incidental or consequential damages caused by misuse of the machine.**

Our warranty does not cover:

1. Damages caused by misuse, abuse, negligence, commercial use, or any other use not mentioned in this manual.
2. Replacement of seals, the Main Body, basket, coffee tamper, and powder needle.
3. Product damages due to natural causes, corrosion, or gradual deterioration.

Any unauthorized disassembly or repair will void the product warranty.

Any product repair or replacement, return shipping costs are borne by the customer.

## About Us

Maestri House is a brand that provides aesthetically pleasing, functional, and enjoyable coffee equipment and services for those who love making their own coffee. To learn more about our range of products and services, please visit our official website at

[www.maestrihouse.com](http://www.maestrihouse.com)