

iClever

# PRODUCT USER MANUAL

Model: BTH26  
Wireless Headphones



— Amazon's —

# Leading

Kids Headphones Brand

5

Million+:  
5 million+ products  
sold worldwide

50

Well-known Evaluation Media Reports:  
reported by many well-known  
media and KOL

118

Countries:  
available in 118  
countries

iClever is recommended by many authority media as the best kids headphones including **CNET, Tech Advisor, Android Police, CGM, Parents, The Bump** etc. Built with our patented Safe-Volume Technology, which protects children's hearing with volume limiter while providing crisp, clear sound. We're protected millions of children from hearing damage while helping millions of parents rest easy knowing their children are safe.

## The fifth generation of Safe Volume Technology innovation and upgrade

Safe material

Professional acoustic adjustment

Craftsmanship spirit, detail by detail

1

2

3

4

- The first generation 85dB: refers to a single frequency point
- The second generation 85dBA (Laeq/pink noise): The spectral intensity of the entire sound, and then superimposed the A-weighting correction curve, the average value obtained
- The third generation of cochlear resonance pre-attenuation: the sound that is likely to cause hearing impairment (2kHz-4kHz sound waves) is attenuated by 5-10 decibels, effectively protecting high-frequency hearing loss while taking into account the clarity of the earphones
- The fourth generation circuit control: 85dBA volume control can be realized for any equipment
- The fifth generation decibel meter: the sound decibel level is displayed on the screen

iclever has acoustic engineers serving first-line audio brands to ensure that each product meets its acoustic standards



**CPC**



foldable



colorful lighting



stretchable



sturdy material



cat ear series stickers

## Wireless Headphones



BTH12



BTH18



BTH22



BTH27

## Wired Headphones



IC-HS19



IC-HS26



IC-HS22

## Classroom Headphones



IC-HS21



IC-HS14



IC-HS27



IC-HS28

## Cat Ear Headphones



Meow Macaron



Meow Cookie



Meow Donut



Meow Lollipop

## Noise Cancelling Headphones



BTH20



BTH26

## Safety Earmuffs



IC-EM01



FOCUS

## Open-Ear Headphones



OWS01

The above products belong to iClever brand series products

# Package Contents



1 x 3.5mm Audio Cable



1 x Type-C Charging Cable



1x Cloth Pouch



1 x User Manual



# Product Diagram

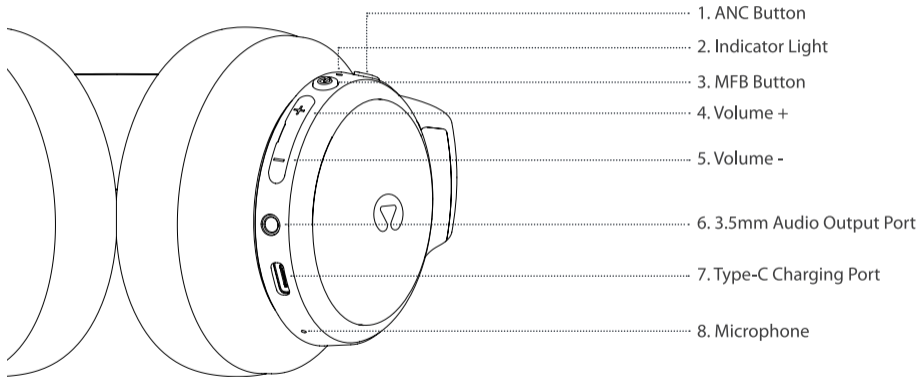

**DE:**

- 1.ANC-Taste
- 2.Anzeigelampe
- 3.Multifunktionstaste
- 4.Lautstärke +
- 5.Lautstärke -
- 6.3,5-mm-Audioausgangsanschluss
- 7.Type-C-Anschluss
- 8.Mikrofon

**FR:**

- 1.Bouton ANC
- 2.Voyant lumineux
- 3.Bouton multifonction
- 4.Volume +
- 5.Volume -
- 6.Port de sortie audio 3,5 mm
- 7.Port de type C
- 8.Microphone

**ES:**

1. Botón ANC
2. Luz indicadora
3. Botón multifunción
4. Volumen +
5. Volumen -
6. Puerto de salida de audio de 3,5 mm
7. Puerto tipo C
8. Micrófono

**IT:**

- 1.Pulsante ANC
- 2.Indicatore luminoso
- 3.Pulsante multifunzione
- 4.Volume +
- 5.Volume -
- 6.Porta di uscita audio da 3,5 mm
- 7.Porta di tipo C
- 8.Microfono

**CN:**

- 1.ANC 按键
2. 指示灯
3. 多功能按键
4. 音量“+”键
5. 音量“-”键
- 6.3.5mm 音频输出端口
- 7.Type-C 接口
8. 麦克风

# Power On/Off

1. Power On: In the power-off state, press and hold the MFB button for 2 seconds to power on the headphones. The headphones will play the voice prompt "Power On," and the indicator light will flash red and blue alternatively, indicating that the headphones have entered pairing mode.
2. Power Off: In the power-on state, press and hold the MFB button for 5 seconds to power off the headphones. The headphones will play the voice prompt "Power Off," and all lights will turn off, indicating that the headphones are powered off.

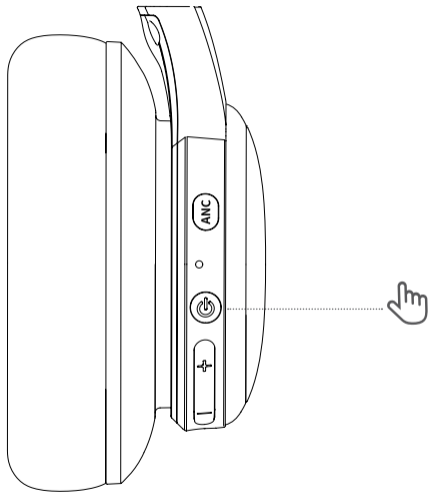

## DE:

### 1. Einschalten :

Halten Sie im ausgeschalteten Zustand die MFB-Taste 2 Sekunden lang gedrückt, um den Kopfhörer einzuschalten. Es folgt die Sprachansage "Power On" des Kopfhörers. Die abwechselnd blau und rot blinkende Anzeigeleuchte zeigt an, dass der Kopfhörer in den Kopplungs-Modus übergegangen ist.

### 2. Ausschalten :

Drücken Sie im eingeschalteten Zustand die MFB-Taste und halten Sie sie 5 Sekunden lang gedrückt, um den Kopfhörer auszuschalten. Es folgt die Sprachansage "Power Off" des Kopfhörers. Alle Leuchten erlöschen und zeigen damit an, dass der Kopfhörer ausgeschaltet ist.

## FR:

### 1. Mise en marche :

Lorsque l'appareil est éteint, appuyez sur le bouton multifonction et maintenez-le enfoncé pendant 2 secondes. Vous entendrez

le message vocal "Power On", et le voyant lumineux clignotera alternativement en rouge et en bleu, indiquant le mode d'appairage.

### 2. Arrêt :

En état de fonctionnement, appuyez sur le bouton multifonction et maintenez-le enfoncé pendant 5 secondes. Vous entendrez le message vocal "Power Off" et tous les voyants s'éteindront, indiquant l'arrêt de l'appareil.

## ES:

### 1. Encendido:

Estando apagado, presione y mantenga el botón multifunción durante 2 segundos. Escuchará el mensaje de voz "Power On" y la luz indicadora parpadeará en rojo y azul alternativamente, indicando el modo de emparejamiento.

### 2. Apagado:

Estando encendido, presione y mantenga el botón multifunción durante 5 segundos. Escuchará el mensaje de voz "Power Off" y todas las luces se apagarán, lo que indica que está apagado.

## IT:

### 1. Accensione:

Nello stato di spegnimento, tenere premuto il pulsante multifunzione per 2 secondi. Sentirai il messaggio vocale "Power On" e l'indicatore luminoso lampeggerà di rosso e blu alternativamente, indicando la modalità di abbinamento.

### 2. Spegnimento:

Nello stato di accensione, tenere premuto il pulsante multifunzione per 5 secondi. Sentirai il messaggio vocale "Power Off" e tutte le luci saranno spente, indicando lo spegnimento.

## CN:

### 1. 开机:

关机状态下, 长按 2 秒 多功能键开机, 耳机语音播放 "Power On", 指示灯红蓝交替闪烁, 耳机进入配对模式。

### 2. 关机:

开机状态下, 长按 5 秒 多功能键关机, 耳机语音播放 "Power Off", 全部灯灭, 耳机关机。

# Bluetooth Pairing

1. When first turning on the device, its indicator light turns blue for 1 second, then the Bluetooth enters the pairing state, and the red and blue lights flash alternately.
2. Open the Bluetooth on your phone and select "iClever BTH26" in the device list for Bluetooth pairing.

## Note:

1. After the second power-on, the phone will automatically reconnect to the last paired Bluetooth device. If the last paired Bluetooth device is out of range, the headphones will enter pairing mode.
2. If the device exceeds the effective Bluetooth range of the headphones, it will automatically disconnect.
3. If the headphones fail to connect via Bluetooth for more than 5 minutes, it will shut down automatically.

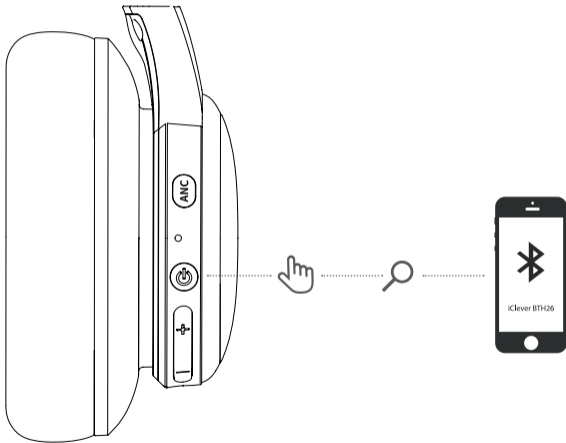

**DE:**

1. Beim ersten Einschalten des Geräts leuchtet die Kontrollleuchte 1 Sekunde lang blau, dann wechselt Bluetooth in den Kopplungsstatus und die roten und blauen Lichter blinken abwechselnd.
2. Öffnen Sie die Bluetooth-Funktion auf Ihrem Handy und wählen Sie „iClever BTH26“ in der Geräteliste für die Bluetooth-Kopplung aus.

**Hinweis:**

1. Nach dem zweiten Einschalten verbindet sich das Telefon automatisch wieder mit dem zuletzt gekoppelten Bluetooth-Gerät. Wenn sich das zuletzt gekoppelte Bluetooth-Gerät außerhalb der Reichweite befindet, wechselt der Kopfhörer in den Kopplungsmodus.
2. Überschreitet das Gerät die effektive Bluetooth-Reichweite des Kopfhörers, wird die Verbindung automatisch getrennt.
3. Kann der Kopfhörer länger als 5 Minuten keine Bluetooth-Verbindung herstellen, schaltet er sich automatisch ab.

**FR:**

1. Lors de la première mise sous tension de l'appareil, son voyant devient bleu pendant 1 seconde, puis le Bluetooth entre en état d'appairage et les voyants rouge et bleu clignotent alternativement.
2. Ouvrez le Bluetooth sur votre téléphone et

sélectionnez "iClever BTH26" dans la liste des appareils pour l'appairage Bluetooth.

**Remarque :**

1. Après le deuxième allumage, le téléphone se reconnecte automatiquement au dernier appareil Bluetooth apparié. Si le dernier appareil Bluetooth apparié est hors de portée, les écouteurs passeront en mode d'appairage.
2. Si l'appareil dépasse la portée Bluetooth effective des écouteurs, il se déconnecte automatiquement.
3. Si les écouteurs ne parviennent pas à se connecter via Bluetooth pendant plus de 5 minutes, ils s'éteindront automatiquement.

**ES:**

1. Cuando los auriculares estén encendidos, deslice el interruptor a la posición ON. Las luces de colores se encenderán, indicando el modo de emparejamiento Bluetooth. La luz indicadora parpadeará en rojo y azul alternativamente.
2. Abra el Bluetooth en su teléfono y seleccione "iClever BTH26" en la lista de dispositivos para el emparejamiento Bluetooth.

**Nota:**

1. Tras el segundo encendido, el teléfono se volverá a conectar automáticamente al último dispositivo Bluetooth emparejado. Si el último dispositivo Bluetooth emparejado está fuera del alcance, los

- auriculares entrarán en modo de emparejamiento.
2. Si el dispositivo excede el alcance efectivo de Bluetooth de los auriculares, se desconectará automáticamente.
3. Si los auriculares no se conectan mediante Bluetooth durante más de 5 minutos, se apagarán automáticamente.

**IT:**

1. Quando si accende il dispositivo per la prima volta, la spia diventa blu per 1 secondo, quindi il Bluetooth entra nello stato di accoppiamento e le luci rossa e blu lampeggiano alternativamente.
2. Apri il Bluetooth sul tuo telefono e seleziona "iClever BTH26" nell'elenco dei dispositivi per l'accoppiamento Bluetooth.

**Nota:**

1. Dopo la seconda accensione, il telefono si riconnetterà automaticamente all'ultimo dispositivo Bluetooth abbinato. Se l'ultimo dispositivo Bluetooth abbinato è fuori portata, le cuffie entreranno in modalità di abbinamento.
2. Se il dispositivo supera la portata Bluetooth effettiva delle cuffie, si disconnetterà automaticamente.
3. Se le cuffie non riescono a connettersi tramite Bluetooth per più di 5 minuti, si spegneranno automaticamente.

**CN:**

1. 在首次开机状态下，蓝色指示灯常亮 1 秒，蓝牙进入配对状态，红蓝灯交替闪烁。

2. 打开手机蓝牙，在设备列表中，查找并选择“iClever BTH26”蓝牙配对名称进行蓝牙配对连接，语音播放“Connected”。

**备注:**

1. 第二次开机之后，手机会默认回连上次最后连接的蓝牙设备；若上次最后连接的蓝牙设备不在蓝牙有效范围，耳机回连失败后，会自动进入配对状态。

2. 设备超出耳机有效蓝牙距离，会自动断连。

3. 耳机超过 5 分钟未蓝牙连接成功，会进入自动关机状态。

## Wired Connection

Insert the provided 3.5mm audio cable, with one end into the 3.5mm audio interface of the headphones and the other end into a device that supports a 3.5mm interface, such as a tablet, computer, laptop, or smartphone.

**DE:**

Stecken Sie das mitgelieferte 3,5-mm-Audiokabel mit dem einen Ende in die 3,5-mm-Audioschnittstelle des Kopfhörers und mit dem anderen Ende in ein Gerät, das eine 3,5-mm-Schnittstelle unterstützt, z. B. ein Tablet, Computer, Laptop oder ein Smartphone.

**FR:**

Insérez le câble audio de 3,5 mm fourni, avec une extrémité dans l'interface audio de 3,5 mm du casque et l'autre extrémité dans un appareil compatible avec une interface de 3,5 mm, tel qu'une tablette, un ordinateur, un ordinateur portable ou un smartphone.

**ES:**

Inserte el cable de audio de 3,5 mm proporcionado, con un extremo en la interfaz de audio de 3,5 mm de los auriculares y el otro en un dispositivo que admita una interfaz de 3,5 mm, como una tablet, ordenador, portátil o teléfono inteligente.

**IT:**

Inserire il cavo audio da 3,5 mm fornito, con un'estremità nell'interfaccia audio da 3,5 mm delle cuffie e l'altra estremità in un dispositivo che supporta un'interfaccia da 3,5 mm, come un tablet, un computer, un laptop o uno smartphone.

**CN:**

取出附赠的 3.5mm 音频线，一端接口插入耳机的 3.5mm 音频接口，一端接口插入支持 3.5mm 接口的平板，电脑，笔记本，手机等音频播放设备。

## Noise Reduction

When powering on the headphones, its noise reduction is off by default. Short press the "ANC" button to enter Noise Cancellation

mode. Short press the "ANC" button again to turn off Noise Cancellation.

**Note:** Noise reduction is not supported when using a wired connection.

**DE:**

Beim Einschalten des Kopfhörers ist die Geräuschreduzierung standardmäßig ausgeschaltet. Drücken Sie kurz die „ANC“-Taste, um den Geräuschunterdrückungsmodus zu aktivieren. Drücken Sie die „ANC“-Taste erneut, um die Geräuschunterdrückung zu deaktivieren.

Hinweis: Die Geräuschreduzierung wird nicht bei einer Kabelverbindung unterstützt.

**FR:**

Lorsque le casque est allumé, la réduction du bruit est désactivée par défaut. Appuyez brièvement sur le bouton "ANC" pour activer le mode Réduction de Bruit. Appuyez de nouveau brièvement sur le bouton "ANC" pour désactiver la Réduction de Bruit.

Remarque : la réduction du bruit n'est pas prise en charge lors de l'utilisation d'une connexion câblée.

**ES:**

Quando encienda los auriculares, la reducción de ruido estará desactivada por defecto. Presione brevemente el botón "ANC" para activar el modo de cancelación de ruido. Vuelva a presionar brevemente el botón "ANC" para desactivar la cancelación de

ruido.

Nota: La reducción de ruido no es compatible cuando se utiliza una conexión por cable.

#### **IT:**

Quando si accendono le cuffie, la sua riduzione del rumore è disattivata per impostazione predefinita. Premi brevemente il pulsante "ANC" per attivare la modalità di Cancellazione del Rumore. Premi di nuovo brevemente il pulsante "ANC" per disattivare la Cancellazione del Rumore.

Nota: la riduzione del rumore non è supportata quando si utilizza una connessione cablata.

#### **CN:**

耳机开机默认为降噪关闭状态，短按“ANC”降噪按键，进入”降噪“模式，再次短按“ANC”降噪按键，进入降噪关闭模式；

备注：耳机使用有线连接时，不支持降噪功能。

## **Button Functions**

#### **Volume Up :**

Press the "+" button

#### **Volume Down :**

Press the "-" button

#### **Next Track :**

Press and hold the volume + button for 2s

#### **Previous Track :**

Press and hold the volume - button for 2s

#### **Play/Pause :**

Press the MFB button

#### **Answer/End Call :**

Press the MFB button

#### **Reject Call :**

Press and hold the MFB button for 2s

#### **Clear Pairing List:**

When the headphones are powered on (connected) or in the pairing state, press and hold the Volume + Button & Volume - Button for 5 seconds. The headphones will automatically clear the pairing list and enter pairing mode, with the indicator light flashing red and blue alternately.

#### **DE:**

#### **Lautstärke erhöhen:**

Drücken Sie die Taste "+".

#### **Lautstärke verringern:**

Drücken Sie die Taste "-".

#### **Nächster Titel:**

Drücken und halten Sie die Taste "+" für 2 Sekunden

#### **Vorheriger Titel:**

Halten Sie die "-"-Taste 2 Sekunden lang gedrückt.

#### **Wiedergabe/Pause:**

Drücken Sie die Multifunktionstaste

#### **Anruf annehmen/beenden:**

Drücken Sie die Multifunktionstaste

#### **Anruf abweisen:**

Drücken und halten Sie die Multifunktionstaste für 2 Sekunden

#### **Kopplungsliste löschen:**

Wenn der Kopfhörer eingeschaltet (verbunden) ist oder sich im Kopplungs-Status befindet, halten Sie Lautstärke + Taste und Lautstärke - Taste 5 Sekunden lang gedrückt. Der Kopfhörer löscht automatisch die Kopplungsliste und wechselt in den Kopplungs-Modus, wobei die Anzeigeleuchte abwechselnd rot und blau blinkt.

#### **FR:**

#### **Augmentation du volume :**

Appuyez sur le bouton "+".

#### **Diminution du volume :**

Appuyez sur le bouton "-".

#### **Piste suivante :**

Appuyez sur le bouton "+" et maintenez-le enfoncé pendant 2 secondes

#### **Piste précédente :**

Appuyez sur le bouton "-" et maintenez-le enfoncé pendant 2 secondes

#### **Lecture/Pause :**

Appuyez sur le bouton multifonction

#### **Répondre/terminer l'appel :**

Appuyez sur le bouton multifonction

### **Rejeter l'appel :**

Appuyez sur le bouton multifonction et maintenez-le enfoncé pendant 2 secondes

### **Effacer la liste d'appairage :**

Lorsque le casque est sous tension (connecté) ou en mode d'appairage, appuyez sur Bouton Volume+ et Bouton Volume- et maintenez-les enfoncés pendant 5 secondes. Le casque efface automatiquement la liste d'appairage et passe en mode d'appairage, le voyant lumineux clignotant alternativement en rouge et en bleu.

### **ES:**

#### **Subir volumen:**

Presione el botón "+"

#### **Bajar volumen:**

Presione el botón "-"

#### **Pista siguiente:**

Mantenga presionado el botón "+" durante 2 segundos

#### **Pista anterior:**

Mantenga presionado el botón "-" durante 2 segundos

#### **Reproducir/Pausar:**

Presione el botón multifunción

#### **Responder/finalizar llamada:**

Presione el botón multifunción

#### **Rechazar llamada:**

Mantenga presionado el botón multifunción

durante 2 segundos

### **Borrar lista de emparejamiento:**

Cuando los auriculares estén encendidos (conectados) o en estado de emparejamiento, mantenga presionado el botón de volumen+ y botón de volumen- durante 5 segundos. Los auriculares borrarán automáticamente la lista de emparejamiento y entrarán en el modo de emparejamiento, con la luz indicadora parpadeando en rojo y azul alternativamente.

### **IT:**

#### **Volume su:**

premere il pulsante "+"

#### **Volume giù:**

premi il pulsante "-"

#### **Traccia successiva:**

tieni premuto il pulsante "+" per 2 secondi

#### **Traccia precedente:**

tieni premuto il pulsante "-" per 2 secondi

#### **Riproduzione/Pausa:**

premi il pulsante multifunzione

#### **Risposta/Fine chiamata:**

premi il pulsante multifunzione

#### **Rifiuta chiamata:**

tieni premuto il pulsante multifunzione per 2 secondi

#### **Cancella l'elenco di accoppiamento:**

quando le cuffie sono accese (collegate) o nello

stato di accoppiamento, tenere premuto il Pulsante Volume+ e Pulsante Volume- per 5 secondi. Le cuffie cancelleranno automaticamente l'elenco di abbinamento e entreranno in modalità di abbinamento, con la spia lampeggiante rossa e blu alternativamente.

### **CN:**

音量加: 短按 "+" 按键

音量减: 短按 "-" 按键

下一曲: 长按 "+" 按键 2 秒

上一曲: 长按 "-" 按键 2 秒

播放 / 暂停: 短按多功能按键

接听 / 挂断电话: 短按多功能按键

拒接来电: 长按多功能按键 2 秒

清除配对列表: 在开机状态 (已连接) 或配对状态下, 音量+ 键 & 音量- 键 5 秒, 耳机自动清除配对列表并进入配对模式, 耳机灯光红蓝交替闪烁。

## **Voice Prompt**

**Power on:** Power On

**Power off:** Power Off

**Pairing:** Pairing Mode

**Successful Bluetooth Connection:** Connected

**Bluetooth Disconnection:** Disconnected

**Low Battery Reminder:** Low Battery

**ANC On:** Noise Cancellation On

**ANC Off:** Noise Cancellation Off

**DE:**

**Einschalten:** Power On

**Ausschalten:** Power Off

**Koppeln:** Pairing Mode

**Erfolgreiche Bluetooth-Verbindung:**  
Connected

**Bluetooth-Verbindungstrennung:**  
Disconnected

**Erinnerung an niedrigen Batteriestand:** Low  
Battery

**Geräuschunterdrückung Ein:** Noise  
Cancellation On

**Geräuschunterdrückung Aus:** Noise  
Cancellation Off

**FR:**

**Mise sous tension :** Power On

**Arrêt :** Power Off

**Appairage :** Pairing Mode

**Connexion Bluetooth réussie :** Connected

**Déconnexion Bluetooth :** Disconnected

**Rappel de batterie faible :** Low Battery

**Réduction de Bruit Activée :** Noise Cancellation  
On

**Réduction de Bruit Désactivée :** Noise  
Cancellation Off

**ES:**

**Encendido:** Power On

**Apagado:** Power Off

**Emparejamiento:** Pairing Mode

**Conexión Bluetooth exitosa:** Connected

**Desconexión de Bluetooth:** Disconnected

**Recordatorio de batería baja:** Low Battery

**Cancelación de Ruido Activada:** Noise  
Cancellation On

**Cancelación de Ruido Desactivada:** Noise  
Cancellation Off

**IT:**

**Accensione:** Power On

**Spegnimento:** Power Off

**Abbinamento:** Pairing Mode

**Connessione Bluetooth riuscita:** Connected

**Disconnessione Bluetooth:** Disconnected

**Promemoria batteria scarica:** Low Battery

**Cancellazione del Rumore Attivata:** Noise  
Cancellation On

**Cancellazione del Rumore Disattivata:** Noise  
Cancellation Off

**CN:**

开机 : Power On

关机 : Power Off

配对 : Pairing Mode

蓝牙连接成功 : Connected

蓝牙断连 : Disconnected

低电量提醒 : Low Battery

开降噪 : Noise Cancellation On

关降噪 : Noise Cancellation Off

## Product Specifications

**Frequency Range:** 2.402G-2.48G Hz

**Maximum Transmission Power:** 4 dBm

**Battery Type:** Li-ion Battery

**Battery Parameters:** 3.7 Vdc 500mAh

**Charging Parameters:** DC 5V 1A

**DE:**

**Frequenzbereich:** 2.402G-2.48G Hz

**Maximale Sendeleistung:** 4 dBm

**Akku-Typ:** Li-Ionen-Akku

**Akku-Parameter:** 3.7 Vdc 500mAh

**Auflade-Parameter:** DC 5V 1A

**FR:**

Gamme de fréquence : 2.402G-2.48G Hz  
Puissance de transmission maximale : 4 dBm  
Type de batterie : Batterie Li-ion  
Paramètres de la batterie : 3.7 Vdc 500mAh  
Paramètres de charge : DC 5V 1A

**ES:**

Rango de frecuencia: 2.402G-2.48G Hz  
Potencia máxima de transmisión: 4 dBm  
Tipo de batería: Batería de iones de litio  
Parámetros de la batería: 3.7 Vdc 500 mAh  
Parámetros de carga: DC 5 V 1 A.

**IT:**

Gamma di frequenza: 2.402G-2.48G Hz  
Potenza Massima Di Trasmissione: 4 dBm  
Tipo di batteria: Batteria agli ioni di litio  
Parametri della batteria: 3.7 Vdc 500mAh  
Parametri di ricarica: DC 5V 1A

**CN:**

频率范围: 2.402G-2.48G Hz  
最大传输功率: 4 dBm  
电池类型: 锂离子电池  
电池参数: 3.7Vdc 500mAh

充电参数: DC 5V 1A

## How to Charge the Headphone

Connect the Type-C cable to the Type-C port on the headphone, and a 5V power outlet (power adapter is not included). The indicator light will glow red to indicate charging. When the headphone is fully charged, the red indicator light goes off.

**DE:**

Schließen Sie das Typ-C-Kabel an den Typ-C-Anschluss des Kopfhörers und eine 5-V-Steckdose an (Netzadapter ist nicht im Lieferumfang enthalten). Die Anzeigeleuchte leuchtet rot, um den Ladevorgang anzuzeigen. Wenn der Kopfhörer vollständig aufgeladen ist, die rote Kontrollleuchte erlischt.

**FR:**

Connectez une extrémité du câble de charge Type-C à un adaptateur d'alimentation 5V (non inclus), et l'autre extrémité au casque. Le casque s'éteint automatiquement pendant la charge et le voyant lumineux s'éteint. Pendant la charge, le voyant lumineux sera rouge fixe, et après la charge

complète, le voyant rouge s'éteint.

**ES:**

Conecte un extremo del cable de carga tipo C a un adaptador de corriente de 5 V (no incluido) y el otro extremo a los auriculares. Los auriculares se apagarán automáticamente durante la carga y la luz indicadora se apagará. Durante la carga, la luz indicadora permanecerá en rojo fijo y, tras la carga completa, el indicador rojo se apaga.

**IT:**

Collegare un'estremità del cavo di ricarica Type-C a un alimentatore da 5 V (non incluso) e l'altra estremità alle cuffie. Le cuffie si spegneranno automaticamente durante la ricarica e l'indicatore luminoso sarà spento. Durante la ricarica, l'indicatore luminoso sarà rosso fisso e, dopo essere stato completamente caricato, la spia rossa si spegne.

**CN:**

将 Type-C 充电线一端接入 5V 电源适配器 (产品不含适配器), 另一端接入耳机。充电状态下红灯常亮, 充满电后红灯熄灭。

## Warnings

1. Stop using the product if it is damaged.
2. Replace the USB interface of the charging

**cable, if it becomes hot.**

### **3.Keep away the product from high temperatures and open flames.**

#### **DE:**

1. Benutzen Sie das Produkt nicht mehr, wenn es beschädigt ist.
2. Tauschen Sie die USB-Schnittstelle des Ladekabels aus, wenn sie heiß wird.
3. Halten Sie das Produkt von hohen Temperaturen und offenen Flammen fern.

#### **FR:**

1. Cessez d'utiliser le produit s'il est endommagé.
2. Remplacez l'interface USB du câble de chargement si elle devient chaude.
3. Gardez le produit à l'écart des températures élevées et des flammes libres.

#### **ES:**

1. Deje de usar el producto si está dañado.
2. Reemplace la interfaz USB del cable de carga si se calienta.
3. Mantenga el producto alejado de altas temperaturas y llamas abiertas.

#### **IT:**

1. Smettere di usare il prodotto se è danneggiato.

2. Sostituire l'interfaccia USB del cavo di ricarica se si surriscalda.
3. Tenere il prodotto lontano da temperature elevate e fiamme libere.

#### **CN:**

1. 若产品损坏, 请停止使用。
2. 当充电线 USB 接口发热, 请及时更换。
3. 远离高温和火源。

#### **PL:**

1. Przestań używać produktu, jeśli jest uszkodzony.
2. Wymień interfejs USB kabla ładującego, jeśli się nagrzeje.
3. Trzymaj produkt z dala od wysokich temperatur i otwartego ognia.

#### **SV:**

1. Sluta använda produkten om den är skadad.
2. Byt ut USB-gränssnittet på laddningskabeln om den blir varm.
3. Håll produkten borta från höga temperaturer och öppen låga.

#### **NL:**

1. Stop met het gebruik van het product als het beschadigd is.
2. Vervang de USB-interface van de oplaadkabel als

deze heet wordt.

- 3.Houd het product uit de buurt van hoge temperaturen en open vuur.

#### **TP:**

1. Hasar görmüşse ürünü kullanmayı bırakın.
2. Şarj kablosunun USB arabirimi ısınırsa değiştirin.
3. Ürünü yüksek sıcaklıklardan ve açık alevden uzak tutun.

**EN:** Power consumption in off mode: 0.0350W

**DE:** Stromverbrauch im Aus-Zustand: 0.0350W

**FR:** Consommation électrique en mode arrêt: 0.0350W

**ES:** Consumo de energía en modo apagado: 0.0350W

**IT:** Consumo energetico in modalità off: 0.0350W

# Statements of Compliance

Product Model: BTH26

Name and Address of manufacture:

Thousandshores Deutschland GmbH, Sorbenstraße 22,  
20537 Hamburg, DE

Name and Address of Authorised Representative: APEX CE  
SPECIALISTS LIMITED, 89 Princess Street,  
Manchester, M14HT, UK

The statement of compliance is prepared by or on behalf  
of the manufacturer of the product.

In the opinion of the manufacturer, they have complied  
with either—(i) the applicable security requirements in  
Schedule 1 of SI 2023 No. 1007

Provision 5.1-1 of ETSI EN 303 645 & provision 5.1-2 of ETSI  
EN 303 645;

Provision 5.2-1 of ETSI EN 303 645;

Provision 5.3-13 of ETSI EN 303 645.

The defined support period for the product:  
20250101

signature, name and function of the signatory:

The place and date of issue:

Ding He, CEO  
Shenzhen, China 28-02-2024

## EN

The power delivered by the charger must be between min 0.06 Watts required by the radio equipment, and max 1.87 Watts in order to achieve the maximum charging speed.

## DE

Die vom Ladegerät gelieferte Leistung muss zwischen mindestens 0.06 Watt und maximal 1.87 Watt liegen, um die maximale Ladegeschwindigkeit zu erreichen.

## FR

La puissance délivrée par le chargeur doit être comprise entre le minimum de 0.06 watts requis par l'équipement radio et le maximum de 1.87 watts afin d'atteindre la vitesse de charge maximale.

## ES

La potencia entregada por el cargador debe estar entre un mínimo de 0.06 Watts requerido por el equipo de radio y un máximo de 1.87 Watts para lograr la máxima velocidad de carga.

## IT

La potenza erogata dal caricabatterie deve essere compresa tra minimo 0.06 Watt richiesti dall'apparecchiatura radio e massimo 1.87 Watt per raggiungere la massima velocità di ricarica.

充电器提供的功率必须是无线电所需的最小 0.06 瓦之间设备, 最大 1.87 瓦, 以实现最大充电速度。

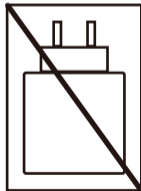
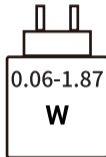

## FCC Statement

Changes or modifications not expressly approved by the party responsible for compliance could void the user's authority to operate the equipment. This equipment has been tested and found to comply with the limits for a Class B digital device, pursuant to Part 15 of the FCC Rules. These limits are designed to provide reasonable protection against harmful interference in a residential installation. This equipment generates uses and can radiate radio frequency energy and, if not installed and used in accordance with the instructions, may cause harmful interference to radio communications. However, there is no guarantee that interference will not occur in a particular installation. If this equipment does cause harmful interference to radio or television reception, which can be determined by turning the equipment off and on, the user is encouraged to try to correct the interference by one or more of the following measures:

- Reorient or relocate the receiving antenna.
- Increase the separation between the equipment and receiver.
- Connect the equipment into an outlet on a circuit different from that to which the receiver is connected.
- Consult the dealer or an experienced radio/TV technician for help.

This device complies with part 15 of the FCC rules. Operation is subject to the following two conditions

(1) This device may not cause harmful interference.  
(2) This device must accept any interference received, including interference that may cause undesired operation.

The device has been evaluated to meet general RF exposure requirement. The device can be used in portable exposure condition without restriction.

## IC Caution

This device contains licence-exempt transmitter(s)/receiver(s) that comply with Innovation, Science and Economic Development Canada's licence-exempt RSS(s). Operation is subject to the following two conditions : Operation is subject to the following two conditions: (1) This device may not cause interference, and (2) This device must accept any interference, including interference that may cause undesired operation of the device. Le présent appareil est conforme aux CNR d'Industrie Canada applicables aux appareils radio exempts de licence. L'exploitation est autorisée aux deux conditions suivantes: (1) l'appareil ne doit pas produire de brouillage, et (2) l'utilisateur de l'appareil doit accepter tout

brouillage radioélectrique subi, même si le brouillage est susceptible d'en compromettre le fonctionnement.

## DOC

### EN

Hereby, Thousandshores Deutschland GmbH declares that the radio equipment type Wireless Headphones BTH26 is in compliance with Directive 2014/53/EU.

The full text of the EU declaration conformity is available at the following internet address: <http://files.iClever.com/BTH26-eu-doc.pdf>

### DE

Hiermit erklärt Thousandshores Deutschland GmbH, dass der Funkanlagentyp Wireless Headphones BTH26 der Richtlinie 2014/53/EU entspricht.

Der vollständige Text der EU-Konformitätserklärung ist unter der folgenden Internetadresse verfügbar. <http://files.iClever.com/BTH26-de-doc.pdf>

### UK

Learn more about the UK Declaration of Conformity, Please click below link to download. <http://files.iClever.com/BTH26-uk-doc.pdf>

 [support@iclever.com](mailto:support@iclever.com)



Instagram  
@icleverkids



YouTube  
@iCleverKids



Facebook  
@icleverkids



Foldable



Maximum Noise Cancelling  
depth:36dB (ANC+PNC)



Wireless Built-in  
Microphone



Safe  
Material