

User manual

● *Blueair*



SCAN FOR SUPPORT

Humidifier H35i

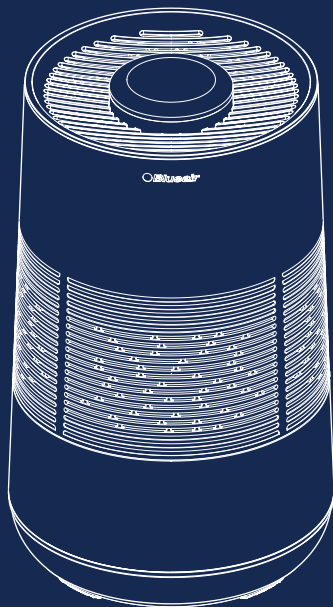

Table of Contents

Table of Contents

Safety Information	3
Regulatory Information	5
Product Map	6
Control Panel	7
Control and Display	8
Connect to the Blueair app	10
How to Use Tips	11
Maintenance Information	12
Troubleshooting	14

Read and save these instructions.

Blueair Humidifier is an electrical appliance for indoor use only. Take the necessary precautions to reduce the risk of fire, electric shock, or injury.

WARNING: RISK OF ELECTRIC SHOCK – These servicing instructions are for use by qualified personnel only. To reduce the risk of electric shock, do not perform any servicing other than that contained in the operating instructions unless you are qualified to do so.

- This appliance is not intended for use by persons (including children) with reduced physical, sensory or mental capabilities, or lack of experience and knowledge, unless they have been given supervision or instruction concerning use of the appliance by a person responsible for their safety.

Safety Information

Product name	Model number
Blueair Humidifier	3531911000

- To reduce the risk of fire, electric shock, or injury, only use manufacturer-recommended replacement parts.
- Supervise children to ensure that they do not play with the appliance.
- Cleaning and user maintenance shall not be done by children without supervision.
- Always disconnect the appliance from the power supply before maintenance.
- If your Blueair appliance is found to be defective, we will replace it with the same or a similar model at no cost, per the warranty terms. Please use caution attempting repairs yourself, as this presents the danger of electrical shock or injury.
- Ensure the power cord and plug are not at risk of getting damaged. To avoid hazard, damaged power cords or plugs must be replaced by the manufacturer.
- If the appliance is damaged or malfunctions, turn it off, disconnect it from the power supply and contact Blueair.
- The power plug must be firmly inserted in the power outlet.
- Overfilling or cleaning the product without unplugging it may cause electric shock.
- Do not run the cord under carpeting, furniture, or appliances, or cover it with rugs. Keep the cord away from traffic areas to prevent tripping.
- Do not use dishwasher except for dishwasher safe* water tank. (*Based on life test of 50-90 minute cycles at min. 158°F (70°C) , using leading detergent)

- To reduce the risk of electric shock, this equipment has a polarized plug (one blade is wider than the other). This plug fits in a polarized outlet only one way. If it doesn't fit, reverse the plug. If it still doesn't fit, contact qualified personnel to install the proper outlet. Do not alter the plug.
- When unplugging the unit, pull on the adapter, not the power cord.
- Use the provided adapter to plug the humidifier directly and firmly into an appropriate electrical outlet. If the plug does not fit, do not alter the adapter in any way. Contact qualified personnel to install the correct outlet.
- Do not use an extension cord with this appliance.
- Do not use the included adapter for anything else but the appliance.
- Do not allow objects to enter or block the evaporative outlet as this can cause electric shock or damage the appliance.
- Do not place any objects on top of or directly against the appliance.
- Do not sit on, stand, climb onto, or hang from the appliance.
- Keep the appliance, including the adapter, at a safe distance from heated surfaces and open fire.
- When plugged in, keep the appliance away from standing water such as bathtubs and ensure the area around the appliance is dry before plugging in the appliance.
- Keep the appliance and adapter away from chemicals such as pesticides and deodorants.
- Place the humidifier on the floor or a stable surface to prevent tipping.
- Do not use the appliance outdoors.
- Always turn off and unplug the appliance before moving it, refilling water, cleaning, or performing maintenance.
- Never clean with gasoline, chemical solvents, or corrosive materials as these agents may damage the humidifier.
- Only fill the water tank with clean water, do not use any other liquids.

WARNING: Skin or eye damage may result from directly viewing the light produced by the UV lamp located inside the pump of this apparatus.

Regulatory Information

WARNING: Changes or modifications to this unit not expressly approved by the party responsible for compliance could void the user's authority to operate the equipment.

NOTE: This equipment has been tested and found to comply with the limits for a Class B digital device, pursuant to Part 15 of the FCC Rules. These limits are designed to provide reasonable protection against harmful interference in a residential installation. This equipment generates, uses and can radiate radio frequency energy and, if not installed and used in accordance with the instructions, may cause harmful interference to radio communications.

However, there is no guarantee that interference will not occur in a particular installation. If this equipment does cause harmful interference to radio or television reception, which can be determined by turning the equipment off and on, the user is encouraged to try to correct the interference by one or more of the following measures:

- Reorient or relocate the receiving antenna.
- Increase the separation between the equipment and receiver.
- Connect the equipment into an outlet on a circuit different from that to which the receiver is connected.
- Consult the dealer or an experienced radio/TV technician for help.

This device complies with Part 15 of the FCC Rules. Operation is subject to the following two conditions:

- This device may not cause harmful interference.
- This device must accept any interference received, including interference that may cause undesired operation.

This Class B digital apparatus complies with Canadian ICES-003.

This device contains licence-exempt transmitter(s)/receiver(s) that comply with Innovation, Science and Economic Development Canada's licence-exempt RSS(s). Operation is subject to the following two conditions: (1) This device may not cause interference, and (2) This device must accept any interference, including interference that may cause undesired operation of the device.

FCC/ISED RF Exposure Information: This equipment should be installed and operated with a minimum distance of 20 centimeters between the radiator and your body.

Product Map

- A** User Interface
- B** Evaporative Outlet / Water Tank Fill Inlet
- C** Upper Body
- D** Wick Filter
- E** Reusable Filter Frame
- F** Replaceable Wick Filter
- G** Reusable Filter Cage Base
- H** Three Pin Connector
- I** Water Pump Module
- J** Water Pump Sponge Filter
- K** Water Tank

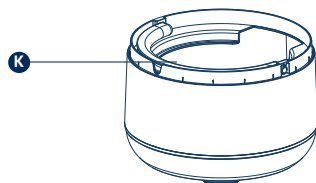
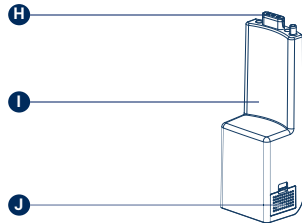
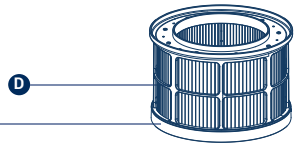
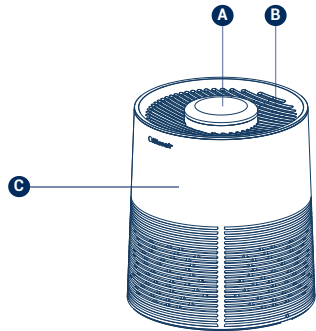
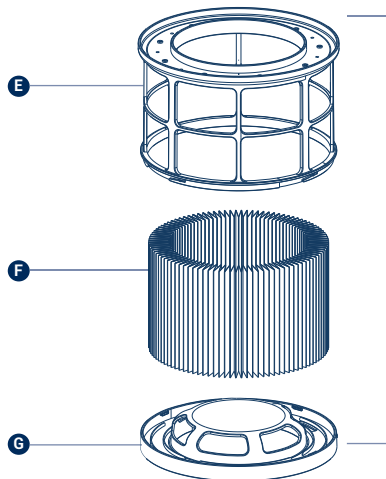

Control Panel



Control and Display



Turn On/Standby Button

Press to turn the humidifier on/standby.



Auto Dry Mode Indicator

Turns on when Auto Dry Mode is running. Auto Dry mode keeps using the fan to keep air circulating to dry out the filter wick in order to avoid dampness. Auto Dry mode cycle is 2 hours.

Note: When turned on, Auto Dry Mode will activate for 2 hours. There is a 5-minute delay before Auto Dry Mode is activated. You can exit Auto Dry Mode or disable this feature in the app if desired. For best hygiene and user experience we recommended leaving this feature activated.



Wi-Fi Indicator

To enable Wi-Fi pairing long press the "Auto Mode button" for 5 seconds.



Low Water Indicator

Lights up when the water in the tank is low. See refilling instructions (p.13).

Lights up when the humidifier top is removed.

When the water level is low, the Fan Speed, Auto and Night Mode buttons will blink when tapped as a reminder to refill the water.



Filter Reset Indicator

Turns on when the filter wick needs to be replaced.

Reminder! After replacing with a new filter wick you will need to reset its status on the device.

Press fan button for 15 second and the filter icon will blink and turn off.



Humidity Percentage

Shows real-time humidity level readings.



Auto Mode

Tap Auto Mode to enter function. When set on Auto Mode, your humidifier will automatically adjust humidification power to meet your target humidity level.

Set your target humidity level by tapping the Auto Mode button multiple times to choose between 30%, 40%, 50%, 60%, 70% or 80%. (Default is set to 50%).

You can also set Auto Mode or your target humidity level on the Blueair app.



Fan Speed

Tap to choose your humidification rate:



Low



Medium



High



Display Lock

Turns on when Display Lock is activated. Locks all buttons on the interface. To activate/deactivate long press for 5 seconds.

Interface will blink when any other button is tapped to indicate that Display Lock is on.



Night Mode

Tap to turn Night Mode on.

Night Mode turns humidifier to a custom fan speed with the quietest operation and dims the display to a low light level. You can also turn off the display completely in the Blueair app.

Connect to the Blueair app

Connecting to the Blueair app allows you to control the humidifier remotely and monitor humidity levels. The app offers enhanced functions and features.

Step 1

Download the Blueair app from the App Store or Google Play.

Step 2

Open the app. Create or sign into your Blueair account.

Step 3

Click on **Connect Product** and select **Humidifier**. Follow the instructions to complete app pairing.

First time connection tips

Make sure to turn on your humidifier. Once the Wi-Fi indicator is blinking, it is ready to be paired with your app.



Bluetooth is required for first time pairing. Turn your phone's Bluetooth on and keep your phone within 3ft of the humidifier for initial pairing.



Keep your humidifier within 15 feet of your Wi-Fi router to maintain optimal connection.



Make sure you are using a visible Wi-Fi network that is not hidden. VPN (Virtual Private Network) should be deactivated while using the Blueair App.



This humidifier can only connect to 2.4 GHz Wi-Fi. If you are using a dual-band Wi-Fi router, make sure to select 2.4GHz.



How to Use Tips

Adjust Interface Brightness

Press the Fan Speed button and On/Standby button simultaneously.

Keep holding the On/Standby button and tap the Fan Speed button to adjust brightness. If the brightness is at the lowest level, it will increase by one level. If it's at the highest level, it will decrease by one level.

You can also adjust the brightness using the Blueair app.

Enable/Disable Wi-Fi Pairing

If you choose not to connect the product, you can disable Wi-Fi by long pressing the Auto Mode button for about 15 seconds and then releasing it.

To reconnect your humidifier to Wi-Fi, hold the Auto Mode button for about 5 seconds until the Wi-Fi LED starts blinking. Then follow the instructions in the "Connect to the Blueair App" section.

Step 1



Step 2



5/15 seconds

Enable/Disable Display Lock

Long press Display Lock button for about 5 seconds (until all the LEDs of the interface light up and blink once). Then release.



5 seconds

When Display lock is enabled, the air purifier will continue to operate but all lights will flash twice when any button is pressed.

The device can be put into standby by pressing the On/Standby button twice when Display lock is enabled.

To unlock, hold down button again for about 5 seconds until the lights flash and buttons are functional again.

Filter Reset

Extra long press the Fan Speed Button for about 15 seconds until LEDs on the interface light up, then release.



15 seconds

Reminder! After replacing the wick filter, it is required to reset the status on the device. If done correctly, the wick filter replacement indicator will blink three times and then disappear.

Factory Reset

Extra long press On/Standby button for about 15 seconds (until all the LEDs of the interface light up and blink four times). Then release.



15 seconds

After factory reset, the humidifier restarts with default configuration will go into Standby mode.

Maintenance Information

Important! Turn the humidifier off and disconnect from the power supply before maintenance.

Changing your wick filter



When your humidifier's indicator light turns red, it's time to change the wick filter.

Step 1

Turn off and unplug. Lift the upper body away from the base.

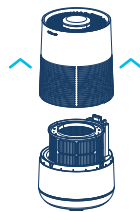

Step 2

Remove the wick filter assembly that rests on top of the pump and water tank.

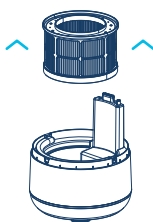

Step 3

Remove the wick filter from its assembly by twisting the base clockwise. Dispose of the old wick and replace it with a new one. Then reassemble.

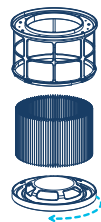

Step 4

Place the wick assembly back into the base, aligning it with the orientation arrows for proper installation.

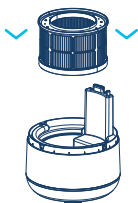

Step 5

Place the upper body back onto the base, aligning the dots on the front of the top and bottom halves. Plug in.

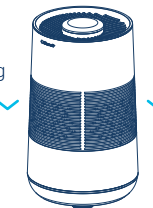

Step 6

Important! To reset the filter indicator, turn the device back on and long press the Fan Speed button for about 15 seconds until the LEDs light up. Then release.



Pump Sponge Filter Replacement:

To replace, unlatch door on pump and remove sponge filter. Discard and replace at same time as main wick filter. Included with replacement part #111687.

Filling and Refilling

Your Blueair humidifier is safe to use with clean water of your choice, including tap. It is recommended that the water tank be cleaned weekly to ensure proper operation. When your device detects low water, a red **Low Water Indicator** will appear on the display.

Option 1: Top Pour

- Turn off the device. Carefully pour water directly into the **top grill**, avoiding the waterproof display.
- Turn on the device. The Low Water Indicator will turn off automatically once water is sensed.
- The device will resume its previous mode.

Note: If water is added while the device is on please note there may be some water splash and draining sound if the fan is on; this is normal and will subside once refill is complete. **We recommend turning the device off.**

Cleaning Instructions:

To ensure optimal performance, clean your device weekly. Always disconnect the device from power prior.

- **Water Tank:** Clean the water tank using a mild detergent. Water tank is dishwasher safe* but do not put any other parts in the dishwasher. Wipe the water tank dry before reassembling. (*Based on life test of 50-90 minute cycles at min. 158°F (70°C) , using leading detergent)
- **Wick filter assembly:** Soak with mild or acid cleanser. 20g citric acid for every 1L of water for 1 hour. Rinse well under running tap water.
- **Water Pump:** Disassemble the device and remove the pump. Soak the pump with mild or acidic cleanser. 20g of citric acid for every 1L of water for 30 minutes. Rinse well under running tap water. Rinse sponge inside the pump with water.
- **Upper Body:** Wipe the body with a soft, dry or damp cloth to remove dust. Do not submerge in water.

Disposal and Recycling

This humidifier should be recycled as electronic waste. If you have any questions regarding the disposal of this humidifier, please contact your local waste management for best way to recycle.

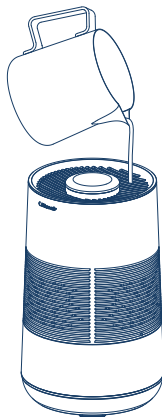

Option 2: Bucket Fill

- Turn off & lift up the top, wick and pump to refill the water tank. Refill the water tank to max fill line.
- Reassemble the device and turn on.
- Once water is automatically detected, the Low Water Indicator will turn off, and the device will resume at fan speed 1.

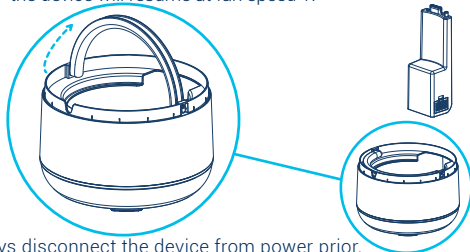

Troubleshooting

Issue	Potential Cause	Try this
There is no visible mist.	This humidifier uses evaporative technology which is mist-free and more hygienic.	
The humidifier has stopped running.	<p>The humidifier has run out of water in the tank.</p> <p>The humidifier is in Auto Mode and the target humidity level has been reached.</p> <p>The 3-pin connector between the pump and top are misaligned or unconnected.</p>	<p>Check if the "Low Water" icon is turned on and add more water to the tank.</p> <p>Check interface or app to see if target humidity has been reached. If it has it will go in standby.</p> <p>Remove top and make sure to align the dot on the top with the dot located on the water tank above max fill line.</p>
The humidity level isn't changing.	Your unit is set to Auto Mode and the target humidity level has been reached.	Increase target humidity level or exit Auto Mode and use manual operation by selecting a fan speed.
The humidifier has turned back on after I turned it off.	5 minutes after turning off or water tank is empty, humidifier enters Auto Dry Mode. See page 8.	Allow the unit to run through Auto Dry Mode cycle to maintain a clean environment. Exit through APP or selecting the off button again.
Visible residue or discolor on the humidifier or wick filter.	The humidifier is safe to use with tap water. Water impurities are captured in the filter so visible residue is normal & shows correct operation.	See maintenance and cleaning instructions on page 13.
I cannot connect my humidifier to Wi-Fi.	<p>The humidifier is too far from your phone and router during the set up.</p> <p>The Blueair App is not up to date.</p> <p>The router is not on or has no connection. The router is not using a standard connection.</p>	<p>1. Ensure that your phone, humidifier and Wi-Fi router are in the same room and in close distance during initial set up (follow the app for exact distance instructions). Once you have successfully paired your humidifier you can place it at your desired location.</p> <p>2. Make sure your humidifier is plugged in and powered on.</p> <p>Open your App Store in your phone and ensure you have the latest Blueair app version.</p> <p>Ensure the following before trying to connect your product again:</p> <ol style="list-style-type: none">1. Internet is currently running2. You are using a 2.4GHz network.3. Deactivate VPN.
	Bluetooth is deactivated.	Ensure Bluetooth is enabled on your phone.
My humidifier has lost connection.	Temporary Wi-Fi disturbances. New Wi-Fi settings or router.	If your humidifier does not re-connect by itself after a few minutes: <ol style="list-style-type: none">1. Open the Blueair app.2. Select your humidifier and go to Product Settings.3. Delete the humidifier.4. Go back to the home screen and select "Connect Product". Follow the connection instructions on the product.

For more information and troubleshooting tips, please check the Support page on www.blueair.com