

# User Manual

 **Blueair**



SCAN FOR SUPPORT

## Blueair PetAir Pro P3i



0112806000

**Please read this user manual carefully and keep it for future reference.**

**You can view the latest version of the user manual at [www.blueair.com](http://www.blueair.com).**

Safety Instructions .....	4
PetAir Purifier.....	6
Product Map.....	7
Getting Started .....	9
Device Controls .....	10
Daily Operation.....	11
Filter Replacement Instructions .....	13
Hair Collection Box Cleaning and Maintenance.....	15
Pre-Filter Cleaning and Maintenance .....	16
Air Quality Indicator .....	18
Maintenance Information .....	19
Moving the Device.....	20
Troubleshooting .....	21
Disposal, Support and Warranty.....	24
Regulatory Information.....	25

# Safety Information



## General Safety Instructions

The PetAir purifier is an appliance for indoor use only. Take the necessary precautions to reduce the risk of fire, electric shock or injury.

- This appliance is not intended for use by persons (including children) with reduced physical, sensory or mental capabilities, or lack of experiences and knowledge, unless they have been given supervision or instruction concerning the use of the appliance by a person responsible for their safety.
- Supervise children to ensure that they do not play with the appliance.
- Children shall not clean and maintain this product.
- Ensure that the power adapter and power plug are not at risk of getting damaged.
- If the appliance is damaged or malfunctions, turn it off, disconnect it from the power supply and contact the Blueair customer support.
- The power plug must be firmly inserted in the power socket.
- When disconnecting the appliance from power supply, either pull on the power adapter, or pull on the power plug.
- Use the adapter (ZD036B240150US) provided with your PetAir purifier to plug directly and firmly into an appropriate electrical outlet.
- Do not use an extension cord or a power strip. Refer to the rating label on your appliance.
- Do not alter the power plug in any way. If the plug does not fit into the outlet, contact qualified personnel to install the proper outlet.
- Do not use the included power adapter for anything else but the appliance.
- Do not allow objects to enter or block the air inlets/outlets as this can cause electric shock or damage the appliance.
- Do not place any objects on top of or directly against the appliance.
- Do not sit, stand, climb, or hang on this device.

- Do not use the appliance outdoors or in wet environments such as bathrooms or pool areas.
- Keep the appliance and power plug away from water and other liquids.
- Keep the appliance, including the power adapter, at a safe distance from heated surfaces and open fire.
- Keep the appliance and power plug away from chemicals such as pesticides and deodorants.
- Never clean with gasoline, chemical solvents, or corrosive materials as these agents may damage the PetAir purifier.
- Place the PetAir purifier on the floor or a stable surface to prevent tipping.
- Always turn off and disconnect the appliance from the power supply before moving the unit, changing filters, cleaning or carrying out maintenance.
- DO NOT allow pets to chew on or swallow any parts.
- Dispose of all packaging materials properly. Keep away from children and pets.
- If your Blueair appliance is found to be defective, we will replace it with the same or a similar model at no cost, per the warranty terms. Please use caution attempting repairs yourself, as this presents the danger of electrical shock or injury.
- To reduce risk of fire, electric shock or injury to persons, do not use replacement parts that have not been recommended by manufacturer (e.g. parts made at home using a 3D printer).
- To avoid risk of fire or electric shock, the appliance should only be used with the correct input voltage that it is rated for, refer to your rating label on the device.
- This product complies with the maximum allowable concentration of ozone of 0.050 parts per million by volume (ppmv) in a 24-hour period.

# Product Introduction

<b>Product Name</b>	<b>Regulatory Model Number</b>
Blueair PetAir Pro P3i	2712716000

This product comes with integrated controls and built-in sensor. Use the control panel on the appliance or the Blueair App to adjust the settings of your product.

## Performance Optimization Suggestions

- Ensure that the size of the room where the purifier is placed does not exceed the recommended capacity.
- Position the purifier in an area where air can freely flow in and out, ensuring proper circulation.
- Maintain a distance of at least 4 inches (10 cm) between the purifier and any other object to ensure proper air circulation.
- Keep doors and windows closed while the purifier is in operation.
- Replace the filter when the Filter Replacement indicator light turns red on the control panel.
- Refer to the maintenance instructions in this user manual for proper care.
- To prevent accidental activation of smart mode, ensure the total weight of objects placed on the appliance does not exceed 1.1lb.

# Product Diagram

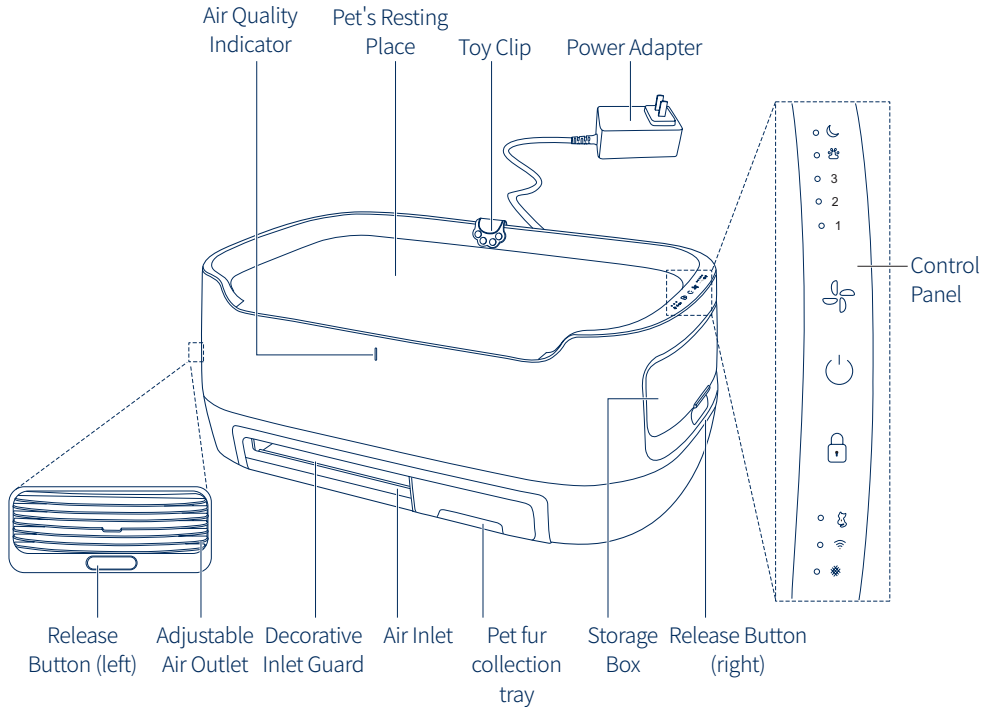

# Replacement Filter & Fur Collection System

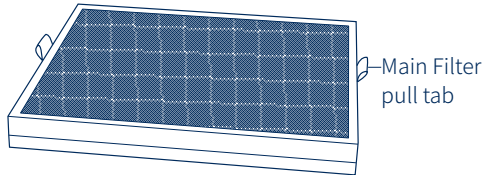

Main Filter

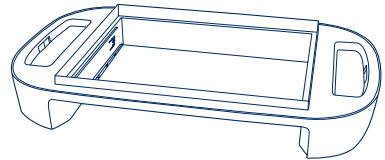

Main Filter Holder

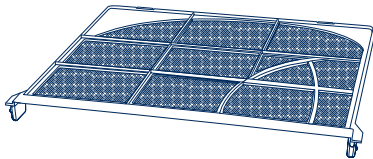

Pre-filter

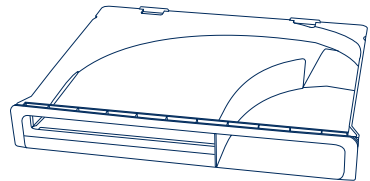

Fur collection module

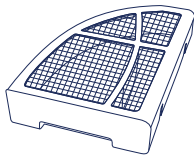

Pet fur collection tray

# Getting Started

## Connect to the Blueair app

Connecting to the Blueair app allows you to control the air purifier remotely and monitor filter usage. The app offers additional features to the device.

- Download the Blueair app from App Store or Google Play.
- Create or sign into your Blueair account.
- Follow the instructions to complete app pairing.



## First Time Connecting Tips

Turn on your air purifier. Press and hold the Fan Speed button for 5 seconds to prepare the air purifier for pairing. Once the Wi-Fi indicator is blinking, it is ready to be paired with your app. Make sure you are using a visible Wi-Fi network. VPN (Virtual Private Network) should be deactivated while using the Blueair app.



First-time pairing requires enabling the phone's Bluetooth function and placing the phone near the air purifier (recommended within 3 feet).



Note: The purifier can only connect to 2.4 GHz Wi-Fi. If your router supports dual-band, be sure to select the 2.4 GHz band.



If you choose not to connect the product, the Wi-Fi can be turned off. Long press the Fan Speed button for 15 seconds and then release, the Wi-Fi will be turned off.

Keep your purifier within 15 feet of your Wi-Fi router when connecting the product for the first time.



# Control Panel

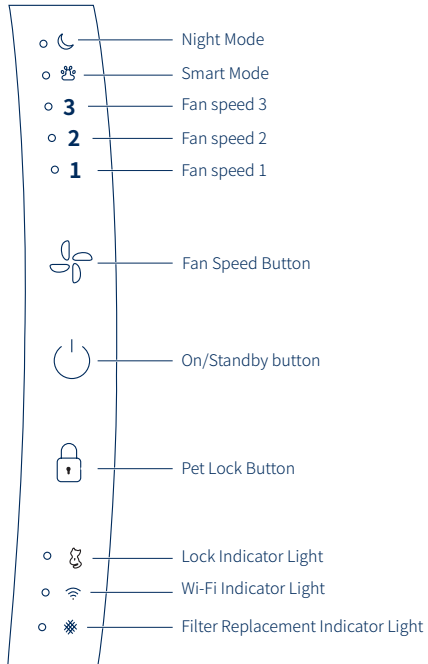





# Control Panel Icons

## On/Standby Button

Click **twice** to turn on and off the device.

## Connecting to Wi-Fi

- Press and hold the fan speed button  for 5 seconds, to begin pairing the Blueair PetAir Pro purifier to your phone.
- The Wi-Fi indicator light is off,  if you have not previously paired your mobile phone.
- The Wi-Fi indicator light  flashes if the appliance is trying to connect.
- The Wi-Fi indicator light  is normally on, if Wi-Fi is connected.

## Fan Speed Button

Adjust fan to 1-2-3, Smart Mode and Night Mode.

## Smart Mode Indicator

Auto-adjusts the fan speed based on indoor air quality and pet weight.

If a pet is lying on the bed it goes into Silent Mode and the UI will lock automatically.

When it detects the pet leaving the bed it adjusts the fan speed according to the indoor air and UI unlock automatically.

## Night mode

Night mode sets the device to the lowest fan speed and brightness for night time use.

## Lock Button

Press and hold the lock button for 2 seconds until LED lights flashes to activate/deactivate the lock function. When the key lock is activated, all buttons are locked, and the lock indicator light turns on  to prevent accidental operation.

## **Filter Replacement** ❄️

When the filter replacement indicator turns red it means that the filter has expired. After replacing it with a new filter, always reset the filter replacement indicator light by pressing and holding the fan setting button and lock button for 15 seconds until LED lights flashes. (see filter replacement section).

## **Factory reset**

Long press On/Stanby button for about 15 seconds. All the LEDs of the interface light up and blink. Then release. Factory Reset will start in 10 seconds.

After factory reset, the air purifier restarts with default configuration and will go into Standby mode.

## **Air Outlet Louvers**

The air outlet on the left side of the PetAir purifier is equipped with louvers to set the wind direction. Set the desired wind direction manually.

## **Toy Clip**

This clip can be used to secure toys, such as cat teasers. The toy clip is provided as an accessory for this appliance. Please do not use the toy clip for other purposes.

## **Decorative inlet guard**

This Inlet guard will avoid pet toys, such as pet balls from entering.

# Filter Replacement Instructions

## Cleaning and Changing the Filters

**Important Tips!** Always turn off and disconnect the device from power supply before changing filters, cleaning or carrying out maintenance.

Your filter are non-washable and non-recyclable.

Failure to replace the filter when prompted may result in changes to product performance.

## Filter Replacement

The purifier uses a patented RealTrack algorithm to calculate the remaining life of the filter. When it is time to replace the filter, the filter replacement indicator  will turn red on the control panel.

The recommended time for filter change is 9 - 12 months.

Easily order Blueair filters from [www.blueair.com](http://www.blueair.com) or via the app or sign up for Blueair filter subscription. The serial number and model name can be found at the bottom of the top part. (Detach the top part and see the bottom)

## Replacing the Main Filter

### Step 1

Press the two release buttons and lift the top part of the device.

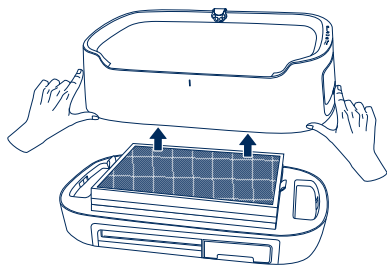

### Step 2

Take hold of the two tabs of the main filter and lift it out. Dispose of the main filter.

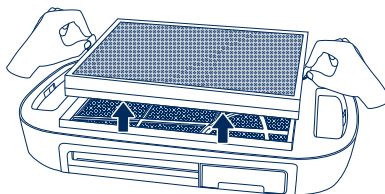

### Step 3

Install the new filter correctly into the filter unit according to the direction indicated on the filter frame.

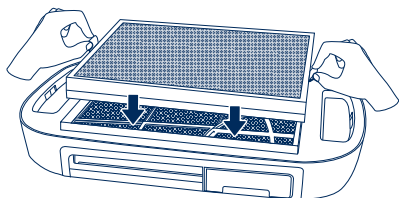

**Note!** Before using a new filter, remove the plastic film.

### Step 4

After replacing the main filter, reattach the top part of the device.

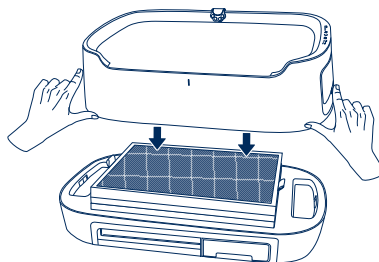

**Note!** After replacing it with a new filter, always reset the filter replacement indicator light by pressing and holding the fan setting button and lock button 15 seconds until LED lights flashes.

# Pet fur collection tray cleaning

## Step 1

Double click the On/Off button  to turn the device off and unplug the power adapter.

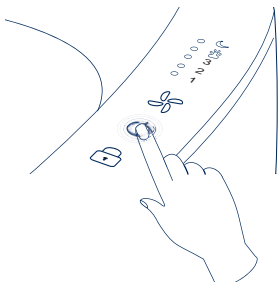

## Step 2

Pull out the hair collection box at the bottom of the device.

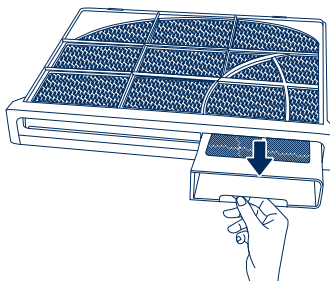

## Step 3

Open the hair collection box and dump out the pet hair inside.

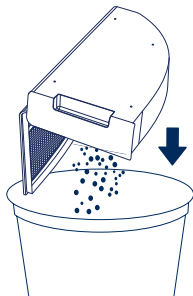

## Step 4

Use a soft brush or vacuum using a brush attachment(not included) to clean the prefilter.

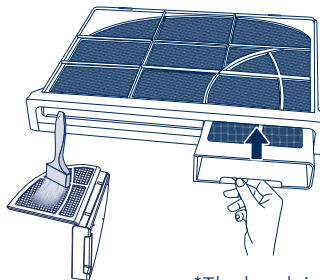

\*The brush is not included

# Pre-Filter Cleaning and Maintenance

## Pre-Filter Cleaning

### Step 1

Double click the On/Off button  to turn the device off and unplug the power adapter.

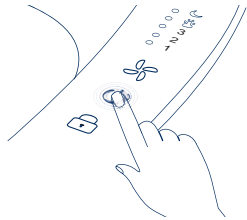

### Step 2

Pull out the hair collection unit from the bottom of the device.

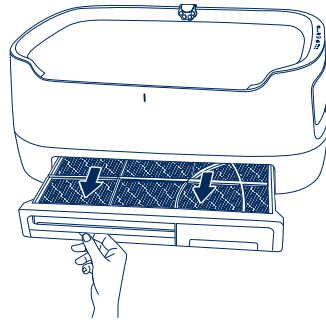

### Step 3

Gently lift the pre-filter.

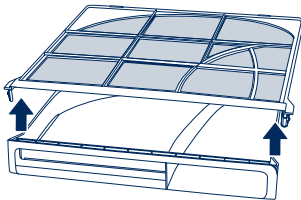

### Step 4

Use a soft brush or vacuum using a brush attachment(not included) to clean the prefilter.

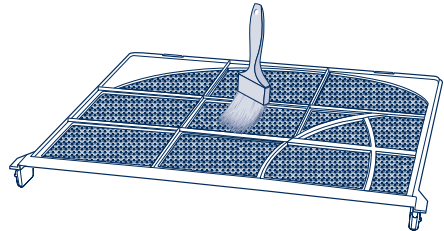

### Step 5

Reattach the cleaned pre-filter to the base of the hair collection unit.

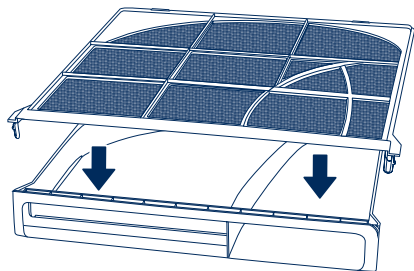

### Step 6

Reinstall the hair collection unit to its original position.

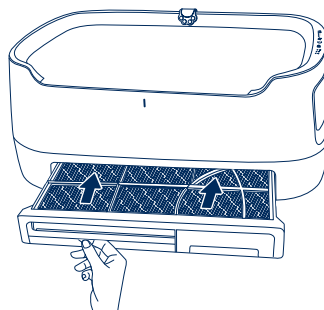

# Air Quality Indicator

## Air Quality Conditions

The PetAir pet air purifier is equipped with a laser particle sensor to monitor the concentration of fine particulate matter (including PM1, PM2.5, and PM10) in real-time.

In addition, the purifier includes a TVOC (Total Volatile Organic Compounds) sensor to detect levels of indoor volatile gases.

The LED indicator uses a five-color display system for excellent air quality.



Excellent



Good



Moderate



Polluted



Severely Polluted

# Maintenance Information

To keep your PetAir purifier in optimal condition, regular maintenance is essential. Please follow these recommendations when cleaning your appliance.

**Warning:** RISK OF ELECTRIC SHOCK – All servicing instructions are for use by qualified personnel only. To reduce the risk of electric shock, do not perform any maintenance other than that contained in the user manual unless you are qualified to do so. Otherwise, do not perform any maintenance other than that contained in the user manual.

## General Information

- Before maintenance, disconnect the PetAir purifier from main power supply.
- Never clean your PetAir purifier with gasoline, chemical solvents or corrosive materials as these agents may damage the appliance.
- Do not wash the main filter; it is not washable or reusable.

## Cleaning

- Cleaning and maintenance by the user must not be carried out by children.
- Do not use any aggressive cleaning agents or solvents, hard brushes, metal or sharp objects to avoid damaging the devicez.
- Wipe the exterior of the PetAir purifier with a soft, clean cloth.
- Clean the inside of the filter housing with a soft, clean cloth.
- Clean and check the power adapter and power plug for wear and damages.
- We recommend cleaning the pre-filter and hair collection box with a soft brush (soft brush not included).
- Never immerse the motor section of your PetAir purifier in water or other liquids during cleaning. Never hold the product under running water.
- Make sure that no water penetrates the PetAir purifier.

# Moving the Device

**Important Tips!** When moving the appliance, ensure the power adapter and power cord are unplugged.

- Place your hands left and right under the device.
- Lift the device straight up and carry it carefully.

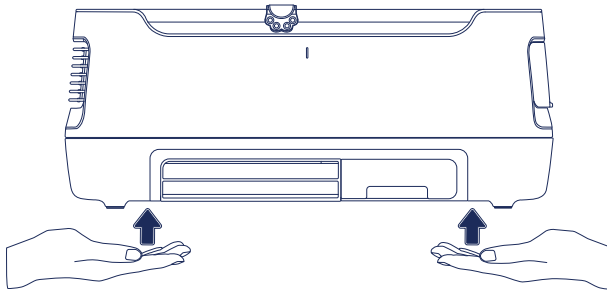

# Troubleshooting

Issue	Potential Causes	Try This
Red icon  on the operating panel of the PetAir purifier	It is time to change the filter	Change the filter according to the instructions in this user manual Reset the filter replacement indicator light by pressing and holding the fan setting button and lock button for 15 seconds (see filter replacement section).
	If the PetAir purifier is set to high-speed level it produces more noise	At a lower fan speed, the PetAir purifier will have less noise.
Purifier makes too much noise	Plastic film is still on the filter	Make sure that the plastic film is removed from the filter.
	If the filter is too dirty and clogged, the purifier will not get sufficient airflow which may result in increased noise	Unplug your purifier and carefully clean the main filter, pre-filter and pet fur collection tray.

Purifier is disconnected.	Temporary WiFi disturbances or new WiFi or router settings	Open the Blueair App, select your purifier and go to product settings; delete the purifier; go back to the home screen, select "Connect Product" and follow the connection instructions
The indoor air quality is not improving	The indoor air quality remains polluted	<ol style="list-style-type: none"> <li>1. Unplug the air purifier and wait for approximately 30 seconds.</li> <li>2. Make sure that there are no objects or dust around the air quality sensors at the back of the air purifier.</li> <li>3. Vacuum the area to clean the inlet for the sensor.</li> <li>4. Reconnect the power adapter.</li> <li>5. Double click the on/off button.</li> </ol> <p>If the air quality does not improve with the use of the air purifier and with ventilation, please contact us.</p>
	The air quality sensor is dusty and shows incorrect levels	

PetAir Purifier cannot be connected.	The PetAir purifier is too far from your phone and router during setup	Ensure that your phone, PetAir purifier and Wi-Fi router are in the same room and in close distance during initial set up; once you have successfully paired your PetAir purifier you can place it at your desired location
		Make sure that your PetAir purifier is plugged in and powered on
	The Blueair App is not up to date	Download the latest Blueair App version from the App store or Google Play
	The router is not open or disconnected, or a standard connection is not used.	Ensure that your Internet is currently running
		Ensure that you are using a 2.4GHz network
	Deactivate VPN	
Bluetooth® is deactivated	Ensure Bluetooth® is enabled in your smartphone's settings	
Excessive airflow around the device	The fan speed setting is too high	Set a lower fan speed

For more information and troubleshooting tips, please check the support page on [www.blueair.com](http://www.blueair.com).

# Disposal, Support and Warranty

## Disposal and Recycling

The PetAir purifier should be disposed of or recycled as electrical waste and the filter should be disposed of as regular waste. If you have questions regarding the disposal and recycling of your device, please contact your local recycling facility or your Blueair retailer.

## Help and Support

If you have questions about your product, please visit [www.blueair.com](http://www.blueair.com) or contact your local Blueair retailer.

## Limited Warranty

The PetAir purifier has a limited warranty of 3 years.



# Regulatory Information

**WARNING:** Changes or modifications to this appliance not expressly approved by the party responsible for compliance could void the user's authority to operate the equipment.

**Note!** This equipment has been tested and found to comply with the limits for a Class B digital device, pursuant to Part 15 of the FCC Rules. These limits are designed to provide reasonable protection against harmful interference in a residential installation. This equipment generates, uses and can radiate radio frequency energy and, if not installed and used in accordance with the instructions, may cause harmful interference to radio communications.

However, there is no guarantee that interference will not occur in a particular installation. If this equipment does cause harmful interference to radio or television reception, which can be determined by turning the equipment off and on, the user is encouraged to try to correct the interference by one or more of the following measures:

- Reorient or relocate the receiving antenna.
- Increase the separation between the equipment and receiver.
- Connect the equipment into an outlet on a circuit different from that to which the receiver is connected.
- Consult the dealer or an experienced radio/TV technician for help.

This device complies with Part 15 of the FCC Rules. Operation is subject to the following two conditions:

- This device may not cause harmful interference.
- This device must accept any interference received, including interference that may cause undesired operation.

This Class B digital apparatus complies with Canadian ICES-003.

This device contains licence-exempt transmitter(s)/receiver(s) that comply with Innovation, Science and Economic Development Canada's license-exempt RSS(s). Operation is subject to the following two conditions: (1) This device may not cause interference, and (2) This device must accept any interference, including interference that may cause undesired operation of the device.

FCC/ISED RF Exposure Information: This equipment should be installed and operated with a minimum distance of 4 inches (10 cm) between the radiator and your body.