

*get started*

INSTANT POT® **PRO PLUS**  
USER MANUAL

Instant™

# Table of contents

Welcome! .....	3
IMPORTANT SAFEGUARDS.....	4
Product, parts and accessories .....	9
Get started.....	11
Cooking from the Instant Brands Connect App.....	14
Pairing with the Instant Brands Connect App .....	15
Control panel .....	16
Settings .....	19
Pressure cooking .....	20
Releasing pressure .....	21
Pressure control features.....	23
Cooking .....	28
About Canning.....	31
Canning 101.....	32
Cooking .....	33
Care, cleaning and storage .....	43
Troubleshooting .....	48

# Welcome!

Thank you for purchasing your new Instant Pot® Pro Plus Pressure Cooker. We hope you enjoy cooking with it for years to come.

## Register your product

Help us keep in touch, in case we need to reach you. Register your product at [instantbrands.co.uk/product-registration](https://instantbrands.co.uk/product-registration).

## Contact Us

When you have questions about your new Instant Pot, we're here to help.







[instantbrands.co.uk/support/](https://instantbrands.co.uk/support/)

[UKSupport@instantbrands.com](mailto:UKSupport@instantbrands.com) (if located in the UK)

[EUSupport@instantbrands.com](mailto:EUSupport@instantbrands.com) (if located in the EU)

+44 (0) 3331 230051

## Product Specifications

				
Model: Pro Plus 60	220-240 V ~ 50-60 Hz	1200 W	5.7 Litres	15.54 lb / 7.05 kg
	Pro Plus 60			
	icm: 33.5L x 33.1W x 32.3H			

## Find your model name and serial number

Find the **model name** on the silver rating label on the back of the multicooker base, near the power cord. The **serial number** is located on a white sticker beside the rating label.

## Product specifications

Model	Wattage	Power	Volume	Weight	Dimensions
Pro Plus	1200W	220-240V~ 50/60 Hz	5.7 Litres	7.05kg	cm: 33.5L x 33.1W x 32.3H

### **⚠ WARNING**

#### **Safety Instructions**

At Instant™, we want you to feel comfortable using our products. This Instant Pot Pro Plus was designed with you and your safety in mind.

**Read all instructions before using and only use this appliance as directed. Failure to follow these Important Safeguards may result in personal injury and/or property damage and will void your warranty.**

*When using electrical appliances, basic safety precautions should always be followed to reduce the risk of fire, electric shock, and injury to persons.*

## **⚠ IMPORTANT SAFEGUARDS**

---

## READ ALL INSTRUCTIONS

#### **Placement**

**DO** place the appliance on a countertop only. Always operate the appliance on a stable, noncombustible, level surface.

**DO** make sure all parts are dry and free of food debris before placing the cooking pot on the cooker base.

**DO NOT** place the appliance on or close to a hot gas or electric burner, or a heated oven.

**DO NOT** use the appliance near water or flame.

**DO NOT** use outdoors. Keep out of direct sunlight.

**DO NOT** place on anything that may block the vents on the bottom of the appliance.

## **⚠ WARNING**

### **General Use**

**The removable inner cooking pot is extremely hot during use, and can be extremely heavy when full of ingredients.**

**DO** use oven mitts when handling the inner cooking pot and removing accessories.

**DO** place hot accessories on a heat-resistant surface or cooking plate.

**DO** use care when lifting the cooking pot from the cooker base to avoid burn injury.

**DO** use extreme caution when the cooking pot contains hot food, hot oil or other hot liquids.

**DO** use only the Instant Brands lid that came with this cooker base. Using any other pressure cooker lids may cause personal injury and/or property damage.

**DO NOT** use the appliance without the removable inner cooking pot installed.

**DO NOT** touch the metal portion of the lid, the appliance's hot surfaces, or any accessories during or immediately after cooking because they will be hot. Only use the side handles for carrying or moving.

**DO NOT** use this appliance for deep frying or pressure frying with oil.

**DO NOT** move the appliance while it is in use and use extreme caution when disposing of hot grease.

**DO NOT** allow children or persons with reduced physical, sensory or mental capabilities to operate this appliance. Close supervision is necessary when any appliance is used by or near children and persons with reduced physical, sensory or mental capabilities. Children should not play with this appliance.

**DO NOT** use the appliance for anything other than household use. It is not intended for commercial use.

**DO NOT** leave the appliance unattended while in use.

### **Pressure Cooking**

This appliance cooks under pressure. **DO NOT** open while under pressure. Allow the appliance to depressurise naturally or release all excess pressure before opening. Inappropriate use may result in burns, personal injury and/or property damage.

**DO** make sure the appliance is properly closed before operating.

**DO** check that the steam release valve is installed.

## **⚠ WARNING**

**DO** use the Instant Brands lid when pressure cooking. *For instructions on how to use the lid, see the User Manual.*

**DO** turn the appliance off if steam escapes from the steam release valve and/or float valve in a steady stream for longer than 3 minutes. If steam escapes from the sides of the lid, turn the appliance off, wait for it to depressurise/cool, and make sure the sealing ring is properly installed.

**DO** check the steam release valve, steam release pipe, anti-block shield and float valve for clogging before use. For instructions on how to clean these parts, see the User Manual.

**DO NOT** remove the pressure cooking lid with unprotected hands.

**DO NOT** attempt to force the lid off the Instant Pot cooker base.

**DO NOT** move the appliance when it is under pressure.

**DO NOT** cover or obstruct the steam release valve and/or float valve with a cloth or other objects.

**DO NOT** attempt to open the appliance until it has depressurised, and all internal pressure has been released. Attempting to open the appliance while it is still pressurised may lead to sudden release of hot contents and may cause burns or other personal injuries and/or property damage.

**DO NOT** place your face, hands or exposed skin over the steam release valve or float valve when the appliance is in operation or has residual pressure, and do not lean over the appliance when removing the lid.

### **Overfill During Pressure Cooking**

Overfilling may cause a risk of clogging the steam release pipe and developing excess pressure.

**DO NOT** fill the inner cooking pot over the line labeled 'PC MAX – 2/3'.

**DO NOT** fill the inner cooking pot over the line labeled '– 1/2' when cooking foods that expand during cooking such as rice, dried beans or dried vegetables.

**DO** exercise extreme caution when cooking and venting food(s) such as applesauce, cranberries, pearl barley, oatmeal, split peas, noodles, etc. as these foods may foam, froth, or spatter, and may clog the steam release pipe, valve, and/or steam release handle.

**DO NOT** fill the inner pot higher than the "PC MAX- 1/2" line when

## **⚠ WARNING**

cooking these foods. Failure to follow this warning may lead to personal injury and/or property damage and may void your warranty.

**DO NOT** place oversized foods into the inner cooking pot as they may cause risk of fire and/or personal injury and/or property damage.

**DO** check that the sealing ring is properly installed.

### **Accessories**

**DO** use only accessories or attachments authorised by Instant Brands. The use of parts, accessories or attachments not recommended by the manufacturer may cause a risk of personal injury, property damage, fire and/or electric shock.

**DO** use only the authorised stainless-steel inner cooking pot for the Pro Plus to reduce the risk of pressure leakage.

**DO** only replace the sealing ring with an authorised Instant Brands sealing ring to prevent personal injury and damage to the appliance.

**DO NOT** use the included accessories in a microwave, toaster oven, convection or conventional oven, or on a ceramic cooktop, electric coil, gas range or outdoor grill.

### **Care and Storage**

**DO** let the appliance cool to room temperature before cleaning or storage.

**DO NOT** store any materials, other than the multicooker cooking pot, in the cooker base when not in use.

**DO NOT** place any combustible materials in the cooker base, such as paper, cardboard, plastic, Styrofoam or wood.

### **Power Cord**

A short power-supply cord is used to reduce the risk resulting from it being grabbed by children, becoming entangled in, or tripping over a longer cord. **WARNING:** Spilled food can cause serious burns. Keep appliance and cord away from children. Never drape cord over edge of counter, never use outlet below counter, and never use with an extension cord.

**DO NOT** let the power cord touch hot surfaces or open flame, including the stovetop.

## **⚠ WARNING**

**DO NOT** use with power converters or adapters, timer switches or separate remote-control systems. This appliance has an earthed plug. To reduce the risk of electric shock: **ONLY** plug the power cord into a earthed electrical outlet.

**DO NOT** remove EARTH.

If the unit includes a detachable power cord:

To connect, always attach the power cord to the appliance first, then plug the power cord into the wall outlet.

### **Electrical Warning**

The cooker base contains electrical components that are an electrical shock hazard. Failure to follow these instructions may result in electric shock. To protect against electrical shock: disconnect, select **Cancel**, then remove plug from power source. Always unplug when not in use, as well as before adding or removing parts or accessories, and before cleaning. To unplug, grasp the plug and pull from the outlet. Never pull from the power cord.

**DO** regularly inspect the appliance and power cord.

**DO NOT** operate the appliance if the power cord or plug is damaged, or after the appliance malfunctions or is dropped or damaged in any manner. For assistance, contact Customer Care by email at **UKSupport@instantbrands.com** (if located in the UK) or **EUSupport@instantbrands.com** (if located in the EU) or by phone at **+44 (0) 3331230051**. **DO NOT** attempt to repair, replace or modify components of the appliance, as this may cause electric shock, fire or personal injury, and will void the warranty.

**DO NOT** tamper with any of the safety mechanisms, as this may result in personal injury and/or property damage.

**DO NOT** put liquid or food of any kind into cooker base without the inner cooking pot.

**DO NOT** immerse power cord, plug or the appliance in water or other liquid.

**DO NOT** use the appliance in electrical systems other than 220-240V~ 50/60Hz.

**DO NOT** clean the appliance by rinsing it under a faucet.

# SAVE THESE INSTRUCTIONS

# Product, parts and accessories

Before using your new Instant Pot Pro Plus, make sure everything is accounted for, then see **Care, cleaning and storage: Removing and installing parts** to find out how everything fits together.

## Top of lid

### Steam release assembly

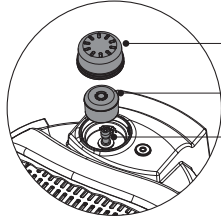

Steam release cover

Steam release valve

Steam release pipe

Lid fin  
Lid handle

QuickCool protective cover

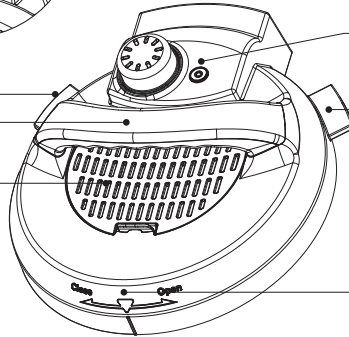

Float valve

Lid fin

Lid position markers

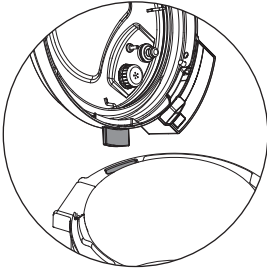

Instant Tip: Stand the pressure cooking lid up to keep it off your countertop. Insert the left or right lid fin into corresponding lid holders on the base to stand it up and save some space!

## Bottom of lid

Sealing ring

Sealing ring rack

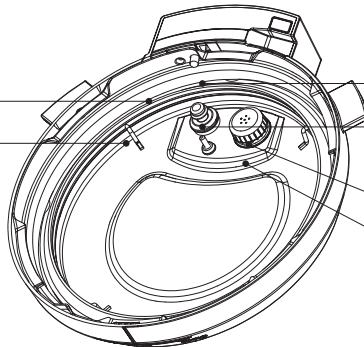

Locking pin

Silicone cap  
(bottom of float valve)

Anti-block shield

Steam release pipe  
(beneath the anti-block shield)

*Illustrations in this document are for reference only and may differ from the actual product. Always refer to the actual product.*

# Product, parts and accessories

## Cooking pot

Easy Grab silicone handles

Fill line indicators

Flat bottom

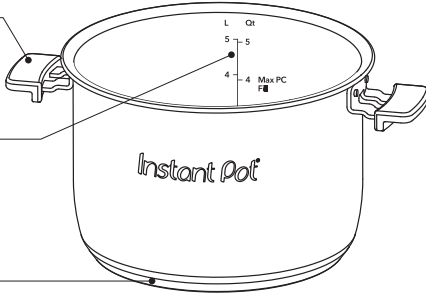

Instant Tip: Stove top and oven-friendly up to 204°C

The cooking pot features a cookware-grade impact bonded tri-ply bottom, which sounds complicated, but really just means you can use it just about anywhere – from the multicooker base to any electric, ceramic, gas or induction cooktop.

## Multicooker base

Outer pot

Condensation rim

Control panel

Black stainless-steel exterior

Lid holder

Condensation collector (rear)

Multicooker handle

Heating element (interior)

Cord holder (rear)

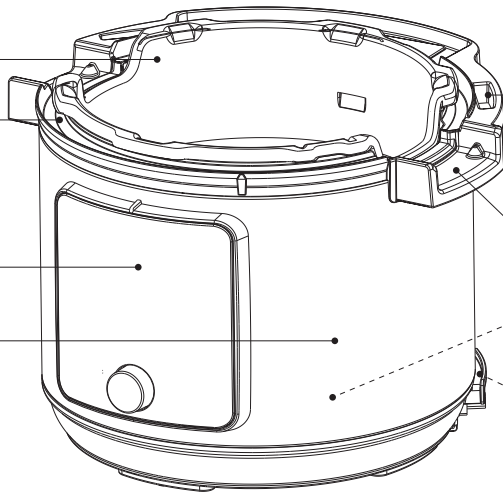

## Accessories

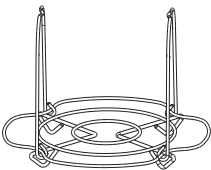

Steam rack

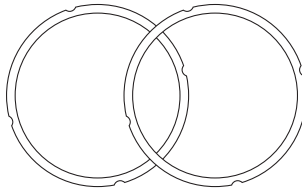

Extra sealing ring

*Illustrations in this document are for reference only and may differ from the actual product. Always refer to the actual product.*

# Get started

## Initial set up

- 01** Pull that Instant Pot Pro Plus out of the box!
- 02** Remove the packaging material and accessories from in and around the multicooker and make sure all the parts are accounted for. See **Product, parts and accessories** for a full parts breakdown.  
Make sure to check under the cooking pot!
- 03** Wash the cooking pot in a dishwasher or with hot water and dish soap. Rinse it well with warm, clear water and use a soft cloth to thoroughly dry the outside of the cooking pot.
- 04** Wipe the heating element with a soft, dry cloth to make sure there are no stray packaging particles left in the multicooker base.  
Don't remove the safety warning stickers from the lid (unless specified on the sticker!) or the labels from the back of the multicooker base.
- 05** You may be tempted to put the Pro Plus on your stovetop – *but don't do it!* Place the multicooker base on a stable, level surface, *away* from combustible material and external heat sources.

## Is something missing or damaged?

Get in touch with a Customer Care Advisor by email at [UKsupport@instantbrands.com](mailto:UKsupport@instantbrands.com) (if located in the UK) or [EUsupport@instantbrands.com](mailto:EUsupport@instantbrands.com) (if located in the EU) and we'll happily make some magic happen for you!

### CAUTION

Read the **Important safeguards** before using the appliance. Failure to read and follow those instructions for safe use may result in damage to the appliance, property damage or personal injury.

**DO NOT** place the appliance on a stovetop or another appliance. Heat from an external source will damage the appliance.

To avoid risk of property damage and/or personal injury, **DO NOT** place anything on top of the appliance, and **DO NOT** cover or block the steam release assembly or anti-block shield, located on the appliance lid.

# Get started

## Initial test run (water test)

Before using your new Pro Plus for the first time, you must perform a pressure cooking test run to ensure everything is working correctly.

### Stage 1: Setting up the Pro Plus for pressure cooking

**01** Remove the cooking pot from the multicooker base and fill it to the first line (1) with water.

**02** Insert the cooking pot into the multicooker base.

**03** Connect the power cord to a 220-240 V power source.

The display shows **OFF**.

**04** Place and close the lid as described in **Pressure control features: Pressure cooking lid**.

The lid automatically seals for pressure cooking.

### Stage 2: "Cooking" (...but not really, this is just a test!)

**05** Touch **Pressure Cook**.

**06** When the **minutes field** flashes, turn the dial to adjust the cook time to 5 minutes (**00:05**).

Customisations are saved to the Smart Programme when cooking begins.

**07** Touch the Venting field to toggle between **Natural**, **Pulse** and Quick release options.

Select **Quick** for a quick pressure release after the test finishes. See **Releasing pressure** for more information.

**08** Touch **Keep Warm** to turn automatic warming off after the test finishes.

**09** Touch **Start** to begin.

The display shows **On** and the cooking progress bar shows **Pre-heating**.

### Stage 3: Releasing pressure

When the Smart Programme finishes, the quick release icon flashes until venting is finished

**10** Check the **pressure indicator** on the control panel to make sure the lid is safe to open, then carefully open and remove the lid as described in **Pressure control features: Pressure cooking lid**.



Please read the **Pressure Control Features (pressure indicator)** section on page 29.

**11** Using proper hand protection, remove the cooking pot from the multicooker base, discard the water and thoroughly dry the cooking pot.

**You're ready start cooking with your Instant Pot® Pro Plus!**

# Get started

## CAUTION

Pressurised steam releases through the top of the steam release valve. Keep exposed skin away from the steam release valve to avoid burn injury.

## DANGER

**DO NOT** attempt to remove the lid while the pressure indicator is on and **NEVER** attempt to force the lid open. Contents are under extreme pressure. Pressure indicator light must be off before attempting to remove the lid. Failure to follow these instructions may result in serious personal injury and/or property damage

## CAUTION

The cooking pot will be hot after cooking. Always use appropriate heat protection when handling a hot cooking pot to avoid burn injury.

# Cooking from the Instant Brands Connect App

Make cooking simple and easy when you control your Instant Pot® Pro Plus using the Instant Brands Connect App from your mobile device. You have full control of the cooking programmes, plus access to 1000+ interactive guided cooking recipes.

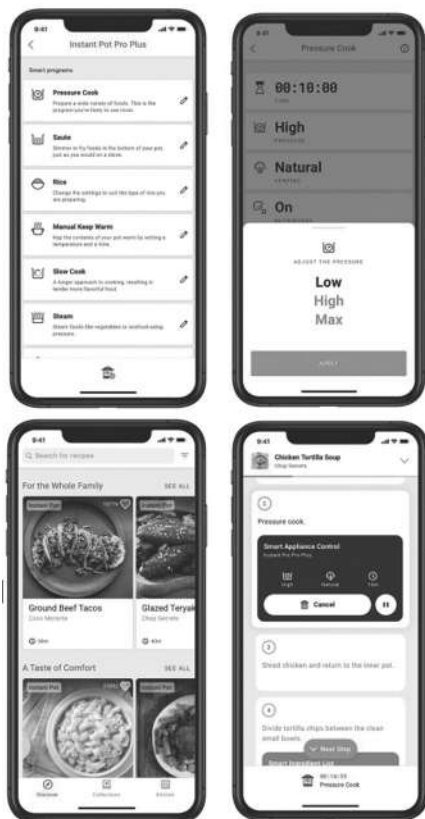

fresco

## Control cooking programmes

The Pro Plus includes 9 smart programmes and you can control each of them and then monitor cooking within the App. You can use the default cooking settings, or choose your own settings for things like time, pressure level, temperature and venting type.

## Guided recipes

The Instant Brands Connect App includes over 1000 delicious recipes. But unlike standard recipes, the App can interactively guide your cooking on the Pro Plus. The App will start the cooker, and control the settings exactly as the recipe specifies. All you have to do is prepare the ingredients and add them to the cooker.

# Pairing with the Instant Brands Connect App

You can control your Pro Plus with the Instant Brands Connect App using your mobile device.



## To download the App, either:

- Scan the QR code, or;
- Search "Instant Brands Connect" in the Apple Store or the Google Play Store.

To get started, you'll need to create an account.

## Requirements for pairing

You can use these compatible mobile devices to pair via WiFi and bluetooth:

- Android version 5.0 or later.
- iOS version 12.0 or later.

The Instant Pot can only connect to a 2.4GHz WiFi network. Bluetooth must be turned on to pair the Instant Pot.

## Follow the steps below to start the pairing process.

Before you start, make sure you:

- Download the Instant Brands Connect App and create an account if you don't already have one.
- Know your home WiFi network name and password.
- Make sure your Bluetooth setting is set to On.
- Make sure your Pro Plus is plugged in and not currently cooking. It should display OFF.
- Make sure you have your mobile device near the Pro Plus.

**01** Open the App and select the Appliances section, then select Add an Appliance.

**02** From the list of appliances, select "Instant Pot Pro Plus".

**03** Follow the instructions in the App to start the pairing process.

When you're done, you're set to control your Pro Plus from your App, and take advantage of even smarter, easier cooking!

**Note:** The Initial Water Test run can be done using the mobile app. Ensure the device is connected using the steps above before starting the test.

# Control panel



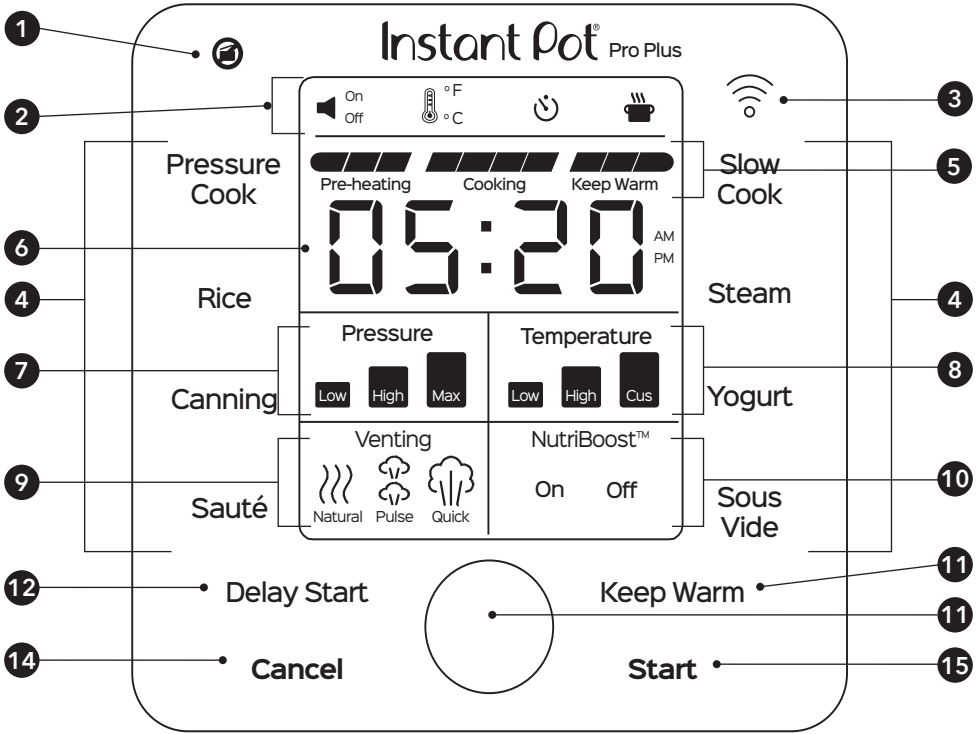

The Pro Plus has a touch screen control panel that's easy to use and understand.



1	<b>Pressure indicator</b>	Lights up when there is pressure in the multicooker to show that the lid is locked and cannot be removed.	
2	<b>Status icons</b>		Shows if sounds are <b>On</b> or <b>Off</b> , as indicated.
			Indicates if the temperature scale is showing in Fahrenheit (°F) or Celsius (°C). See <b>Control panel: Settings</b> for details.
			Delay Start or cooking timer is running.
			Appears when Keep Warm is running, or is set to turn on after cooking finishes.
3	<b>WiFi indicator</b>	Lights up when paired with the Instant Brands Connect App and connected to a device. See <b>WiFi</b> for more information.	

*Illustrations in this document are for reference only and may differ from the actual product. Always refer to the actual product.*

# Control panel

4	Smart Programmes	<ul style="list-style-type: none"> <li>• Pressure Cook</li> <li>• Rice</li> <li>• Canning</li> <li>• Sauté</li> </ul>	<ul style="list-style-type: none"> <li>• Slow Cook</li> <li>• Steam</li> <li>• Yogurt</li> <li>• Sous Vide</li> </ul>
		See <b>Cooking</b> for details.	
5	Cooking progress bar	Shows when the multicooker is in <b>Pre-heating</b> , <b>Cooking</b> and <b>Keep Warm</b> modes. See <b>Control panel: Cooking progress bar</b> for more information.	
6	Time display	In standby, shows <b>OFF</b> . In a Smart Programme, counts up or down, depending on the programme.  Some Smart Programmes display the temperature in °C (Celsius) or °F (Fahrenheit).	
7	Pressure	Choose between <b>Low</b> , <b>High</b> and <b>Max</b> .	
8	Temperature	Choose between <b>Low</b> , <b>High</b> and <b>Custom</b> .	
9	Venting	Choose between 3 venting methods:	
			<b>Natural</b> release
			<b>Pulse</b> release
			<b>Quick</b> release
10	NutriBoost	Toggles the NutriBoost setting <b>On</b> and <b>Off</b> . See <b>Cooking: NutriBoost</b> for more information.	
11	Control dial	Turn the dial to adjust the time and temperature.	
12	Delay Start	Delay the start of cooking. Doubles as a kitchen timer!	
13	Keep Warm	Turns <b>Keep Warm</b> on or off.  Can only be used with Pressure Cook, Rice, Canning and Slow Cook, or as a standalone programme when in standby.	
14	Cancel	Stops a Smart Programme at any time and returns the multicooker to standby.	
15	Start	Begins the selected Smart Programme.	

# Control panel

## Cooking progress bar

**Pre-heating** is in progress. The display shows **On** during the pre-heating stage to let you know that it's working on getting up to temperature.



**Cooking** is shown after the Pro Plus reaches the target pressure or temperature required by the Smart Programme.



**Keep Warm** comes on automatically (unless you've turned it off) after cooking finishes to keep your meal at serving temperatures.

Only applies to Pressure Cook, Rice, Slow Cook and Canning.



## Status messages

OFF	The Pro Plus is in standby mode, ready whenever you are.
On	The multicooker is <b>Pre-heating</b> .
Hot	The cooking pot has reached the perfect cooking temperature and food can be added.  Only applies to Sauté and Sous Vide.
Hot	Display shows one of the following: <ul style="list-style-type: none"><li>• The remaining <b>Cooking</b> time when a Smart Programme is running,</li><li>• The <b>Delay Start</b> countdown,</li><li>• How long food has been in <b>Keep Warm</b>,</li></ul>
End	When cooking finishes, the display shows <b>End</b> until you remove the lid or touch <b>Cancel</b> .

Do you see something else? See **Troubleshooting** for more information.

# Settings

Setting	Description				
Turn sound on or off.	When in standby, touch and hold the sound icon for 2 seconds to toggle sounds on and off.  Audible safety and error message alerts cannot be turned off.				
Change displayed temperature (°C and °F).	When in standby, touch and hold the <b>thermometer icon</b> for 2 seconds to toggle between displaying °C and °F.				
Adjust and save custom cooking times and temperatures.	Once a Smart Programme is selected, changes to the cooking time, temperature and pressure level are saved once the Smart Programme begins.				
Delay the start of cooking.	<table border="1"> <thead> <tr> <th>Default time</th> <th>Time range</th> </tr> </thead> <tbody> <tr> <td>6 hours (06:00)</td> <td>10 minutes to 24 hours (00:10 to 24:00)</td> </tr> </tbody> </table>	Default time	Time range	6 hours (06:00)	10 minutes to 24 hours (00:10 to 24:00)
	Default time	Time range			
6 hours (06:00)	10 minutes to 24 hours (00:10 to 24:00)				
<ol style="list-style-type: none"> <li>Select and set up an applicable Smart Programme.</li> <li>When you're ready, touch <b>Delay Start</b>. The <b>hours field</b> flashes.</li> <li>Turn the dial to adjust the <b>hours field</b> as needed.</li> <li>Touch the <b>minutes field</b> to toggle to it. Turn the dial to adjust the <b>minutes field</b> as needed.</li> <li>Press <b>Start</b> to begin the delay countdown.</li> </ol> <p>Delay Start cannot be used with Sauté, Yogurt or Sous Vide.</p>					
Reset an individual Smart Programme.	When in standby, touch and hold the Smart Programme button you want to reset for 3 seconds. The Smart Programme's cooking time, pressure level and temperature are restored to the factory default setting.				
Reset all Smart Programmes.	When in standby, touch and hold <b>Cancel</b> until the multicooker beeps. All Smart Programme cooking times, pressure levels and temperatures are restored to factory default settings.				

# Pressure cooking

Pressure cooking uses pressure to raise the boiling point of water above 100°C. These high temperatures allow you to cook food much faster than normal.

When pressure cooking, the Instant Pot Pro Plus goes through 3 stages.

## How pressurising works

### Pre-heating

What you see	What you don't see	Tips
The cooking progress bar shows <b>Pre-heating</b> . The display shows <b>On</b> .	While the multicooker pre-heats, it vaporises liquid to create steam. Once enough steam has built up, the float valve pops up and locks the lid in place.	The time it takes the multicooker to pressurise depends on things like food and liquid temperature and volume. Frozen foods have the longest pre-heating time. For the fastest results, thaw your food before cooking it.

### Cooking

What you see	What you don't see	Tips
The cooking progress bar moves over to <b>Cooking</b> . The display switches to the cooking countdown timer.	When the Instant Pot reaches the required pressure level, cooking begins. The Instant Pot Pro Plus automatically maintains at <b>Low</b> , <b>High</b> or <b>Max</b> pressure throughout cooking.	A higher pressure means higher temperature. Smart Programme settings (e.g., cooking time, pressure level, etc.) can be adjusted at any time during cooking.

### Depressurisation

What you see	What you don't see	Tips
If Keep Warm is on after cooking, the cooking progress bar moves over to <b>Keep Warm</b> , and the timer counts up from <b>00:00</b> . If not, the multicooker begins venting and the venting icon flashes until finished.	Although food has finished cooking, the multicooker is still pressurised and hot.	Follow your recipe instructions when choosing a venting method. Venting releases pressure, lowers the temperature and allows you to safely remove the lid. See <b>Releasing pressure: Venting methods</b> on the next page for information on safe venting techniques.

# Releasing pressure

You **must** release pressure after pressure cooking before attempting to open the lid. Follow your recipe's instructions to choose a venting method.

## ⚠ WARNING

Steam ejected from the steam release valve is hot. **DO NOT** place hands, face, or any exposed skin over the steam release assembly when releasing pressure to avoid personal injury.

**DO NOT** cover or obstruct the steam release valve or cover to avoid personal injury and/or property damage.

## ⚠ DANGER

**DO NOT** attempt to remove the lid while the pressure indicator is on and **NEVER** attempt to force the lid open. Contents are under extreme pressure. Float valve must be down before attempting to remove the lid. Failure to follow these instructions may result in serious personal injury and/or property damage.

## Venting methods

### Natural release (NR or NPR)

After the cooking finishes, the temperature within the multicooker drops gradually and the multicooker depressurises naturally over time.

#### What to do

Touch the **Venting field** on the control panel to toggle to **Natural**.

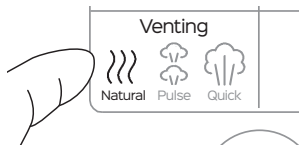

#### What to expect

When cooking finishes, the multicooker does not vent, so your meal continues to cook even after the Smart Programme ends.



Instant Tip: This is called "carryover cooking" or "resting", and it's great for large cuts of meat.

The depressurisation time may vary based upon the volume, type and temperature of food and liquid. It can take up to 40 minutes with some dishes, so plan ahead – it's well worth the wait!

When pressure is fully released, the Pressure indicator light turns off. Then it is safe to open the lid.

## NOTICE

Use NR to depressurise the multicooker after cooking high-starch foods (e.g., soups, stews, chilis, pasta, oatmeal and congee) or after cooking foods that expand when cooked (e.g., beans and grains).

# Releasing pressure

## Quick Release (QR or QPR)

When cooking finishes, a quick release drops the pressure and temperature quickly to prevent overcooking. Perfect for quick-cooking vegetables and delicate seafood!

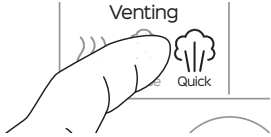
What to do	What to expect
<p>Touch the <b>Venting field</b> on the control panel to toggle to <b>Quick</b>.</p>  <p>The diagram shows a hand reaching towards a control panel. The panel has two buttons: 'Venting' on the left and 'Quick' on the right. The hand is positioned to touch the 'Venting' button, which is currently selected. The 'Quick' button is also visible.</p>	<p>When cooking finishes, the Pro Plus releases a warning puff and beeps 3 times, followed by a steady stream of steam from the top of the steam release valve.</p> <p><b>This is normal!</b></p> <p>When pressure is fully released, the Pressure indicator light turns off. Then it is safe to open the lid.</p>

## NOTICE

**DO NOT** use QR when cooking fatty, oily, thick or high-starch foods (e.g., stews, chilis, pasta and congee) or when cooking foods that expand when cooked (e.g., beans and grains).

If you see a lot of spatter while releasing pressure, touch the **Venting field** to return to **Natural**, then touch **Start**. Wait a few minutes before trying to release pressure again. If spatter continues, use NR to safely release the remaining pressure.

## Pulse release

When cooking completes, the Pro Plus releases timed bursts of steam to release pressure – perfect for rice, grains, and much more.

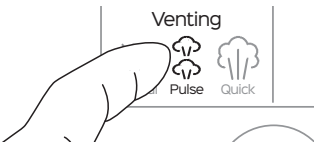
What to do	What to expect
<p>Touch the <b>Venting field</b> on the control panel to toggle to <b>Pulse</b>.</p>  <p>The diagram shows a hand reaching towards a control panel. The panel has two buttons: 'Venting' on the left and 'Pulse' on the right. The hand is positioned to touch the 'Venting' button, which is currently selected. The 'Pulse' button is also visible.</p>	<p>When cooking finishes, the multicooker releases a short burst of steam every 15 seconds.</p> <p>When pressure is fully released, the Pressure indicator light turns off. Then it is safe to open the lid.</p>

# Pressure control features

See **Care, cleaning and storage** for installation and removal of parts.

## Pressure cooking lid

When it's plugged in, the Pro Plus plays a little jingle when you open and close the lid.

What we love about it	What you should know about it
<p>When you close the lid, it automatically gets ready to seal for <i>seriously easy</i> pressure cooking.</p> <p>It closes over the handles on the cooking pot.</p> <p>The lid handle is comfortable to use whether you're left or right-handed, and, stands up in the multicooker base!</p>	<p>The lid is removable during non-pressure cooking so you can taste-test as you go.</p> <p>When pressure cooking, the lid only locks into place once the multicooker has pressurised.</p> <p>Try not to remove the lid unnecessarily.</p>

### Removing the lid

- 01** Grip the handle and turn it counter-clockwise to align the ▼ on the lid with the █ on the rim of the multicooker base.

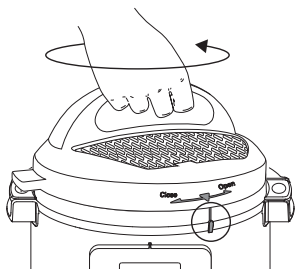

- 02** Lift the lid up and off the multicooker base towards your body.

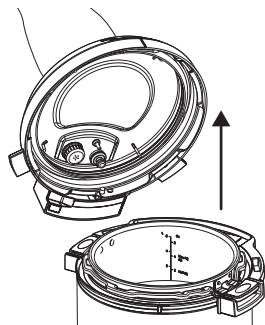

### Closing the lid

- 01** Align the ▼ on the lid with the █ on the multicooker base, then lower the lid onto the track.

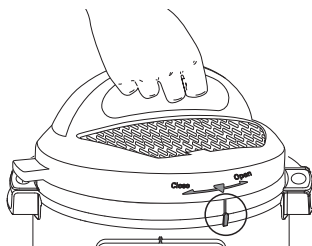

- 02** Turn the lid clockwise until the ▼ on the lid aligns with the middle of the control panel.

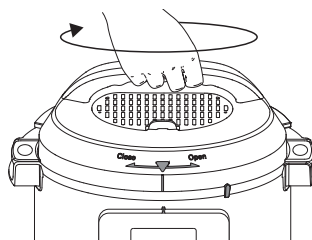

See **Releasing pressure** for safe depressurisation techniques.

# Pressure control features

## QuickCool

For the fastest Natural release after pressure cooking, use the QuickCool tray\*.

What we love about it	What you should know about it
It's a huge timer saver – you can release pressure naturally up to 50% faster!	The metal portion of the lid gets <b>extremely hot</b> , so don't remove the protective cover unless you're using QuickCool.

To use the QuickCool tray, fill it with ice or water and freeze it. Once frozen, position the QuickCool tray on the exposed metal of the lid.

When the float valve drops into the lid, remove the QuickCool tray, discard the water, and open the lid.

\*QuickCool tray sold separately at [instantbrands.co.uk](https://instantbrands.co.uk).

### CAUTION

The lid will be hot during and after cooking. **DO NOT** touch the exposed metal with bare skin to avoid burn injury.

### CAUTION

The QuickCool tray is not intended to serve food or liquid. To avoid risk of personal injury, do not consume food or liquid from the QuickCool tray.

# Pressure control features

## Steam release assembly

The steam release assembly must be fully installed before use.

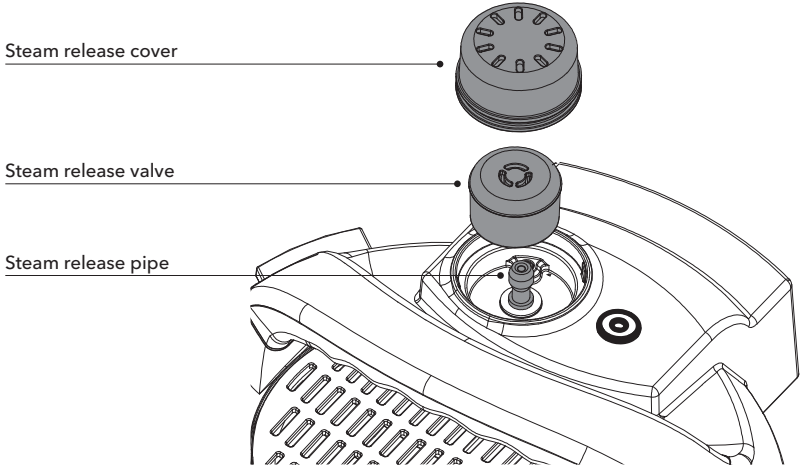

### What we love about it

The steam release cover disperses the steam, so the pressure releases gently.

### What you should know about it

The steam release valve sits loosely on the steam release pipe.

When releasing pressure, steam travels up from the cooking pot, through the steam release pipe and steam release valve, and out the top of the steam release cover. It's important to keep the area clean and clear.

### **⚠ WARNING**

Do not cover or block the steam release assembly in any way to avoid personal injury and/or property damage.

# Pressure control features

## Anti-block shield

The anti-block shield prevents food particles from coming up through the steam release pipe, which assists with pressure regulation.

The anti-block shield is integral to product safety and necessary for pressure cooking, so it must be installed before use.

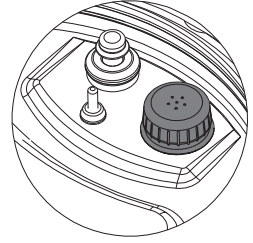



## Sealing ring

When the pressure cooking lid is closed, the sealing ring creates an air-tight seal between the lid and the cooking pot.

The sealing ring must be installed before use.

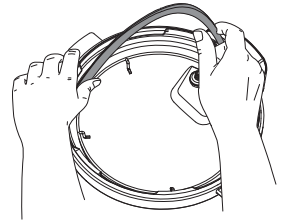
 Only one sealing ring should be installed in the lid at a time.



 **Instant Tip:** Silicone is porous, so it absorbs strong aromas and certain flavours. Keep extra sealing rings on hand to limit the transfer of those aromas and flavours between dishes. Visit our store to start colour coding your cooking!

## CAUTION

Always check for cuts, deformation and correct installation before cooking, as sealing rings stretch over time with normal use. If you notice stretching, deformation, or damage to your sealing ring, **DO NOT** use it.

Replace the sealing ring every 12 to 18 months or sooner, and only use authorised Instant Pot sealing rings.

Failure to follow these instructions may cause food to discharge, which may lead to personal injury or property damage.

# Pressure control features

## Pressure indicator

The pressure indicator on the control panel indicates when the lid is safe to open.

- **Pressurised**  
The pressure indicator icon will highlight in red indicating it is not safe to open the lid.
- **Depressurised**  
When the pressure indicator icon is not lit the unit is safe to open.

The float valve and silicone cap work together to seal in pressurised steam. Do not attempt to operate the Instant Pot without the float valve properly installed.



### **DANGER**

**DO NOT attempt to remove the lid while the pressure indicator is lit and NEVER attempt to force the lid open.** Contents are under extreme pressure. Float valve must be down before attempting to remove the lid. Failure to follow these instructions may result in serious personal injury and/or property damage.

# Cooking

The Instant Pot Pro Plus is amazingly versatile in the kitchen.

If you need to make changes to the cooking time, pressure level, venting or temperature after a programme has started, just touch the related field, customise the Smart Programme as you like, then touch **Start!**

## CAUTION

Always inspect the lid and cooking pot carefully to make sure they are clean and in good working condition before use.

- To avoid personal injury or damage to the appliance, replace the cooking pot if it is dented, deformed, or damaged.
- Use only authorised Instant Pot cooking pots made for this model when cooking.

Always make sure the heating element is clean and dry before inserting the cooking pot into the multicooker base.

Failure to follow these instructions may damage the multicooker. Replace damaged parts to make sure safe function.

## WARNING

DO NOT fill cooking pot higher than the **Max PC Fill** line as indicated on the cooking pot.

When cooking foods that expand (e.g., rice, beans, pasta) do not fill the cooking pot higher than the **Half Fill** line as indicated on the cooking pot.

Always cook with the cooking pot in place. DO NOT pour food or liquid into the multicooker base.

To avoid risk of personal injury and/or property damage, place food and liquid ingredients in the cooking pot, then insert the cooking pot into the multicooker base.

## CAUTION

When cooking meat, always use a meat thermometer to ensure the internal temperature reaches a safe minimum temperature.

# Cooking

## Pressure Cook, Rice and Canning

Jump start magic! These programmes use pressurised steam to cook food quickly, evenly, and deeply, for delicious results every time!

For the best pressure cooking results, always follow an authorised Instant Pot recipe or our tried, tested and true pressure cooking timetables which feature grain-to-water ratios for making a variety of rice and grains.

Choose from 3 pressure levels, depending on the Smart Programme.

Pressure level	Suggested use	Notes
<b>Low</b> 5.8 - 7.2 psi (30 - 50 kPa)	Fish and seafood, soft vegetables and rice. Also for canning of high-acid foods.	When pressure cooking, the pressure level controls the cooking temperature, so a higher pressure results in a higher cooking temperature.
<b>High</b> 10.2 - 11.6 psi (70 - 90 kPa)	Eggs, meat, poultry, root vegetables, oats, beans, grains, bone broth, stew, chili.	
<b>Max</b> (15 psi) (95 - 115 kPa)	Canning of low-acid foods, tough cuts of meat and for flavourful broths.	

Pressure cooking liquids should be water-based, such as broth, stock, soup or juice. If using canned, condensed or cream-based soup, add liquid as directed below.

Instant Pot size	Minimum liquid for pressure cooking*
<b>5.7 Litres</b>	375 mL

\*Unless otherwise specified in recipe.

 Instant Tip: Use the multi-functional rack to heat food evenly, prevent nutrients from leeching into the cooking liquid, allow oil and grease to drip off the food, and, prevent food from scorching the bottom of the cooking pot.

### CAUTION

To avoid scorching or scalding injury, be cautious when pressure cooking with more than 60 mL of oil, oil-based sauces, condensed cream-based soups, and thick sauces. Add suitable liquid to thin sauces. Avoid recipes that call for more than 1/4 cup 60 mL of oil or fat content.

# Cooking

## Pressure Cook, Rice and Canning

Smart programme	Default cooking time	Cooking time range	Default pressure	Pressure levels available
<b>Pressure Cook</b>	10 minutes (00:10)	0 minutes to 4 hours (00:00 to 04:00)	High	Low High Max
<b>Rice</b>	12 minutes (00:12)	0 minutes to 1 hour (00:00 to 01:00)	Low	Low High
<b>Canning</b>	30 minutes (00:30)	0 minutes to 4 hours (00:00 to 04:00)	Max	Low Max

- 01** Add food and liquid to the cooking pot as indicated in your recipe.
  - 02** Insert the cooking pot into the multicooker base.
  - 03** Place and close the pressure cooking lid as described in **Pressure control features: Pressure cooking lid**.
  - 04** Touch the Smart Programme you want to use: **Pressure Cook, Rice** or **Canning**.
  - 05** Touch the **hours field** or the **minutes field**, then turn the dial to adjust the cooking time in hours and/or minutes.
  - 06** Touch the **Pressure field** to toggle between available **Low, High** and **Max** pressure levels.
  - 07** Touch the **Venting field** to toggle between **Natural, Pulse** and **Quick** release options.
  - 08** Touch **Start** to begin.
-  The display shows **On** and the cooking progress bar shows Pre-heating.
- Read **Pressure Cooking 101** to get a glimpse behind the curtain and find out what's going on in that big ol' magic pot.
- 09** When the Smart Programme finishes the display shows **End** if Keep Warm is turned off. If not, the timer begins counting from **00:00** up to 10 hours (**10:00**).

Keep Warm comes on automatically. If you don't want the Pro Plus to Keep Warm after cooking, press **Keep Warm** to turn it off any time.

A delay start timer can be set to automatically start pressure cooking. To set a delay start timer, see **Control panel: Settings**.

# About Canning

The Canning Smart Programme is a pressure cooking function based on traditional canning principles. Following proper canning processes, canning can be an easy, economical way to preserve quality food at home.

The Pro Plus uses 2 pressure canning settings:

<b>Low</b>	Perfect for canning high-acid fruit, including sauces, jams and chutneys.
<b>Max</b>	Store your amazing vegetarian sauces and high-acid vegetables, as well as low-acid foods such as sauces and soups containing meat.

## ⚠ CAUTION

Recipes must be closely followed when canning. Modifying cooking times, ingredients or temperatures can be dangerous. Use the exact time, temperature/pressure and method specified in the recipe to protect the food from harmful bacteria, molds and enzymes.

Improper canning may cause preserves to spoil, which may result in illness. Do not pressure can at altitudes above 2000m (6600ft).

## Sterilising jars for canning

Your preserves must be placed into sterile, empty jars.

## NOTICE

Always check your jars, lids, and seals for chips and other imperfections. Sterilization of jars should occur just before filling. Excess contact with the air should be avoided for safe canning.

- 01** Wash the jars with hot water and dish soap, then rinse them thoroughly.
- 02** Place the cooking pot into the cooker base, then lay the steam rack on the bottom of the cooking pot.
- 03** Place the jars on the steam rack. The pressure cooker will hold up to 4 x 500 mL jars.
- 04** Fill the cooking pot to the first line (1) with water.
- 05** Follow steps **03** to **07** in **Pressure Cook, Rice** and **Canning** to programme the following:
  - Pressure level: **Low**
  - Time: 10 minutes (**00:10**)
  - Venting method: **Quick**
- 06** Touch **Start** to begin sterilisation.

# Canning 101

## Filling jars for canning

Choose a recipe that has been pre-tested and approved for pressure canning. Though ingredients may vary, the process will be the same!

**01** Fill warm, sterilised canning jars with food and liquid.

Follow your recipe to allow for the required headspace.

**02** Use a sterilised, flexible, nonporous spatula, to remove trapped air bubbles.

**03** Place a sterilised lid on top of the jar, then add a screw band. Hand-tighten the band. **Do not over-tighten.**

Place the filled and sealed jars on the steam rack in the cooking pot.

**04** Pour hot water into the cooking pot until the jars are  $\frac{1}{4}$  of the way immersed  $1\frac{1}{2}$  L.

**05** Follow the steps in **Cooking: Pressure Cook, Rice and Canning** (starting at step 02) to set the appropriate canning time and pressure levels for your recipe.

# Cooking

## NutriBoost™

NutriBoost is a mid-cooking Pulse release setting that can be activated during the Pressure Cook and Rice Smart Programmes. The boiling motion effect helps to break down food, which adds nutrients, enhances flavours, and improves textures. Amazing for rich bone broth and creamy risotto!

NutriBoost is super easy to use – just touch the **NutriBoost field** to turn it **On** and **Off**, as you like.

Smart Programme	What you should know about it
Pressure Cook	The multicooker will release puffs of steam during the last 15 minutes of the <b>Cooking</b> stage.
Rice	The multicooker will release puffs of steam during the first 3 minutes of the <b>Cooking</b> stage.

### CAUTION

To avoid spatter and food ejection, do not use NutriBoost when cooking starchy or foamy food like porridge, oatmeal or pasta. The multicooker should be closely monitored when using NutriBoost.

# Cooking

## Steam

The Steam programme works like a regular stovetop steamer, boiling liquid in the cooking pot to cook food with hot steam. When steaming, use the multi-functional rack to keep food out of the boiling liquid.

Smart Programme	Default time	Time range	Default temperature
Steam	10 minutes (00:10)	1 minute to 1 hour (00:01 to 01:00)	98°C Not adjustable.

### CAUTION

The cooking pot and accessories will be hot during and after cooking. Always use appropriate hand protection when adding to or removing food from a hot cooking pot to avoid personal injury and/or property damage.

### NOTICE

The lid is removable throughout the cooking process for easy access. The product keeps releasing steam under steam mode to avoid pressure building inside the cooking pot.

### NOTICE

If there is steam in the cooking pot, you may notice some resistance when replacing the lid. Allow the lid to settle into the track completely before closing it.

- 01 Add water to the cooking pot.
- 02 Insert the cooking pot into the multicooker base.
- 03 Place and close the pressure cooking lid as described in **Pressure control features: Pressure cooking lid**.
- 04 Touch **Steam**.
- 05 Turn the dial to adjust the cooking time.
- 06 Press **Start** to begin.  
The display shows **On** and the cooking progress bar shows **Pre-heating**.
- 07 When the Pro Plus reaches the target temperature, the progress bar moves over to **Cooking** and the timer counts down.
- 08 When the Smart Programme finishes the display shows **End**.

Automatic Keep Warm cannot be used with Steam.

A delay start timer can be set to automatically start steaming while you're in bed, working, running errands or busy with other dishes. To set a delay start timer, see **Control panel: Settings**.

# Cooking

## Slow Cook

The Slow Cook programme is comparable to a traditional slow cooker, so you can keep using all your favourite family recipes!

Cooking time range	Temperature level	Suggested use	Notes
30 minutes to 24 hours (00:30 to 24:00)	Low	For that low and slow, all-day kind of cooking.	You can use the pressure cooking lid, or, if you want to watch your food while it cooks, any glass lid with a venting hole will do.
	High	Slow cooking, but a little bit faster.	Dishes should cook for at least 3 hours (03:00) unless otherwise stated in your recipe.

The lid is removable throughout the cooking process for easy access. The product keeps releasing steam under slow cook mode to avoid pressure building inside the cooking pot. See **Releasing pressure** for safe venting techniques.

- 01** Add food and liquid ingredients to the cooking pot according to your recipe.
- 02** Insert the cooking pot into the multicooker base.
- 03** Place and close the pressure cooking lid as described in **Pressure control features: Pressure cooking lid**.
- 04** Touch **Slow Cook**.
- 05** Touch the **hours field** or the **minutes field**, then turn the dial to adjust the cooking time in hours and/or minutes.
- 06** Touch the **Temperature field** to toggle between **High** and **Low** temperatures.
- 07** Press **Start** to begin.  
The progress bar shows **Pre-heating** and the timer starts counting down immediately.
- 08** When the Pro Plus reaches the target temperature the progress bar moves over to **Cooking**.
- 09** When the Smart Programme finishes the display shows **End** if Keep Warm is turned off. If not, the timer begins counting from **00:00** up to 10 hours (**10:00**).

Keep Warm feature comes on automatically after Slow Cook finishes. If you don't want the Pro Plus to Keep Warm automatically, press **Keep Warm** to turn it off any time.

A delay start timer can be set to automatically start slow cooking while you're in bed, working, running errands or busy with other dishes. To set a delay start timer, see **Control panel: Settings**.

# Cooking

## Sauté

Like using a frying pan, griddle or flat-top grill, use Sauté to simmer, reduce and thicken liquids, stir-fry meals and to caramelize vegetables and sear meat before or after using other cooking methods.

 Instant Tip: If you prefer, you can use the cooking pot on any electric, ceramic, gas and induction cooktop. The silicone-grip handles make it easy to hold on to and stir without slipping!

Default time	Time range	Default temperature	Temperature range
30 minutes (00:30)	1 minute to 1 hour (00:01 to 01:00)	High	High Low Custom: Levels 1 to 6

- 01 Insert the cooking pot into the multicooker base. **Do not use a lid.**
- 02 Touch **Sauté**.
- 03 Turn the dial to adjust the cooking time.
- 04 Touch the **Temperature field** to toggle between **Low**, **High** and **Custom** temperatures. To set a custom temperature, turn the dial to select your preferred temperature level. There are 6 levels of custom temperatures to choose from, shown as **LE 1** (the lowest temperature) through **LE 6** (the highest temperature). These levels are similar to the temperature levels on your stovetop.
- 05 Touch **Start** to begin.  
The display shows **On** and the cooking progress bar shows **Pre-heating**.
- 06 When the Pro Plus reaches the target temperature the progress bar moves over to **Cooking** and the display shows **Hot** for a few moments before switching over to the countdown timer.
- 07 Add ingredients to the cooking pot.  
 If your food ingredients are added before the cooking pot has reached the target temperature, the Hot message may not appear. This is normal.
- 08 If the ingredients finish cooking before the time runs out, touch **Cancel** to end the Smart Programme, otherwise, when the Smart Programme finishes the display shows **End**.

Delay Start and automatic Keep Warm cannot be used with Sauté.

# Cooking

## Deglazing

Sautéing meat and vegetables before pressure cooking is the perfect way to boost flavours, as sugars caramelize from the high heat of the Sauté Smart Programme. Deglazing the cooking pot lets you unlock those flavours in amazing sauces, gravy and more.

To deglaze, remove food items from the cooking pot and add a thin liquid, like water, broth or wine to the hot surface. Use a wooden or silicone scraper to lift up any food stuck to the bottom of the cooking pot and stir it into the liquid.

### CAUTION

The Sauté Smart Programme reaches high temperatures. If left unmonitored, food may burn on this setting. **DO NOT** use a lid and **DO NOT** leave the multicooker unattended while using Sauté.

## Yogurt

Made for easy fermenting dairy and non-dairy yogurt recipes that you can make again and again.

Instant Pot size	Minimum milk volume	Maximum milk volume
5.7 Litres	1 L	3.8 L

Temperature level	Temperature range	Default time	Time range	Suggested use
Low	Not adjustable	8 hours (08:00)	30 minutes to 99 hours and 30 minutes (00:30 to 99:30)	Fermentation
High	Not adjustable	<b>boiL</b>	Not adjustable	Pasteurisation
Custom Default: 33°C	25 to 85°C	8 hours (08:00)	30 minutes to 99 hours and 30 minutes (00:30 to 99:30)	Non-dairy fermentation

# Cooking

Starting with...	Do this!
Pasteurised or unpasteurised milk	Follow all the steps below
Ultra-pasteurised milk	Skip to <b>Step 2: Add starter culture</b> . This is the “cold start” method of yogurt making.

## What You'll Need:

- Food Thermometer
- Milk or a non-dairy alternative
- Active yogurt culture

## Step 1: Pasteurise milk

**01** Add milk or milk alternative to the cooking pot, and any other ingredients that your recipe calls for.

**02** Place and close the pressure cooking lid as described in **Pressure control features: Pressure cooking lid**.

**03** Touch **Yogurt**.

**04** Touch the **Temperature field** to toggle to **High**.

 The pasteurisation time and temperature are preset and cannot be adjusted.

**05** Press **Start** to begin.

The display shows **On** and the progress bar shows **Pre-heating**. **Boil** will display as the progress bar switches to cooking.

**06** The display shows **End** when pasteurisation is complete.

 Milk must reach a minimum of 72°C to pasteurise properly. Use a thermometer to check the temperature.

## Step 2: Add starter culture

**01** Using a thermometer, allow the milk to cool to just below 43°C.

**02** Add your starter culture to the milk according to the instructions included with the starter culture product.

 Plain yogurt with active cultures can be used as a starter. Follow a trusted Instant Pot yogurt recipe when using yogurt as a starter culture.

**03** Place and close the pressure cooking lid as described in **Pressure control features: Pressure cooking lid**.

## Step 3: Ferment milk

**01** Touch **Yogurt**.

**02** Touch the **Temperature field** to toggle to **Low**.

To set a custom temperature, touch the **Temperature field** to toggle to **Cus**, then turn the dial to select a temperature.

**03** Touch the **hours field** or the **minutes field**, then turn the dial to adjust the fermentation time in hours and/or minutes.

**04** Touch **Start** to begin. The display shows **On** and the progress bar shows **Pre-heating**.

**05** The display shows **End** when fermentation is complete.

# Cooking

## Tips for yogurt making

- The thicker the milk, the thicker the yogurt!
- For even thicker yogurt, pasteurise your milk twice before fermenting.
- The longer you ferment your milk, the tangier the yogurt will be.
- Use a cheesecloth to strain out liquid whey to get rich Greek-style yogurt.
- Cool your fresh yogurt, then put it in the fridge (covered) for 12 to 24 hours to allow the flavours to develop.
- Honey, nuts, seeds and fresh fruit are perfect toppers for your homemade yogurt!

## Using yogurt cups

Yogurt cups are a convenient way to portion out yogurt servings.

- 01** After **Step 2: Add started culture**, carefully pour the milk into your yogurt cups and seal them tightly.
- 02** Place the steam rack on the bottom of the cooking pot.
- 03** Position the yogurt cups on the rack and add water to the cooking pot until the cups are immersed halfway.
- 04** Follow the steps in **Step 3: Ferment yogurt** normally.

# Cooking

## Sous Vide

Sous Vide cooking involves cooking food underwater, in an air-tight, food-safe bag, for a long period of time. Food cooks in its own juices and comes out delicious and unbelievably tender.

### CAUTION

Do not overfill the cooking pot to avoid damage to the multicooker. Total contents (water and food pouches) should leave at least 5 cm of headspace between the water line and the brim of the cooking pot.

Default cooking time	Time range	Default temperature	Temperature range
3 hours (03:00)	30 minutes to 99 hours and 30 minutes (00:30 to 99:30)	56°C	25 to 90°C

### You'll need:

- Tongs
- Thermometer
- Food safe, airtight, re-sealable food pouches, or,
- Vacuum sealer and food-safe vacuum bags

### Step 1: Set up the sous vide water bath

**01** Fill the cooking pot to the **Half Fill** mark as indicated on your cooking pot, then insert it into the multicooker base.

**02** Place and close the pressure cooking lid as described in **Pressure control features: Pressure cooking lid**.

### Step 2: Setting up the Pro Plus for sous vide cooking

**03** Touch **Sous Vide**.

**04** Touch the **hours field** or the **minutes field**, then turn the dial to adjust the cooking time in hours and/or minutes.

**05** To set a custom temperature, touch the **Temperature field** then turn the dial to adjust the water bath temperature.

**06** Press **Start** to begin heating the water in the cooking pot.

The display shows **On** and the progress bar shows Pre-heating.

### Step 3: Get food ready

**01** While the water heats, start by seasoning your food as desired. See **Ingredients and seasonings** below for tips!

**02** When you're ready, separate each serving of food into individual pouches.

**03** Remove all air from the pouches and seal them tightly.

# Cooking

## Step 4: Cook 'em up!

**01** Once the water bath is ready, the display shows **Hot** for a few moments before switching over to the countdown timer.

**02** Remove the lid and carefully immerse the sealed pouches.

 The food in the pouches should be immersed, so add heated water to the cooking pot any time it's needed, but, if you're using a re-sealable bag, make sure the seal stays above the water.

**03** Place and close the pressure cooking lid as described in **Pressure control features: Pressure cooking lid**.

**04** When the Smart Programme finishes the display shows **End**. Open the multicooker and use your tongs to carefully remove the pouches from the hot water.

**05** Open the pouches and use a thermometer to check for readiness.

## Reverse Searing

Searing your meat after low and slow cooking is the easiest way to boost those already-delicious flavours through the roof without overcooking. Try reverse searing for tender, juicy meat with a beautiful crust.

**01** After Sous Vide cooking, remove the meat from the cooking pouch and gently pat it dry to remove as much moisture from the exterior of the meat.

 It may seem counterintuitive, but don't skip this step – you'll end up with more flavour and a great-looking finish!

**02** Use the Sauté programme to give it a good sear, or use a cast iron pan, browning torch, or a grill – anything hot to lock in that moisture!

**03** Cover your meat with foil and let it rest for 5-20 minutes, depending on the size of the cut.

## Ingredients and Seasonings

- Salt goes a long way when it has nowhere to go, so it's better to use a little less than you normally would, especially with meats, poultry, and fish. If you find it needs more after cooking, it's easy to salt to taste.
- Use high quality, fresh ingredients when cooking sous vide to ensure the best possible flavour.
- Use fresh garlic instead of garlic powder. Garlic powder can turn bitter when cooked sous vide. Fresh garlic will give you the best results.

# Cooking

## Keep Warm

Perfect to reheat meals or warm food for long periods of time.

Default time	Time range	Default temperature	Temperature range
10 hours (10:00)	10 minutes to 10 hours (00:10 to 10:00)	High	High Low Custom: 25 to 90°C

- 01** Touch **Keep Warm**.
- 02** Touch the **hours field** or the **minutes field**, then turn the dial to adjust the warming time in hours and/or minutes.
- 03** Touch the **Temperature field** to toggle between **Low**, **High** and **Custom** temperature levels.  
  
To set a custom temperature, touch the **Temperature field** to toggle to **Cus**, then turn the dial to choose a temperature.
- 04** Touch **Start** to begin. The progress bar shows **Keep Warm** and the timer starts counting down immediately.
- 05** When Keep Warm completes, the display shows **End**.

### CAUTION

Thicker foods may prevent even heating, which can lead to spoiled food if left unattended. When cooking thick foods like stew and chili, stir the contents of the cooking pot every 40 to 60 minutes to make sure that heat is evenly distributed.

# Care, cleaning and storage

Clean your Instant Pot Pro Plus and its parts after each use. Failure to follow these cleaning instructions may result in catastrophic failure, which may lead to property damage and/or severe personal injury.

Always unplug your multicooker and let it cool to room temperature before cleaning. Never use metal scouring pads, abrasive powders or harsh chemical detergents on any of the Instant Pot's parts or accessories.

Let all surfaces dry thoroughly before use, and before storage.

Parts	Cleaning methods and instruction
<b>Accessories</b> <ul style="list-style-type: none"> <li>• Steam rack</li> </ul>	Dishwasher safe if placed on the top rack.
<b>Lid and parts</b> <ul style="list-style-type: none"> <li>• Steam release valve</li> <li>• Steam release cover</li> <li>• Anti-block shield</li> <li>• Sealing ring</li> <li>• QuickCool cover</li> <li>• Condensation collector</li> </ul>	Dishwasher safe if placed on the top rack. Remove all the parts from the lid before cleaning. See <b>Care, cleaning and storage: Removing and installing parts.</b> <ul style="list-style-type: none"> <li>• With the steam release valve and anti-block shield removed, clean the interior of the steam release pipe with a pipe cleaner to prevent clogging.</li> <li>• To drain water from the lid after dishwashing, grasp the lid handle and hold the lid vertically over a sink, then turn it 360°– like turning a steering wheel.</li> <li>• After cleaning and draining, store the lid upside down on the multicooker base to allow it to air dry completely.</li> <li>• Store sealing rings in a well-ventilated area to decrease residual odour of flavourful meals. To eliminate odours, add 250 mL water and 250 mL white vinegar to the cooking pot, then run Pressure Cook for 5 to 10 minutes and QR pressure.</li> <li>• Check the condensation collector after each use and empty and clean it as needed. Do not allow food or moisture to sit in the condensation collector, as harmful bacteria may result.</li> </ul>
<b>Cooking pot</b>	Dishwasher safe. <ul style="list-style-type: none"> <li>• Acute hard water staining (rainbow, bluish or white discoloration) may require scrubbing with a sponge dampened with vinegar or a nonabrasive cleanser.</li> <li>• For tough or burned food residue, add boiling water and dish soap to the cooking pot and let it sit for a few hours for easy cleaning.</li> <li>• Make sure all exterior surfaces are dry before placing the cooking pot in the multicooker base.</li> </ul>
<b>Power cord</b>	Wipe only. <ul style="list-style-type: none"> <li>• Use a barely damp cloth to remove particles from the cord.</li> <li>• Wrap it around the multicooker base and tuck the end into the cord holder.</li> </ul>
<b>Multicooker base</b>	Wipe only. <ul style="list-style-type: none"> <li>• Wipe the inside of the outer pot as well as the condensation rim with a barely damp cloth. Allow them to dry completely before inserting the cooking pot.</li> <li>• Clean the multicooker base and control panel with a soft, barely damp cloth or sponge.</li> </ul>

Some discolouration may occur after machine washing, but this will not affect the multicooker's safety or performance.

## Care, cleaning and storage

### WARNING

The multicooker base contains electrical components. To avoid fire, electric leakage and/or personal injury, make sure the multicooker base always stays dry.

- DO NOT immerse the multicooker base in water or other liquid or attempt to cycle it through the dishwasher.
- DO NOT rinse the heating element.
- DO NOT submerge or rinse the power cord or the plug.

# Care, cleaning and storage

## Removing and installing parts

### Silicone sealing ring

#### *Remove the sealing ring*

Grip the edge of the silicone and pull the sealing ring out from behind the circular stainless-steel sealing ring rack.

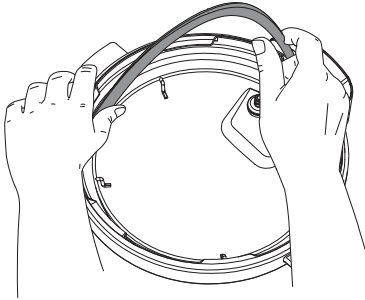

With the sealing ring removed, check the ring rack to make sure it is secured, centered, and an even height all the way around the lid. Do not attempt to repair a deformed ring rack.

 **Instant Tip:** The sealing ring is easiest to remove and install when it is wet and soapy.

#### *Install the sealing ring*

Place the sealing ring over the sealing ring rack and firmly press it into place. Make sure there's no puckering.

 It should be snug behind the sealing ring rack. It can wiggle a bit but shouldn't fall out when you turn over the lid.

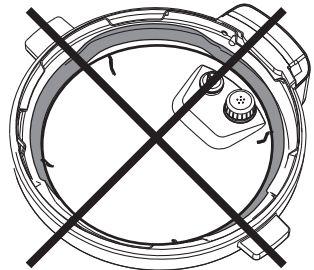
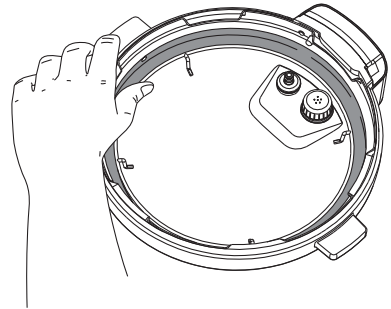

# Care, cleaning and storage

## Steam release assembly

### **Remove the steam release assembly**

Remove the steam release cover, then pull the steam release valve up and off the steam release pipe.

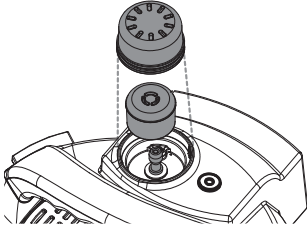

### **Install the steam release assembly**

Place the steam release valve on the steam release pipe and press down firmly.

 The steam release valve sits loosely on the steam release pipe but should remain in place when the lid is turned over.

Place the steam release cover over the steam release valve and press down. The cover is pressure-fit in place.

## Anti-block shield

### **Remove the anti-block shield**

Grip the lid like a steering wheel and use your thumbs to press firmly against the side of the anti-block shield (pressing towards the side of the lid and up) until it pops off the prongs underneath.

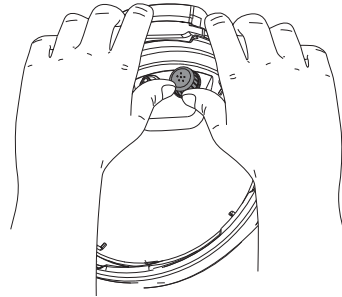

### **Install the anti-block shield**

Place anti-block shield over prongs and press down until it snaps into position.

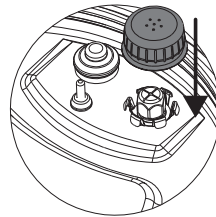

# Care, cleaning and storage

## Condensation collector

The condensation collector sits at the back of the multicooker base and catches any overflow from the condensation rim.

### **Remove the condensation collector**

Pull the condensation collector away from the multicooker base; **do not pull down**.

 The tabs on the multicooker base and the grooves on the condensation collector.

### **Install the condensation collector**

Align the grooves on the condensation collector over the tabs on the back of the multicooker base and slide the condensation collector into place like closing a drawer.

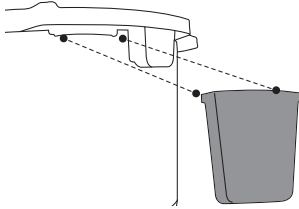

## QuickCool protective cover

### **Remove the protective cover**

Grip the tab and push it towards the lid handle, then pull it up, towards you, and off.

### **Install the protective cover**

Grip the tab and slide the cover towards the back of the metal portion of the lid, then press down until it clicks.

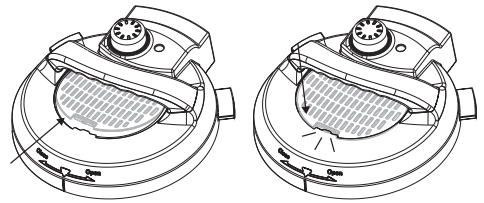

# Troubleshooting

**Register** your Instant Pot Pro Plus today!

If your issue persists or you have any additional questions, get in touch with a Customer Care Advisor by email at [UKSupport@instantbrands.com](mailto:UKSupport@instantbrands.com) (if located in the UK) or [EUSupport@instantbrands.com](mailto:EUSupport@instantbrands.com) (if located in the EU) or by phone at **+44 (0) 3331 230051**.

Problem	Possible reason	Try this
<b>Occasional clicking or light cracking sound.</b>	The sound of power switching, or the pressure board may be expanding due to changing temperatures.	This is normal; no action needed.
	Bottom of the cooking pot is wet.	Wipe exterior surfaces of the cooking pot. Make sure the heating element is dry before inserting the cooking pot into the multicooker base.
<b>Difficulty closing the lid.</b>	Sealing ring is not properly installed.	Reposition the sealing ring. Make sure it is snug behind the sealing ring rack.
	Float valve is in the popped-up position.	Gently press the float valve downward with a long utensil.
	Contents in multicooker are still hot.	Lower the lid onto the multicooker base slowly, allowing heat to dissipate.
<b>Difficulty opening the lid.</b>	<b>⚠ DANGER</b> Contents may be under pressure. To avoid scalding injury, DO NOT attempt to force the lid open.	
	Pressure inside the multicooker.	Release pressure according to recipe. Only open the lid after the pressure indicator is off.
	Float valve stuck due to food debris or residue around the float valve.	Make sure steam is completely released by quick releasing pressure. Open the lid cautiously, then thoroughly clean the float valve, surrounding area and lid before next use.
<b>The cooking pot is stuck to the lid when the multicooker is opened.</b>	Cooling of the cooking pot may create suction, causing the cooking pot to adhere to the lid.	Select quick release to release all the pressure from the cooking pot.

# Troubleshooting

Problem	Possible reason	Try this
<b>Steam leaks from the side of the lid.</b>	No sealing ring in the lid.	Install a sealing ring.
	The sealing ring is damaged or not installed properly.	Replace the sealing ring.
	Food debris on the sealing ring.	Remove the sealing ring and clean it thoroughly.
	The lid is not closed properly.	Open, then close the lid.
	The sealing ring rack is warped or off-center.	Remove the sealing ring from the lid, then check the sealing ring rack for bends or warps. Contact <b>Customer Care</b> .
	The cooking pot rim may be misshapen.	Check for deformation and contact <b>Customer Care</b> .
<b>Cooker can't build pressure.</b>	Food debris on the float valve or float valve silicone cap.	Run clear water through float valve in the lid. Perform the <b>Initial test run</b> to check for function and record your findings. Contact <b>Customer Care</b> .
	Too little liquid in the cooking pot.	Check for scorching on the bottom of the cooking pot. Add thin, water-based liquid to the cooking pot according to its size.
	Float valve silicone cap damaged or missing.	Contact <b>Customer Care</b> .
	Float valve obstructed by lid-locking mechanism.	Contact <b>Customer Care</b> .
	No heat in the cooking pot.	Perform the <b>Initial test run</b> to check for function and record your findings. Contact <b>Customer Care</b> .
	Cooking pot base may be damaged.	Perform the <b>Initial test run</b> to check for function and record your findings. Contact <b>Customer Care</b> .
<b>Minor steam leaking or hissing from the steam release valve during Cooking.</b>	The multicooker is regulating excess pressure.	This is normal; no action required.
<b>Steam gushes from the steam release valve during pressure cooking cycle.</b>	Not enough liquid in the cooking pot.	Add thin, water-based liquid to the cooking pot according to its size.
	Pressure sensor control failure.	Contact <b>Customer Care</b> .

# Troubleshooting

Problem	Possible reason		Try this
The display remains blank after connecting the power cord.	Bad power connection or no power.		Check outlet to make sure it is powered. Inspect power cord for damage. If you notice damage, contact <b>Customer Care</b> .
	The multicooker's electrical fuse has blown.		Contact <b>Customer Care</b> .
Error code appears on the display and the multicooker beeps continuously.	C1 C3 C4 C6	Faulty sensor.	Contact <b>Customer Care</b> .
	C7	Heat element has failed.	Contact <b>Customer Care</b> .
		Not enough liquid.	Add thin, water-based liquid to the cooking pot according to its size. 500 mL
	C8	Incorrect cooking pot is used.	Only use a stainless-steel Pro Series cooking pot with easy grip handles with the Pro Plus.
	C10	Wifi error.	Contact <b>Customer Care</b> .
	Lid	The lid is not in the correct position for the selected programme.	Open and close the lid. Do not use a lid when using Sauté.
	Alt	The target temperature for safe canning was not reached.	Touch <b>Cancel</b> . Check that all seals are clean, positioned correctly, and undamaged. Make sure that you have at least 1 cup of water in the cooking pot before restarting. Do not pressure can at altitudes above 2000 m (6600 ft).
	Food burn	High temperature was detected at the bottom of the cooking pot; the multicooker automatically reduces the temperature to avoid overheating.	Starch deposits at the bottom of the cooking pot may have blocked heat dissipation. Turn the multicooker off, release pressure and inspect the bottom of the cooking pot.
PrSE	Pressure has accumulated during a non-pressure cooking Smart Programme.	Touch <b>Cancel</b> and Quick Release pressure.	

Any other servicing must be performed by an authorised representative.

# Warranty

Instant Brands (EMEA) Limited, Instant Brands (Ireland) Limited, and Instant Brands LLC (collectively the “Company”) warrant this appliance to be free from defects in workmanship and material, under normal household use, for a period of one (1) year from the date of original purchase. This Limited Warranty extends only to the original purchaser and use of the appliance in the UK and EU. This warranty does not cover appliance use outside of the UK and EU.

Proof of original purchase date and, if requested, return of your appliance is required to obtain service under this Limited Warranty. Provided that this appliance is operated and maintained in accordance with the written instructions included with the appliance (which are also available at [instantbrands.co.uk](http://instantbrands.co.uk)), the Company will, at its sole discretion, either: (i) repair defects in materials and workmanship; or (ii) replace the appliance. In the event the appliance is replaced, the Limited Warranty on the replacement appliance will expire 12 months from the date of original consumer purchase.

The Company is not responsible for shipping costs for warranty service.

## Limitation and Exclusions

Any modification or attempted modification to your appliance may interfere with the safe operation of the appliance and may result in serious injury and damage. Any modification or attempted modification to your appliance or any part thereof will void the warranty, unless such modification(s) or alteration(s) were expressly authorised by the Company.

This warranty does not cover (1) normal wear and tear; (2) damage resulting from negligent, unreasonable or misuse of the appliance, improper assembly or disassembly, use contrary to the operating instructions, failure to provide reasonable and necessary maintenance, Acts of God (such as fire, flood, hurricanes and tornadoes), or repair or alteration by anyone, unless expressly directed and authorised by the Company; and (3) repairs where your appliance is used for other than normal household use and in a manner contrary to published user or operator instructions.

To the extent permitted by applicable law, the liability of the Company, if any, for any allegedly defective appliance or part shall be limited to repair or replacement of the appliance or part thereof, and shall not exceed the purchase price of a comparable replacement appliance. Except as expressly provided herein and to the extent permitted by law, (1) the Company makes no warranties, conditions or representations, express or implied, usage, custom of trade or otherwise with respect to the appliance or parts covered by this warranty and (2) the Company shall not be responsible or liable for indirect, incidental or consequential damages arising out of or in connection with the use or performance of the appliance or damages with respect to any economic loss, loss of property, loss of revenues or profits, loss of enjoyment or use, costs of removal, installation or other consequential damages of any nature or kind.

You may have rights and remedies under applicable laws, which are in addition to any right or remedy which may be available under this limited warranty.

# Warranty

Please visit [instantbrands.co.uk/product-registration/](https://instantbrands.co.uk/product-registration/) to register your appliance. You will be asked to provide your name, your email address, the store name, date of purchase, model number and serial number (both of which are found on the appliance). This registration will enable us to keep you up-to-date with product developments and recipes, and contact you in the unlikely event of a product safety notification. By registering, you acknowledge that you have read and understood the instructions for use and warnings accompanying the appliance.

## Warranty Service

To obtain warranty service, please contact our Customer Care Department by creating a support ticket online at [instantbrands.co.uk/support/](https://instantbrands.co.uk/support/). If we are unable to resolve the problem, you may be asked to send your appliance to the Service Department for quality inspection. Instant Brands is not responsible for shipping costs related to warranty service. When returning your appliance, please include your name, mailing address, email address, phone number, and proof of the original purchase date as well as a description of the problem you are encountering with the appliance.

### Within the UK

Instant Brands (EMEA) Limited,  
1 Christchurch Way,  
Woking, Surrey,  
GU21 6JG, UK.

Email: [UKSupport@instantbrands.com](mailto:UKSupport@instantbrands.com)  
Telephone: +44 (0) 3331 230051

### Within the UK

Instant Brands (EMEA) Limited,  
1 Christchurch Way,  
Woking, Surrey,  
GU21 6JG, UK.

Email: [UKSupport@instantbrands.com](mailto:UKSupport@instantbrands.com)  
Telephone: +44 (0) 3331 230051

This warranty was last updated on 1 September 2019 for all products sold from [1 November 2019]. If your product comes with our older warranty version, your warranty will continue to be honoured.

## Recycling

This appliance complies with the WEEE Directive 2012/19/EU on the disposal of electrical and electronic equipment (WEEE). This appliance complies with the European directive for electromagnetic compatibility (EMC) 2014/30/EU and its revisions, as well as Low Voltage Directive (LVD) 2014/35/EU and its revisions. This marking indicates that this product should not be disposed of with other household waste throughout the UK and EU. To prevent possible harm to the environment or human health from uncontrolled waste disposal, recycle it responsibly to promote the sustainable re-use of material sources. To return your used device, please use the return and collection systems or contact Customer Care for further recycling and WEEE information.



Instant Brands (EMEA) Limited  
1 Christchurch Way, Woking, Surrey,  
GU21 6JG, UK

Instant Brands (Ireland) Limited  
Suite 6, Rineanna House,  
Shannon Free Zone, Shannon,  
Co Clare, Ireland, V14 CA36

**instantbrands.co.uk**

© 2022 Instant Brands LLC  
818-0119-31

INSTANT, INSTANT POT  
and INSTANT BRANDS  
are registered trademarks of  
Instant Brands Holdings Inc.