

Model: iBT330 IS - US English
 Size: 102 x 150 mm
 Mat'l: 85gsm, WF paper, 1C + 1C
 Color: Black text on white background
 Jan 13, 2025

*FRONT

*BACK

iHome

Model: iBT330

Splash Resistant PORTABLE SPEAKER

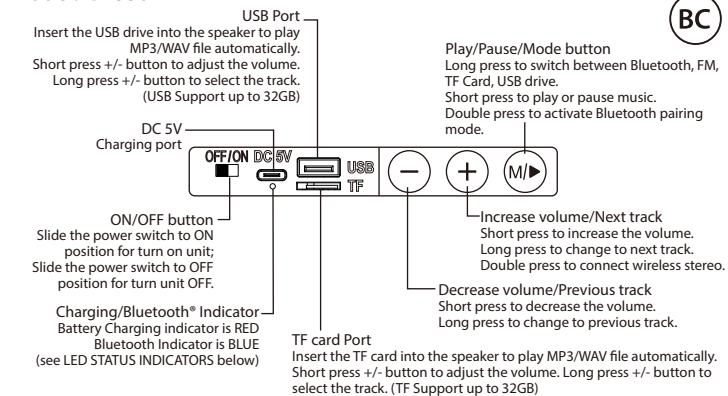

CHARGING THE SPEAKER

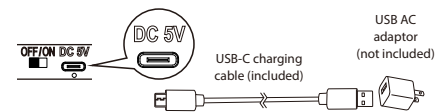

**CHARGE UNIT
BEFORE USE
ABOUT 4 HOURS**

LED STATUS INDICATORS

BATTERY CHARGING AND BLUETOOTH STATUS

*LED indicator located under USB-C port

Battery Indicator: A red light will glow steadily while the unit is charging and will turn off once fully charged. When the battery is low, it will automatically power off after announcing 'Low Battery' 3 times.

Bluetooth Indicator: In Bluetooth mode a blue light will flash while in pairing mode and glow steadily once connected.

FM RADIO OPERATION

In FM mode, short press the **M** button to search the FM stations automatically. If you need to stop searching, just short press again. The searched FM stations will be saved automatically.

Short press the **+** or **-** button to increase or decrease the volume. Long press the **+** or **-** button to select next or previous preset station.

Note: Please use the charging cable as FM antenna by connecting to the USB-C port to improve FM reception.

BLUETOOTH OPERATION

- The first time you power on the iBT330, it will enter Bluetooth pairing mode.
 - Select "iHome iBT330" on your device to pair.
 - To manually pair Bluetooth: Double press **M** button to manually search for BT pairing.
- Short press **▶** to play/pause Bluetooth music.
- Long press **+** button to next track; long press **-** button to previous track.

WIRELESS STEREO (REQUIRES 2 SPEAKERS)

- Pair one iBT330 unit to your device via Bluetooth.
- Power on the second iBT330 unit.
- Double press the **+** button on either speaker to connect wireless stereo.
- When both units are linked, will announce "Left Channel", "Right Channel" respectively.
- Both units will link automatically next time when both units are powered on.
- If want to remove Wireless Stereo: Double press **+** button again on **any one unit**.

BLUETOOTH FACTORY RESET OPERATION

Long press and hold **+** and **-** button for 3 seconds to reset.

For questions, warranty, and additional safety information, please visit:

<https://support.ihome.com/>

INTERNAL RECHARGEABLE LITHIUM-ION BATTERY

This device uses an internal non-replaceable rechargeable lithium-ion battery that should last the lifetime of the device. If you suspect your battery may be dead, try charging it for an extended period of time and try resetting the unit. Never leave a charging unit unattended. Always charge lithium devices on a non-flammable surface - wooden tables, bedding and carpeted floors are not recommended charging surfaces.

WARNING/DISPOSAL OF UNIT

Do NOT attempt to change the battery. Doing so will void the warranty and could cause injury and damage to your device. To dispose of the unit, follow the instructions below:

- Never dispose of used batteries/electronics with ordinary solid wastes, since they may contain toxic substances.
- Always dispose of used batteries/electronics in accordance with the prevailing community regulations.
- Many electronics retailers now recycle batteries and other electronic components at no charge. To find a drop-off location near you, visit www.call2recycle.com

GENERAL BATTERY PRECAUTIONS

- Never use or charge a battery if it appears to be leaking, discolored, deformed, or in any way abnormal.
- Never disassemble the unit or attempt to remove battery as that could cause leakage of alkaline solution or other electrolytic substances.
- Avoid charging a rechargeable battery when the temperature is not within 5°C - 35°C (41° - 95° Fahrenheit).
- Never expose a battery to any liquid.
- Never expose a battery to excessive heat such as direct sunlight or fire. Never use a battery pack in an unventilated vehicle where excessive internal temperatures may be encountered.
- Always keep batteries out of the reach of infants and small children.

IMPORTANT SAFETY INSTRUCTIONS

Please heed all warnings, read and follow all instructions and keep these instructions handy for future reference.

- Do not submerge this product in water.
- WARNING: To reduce the risk of fire or electric shock, do not expose this product to rain or moisture.
- Unplug unit and clean only with damp cloth. Stronger cleaning agents, such as Benzene, thinner or similar materials can damage the surface of the unit.
- Do not block any ventilation openings. Install in accordance with the manufacturer's instructions.
- Heat - This product should be situated away from heat sources such as radiators, heat registers, stoves or other appliances (including amplifiers) that produce heat.
- Only use attachments/accessories specified by the manufacturer.
- Unplug this product during lightning storms or when unused for long periods of time.
- Damage Requiring Service - This product should be serviced by qualified service personnel when:
 - Plug has been damaged.
 - Objects have fallen into or liquid has been spilled into the enclosure.
 - The unit has been exposed to rain. The unit has been dropped or the enclosure damaged.
 - The unit exhibits a marked change in performance or does not operate normally.
- No naked flame sources, such as lighted candles, should be placed on this product.
- Attention should be drawn to the environmental aspects of battery disposal.
- This product is suitable for use in tropical and/or moderate climates.

WARNING:

- Do not dispose of batteries in the household trash or fire.
- The mains plug of power adaptor is used as the disconnect device, it shall remain readily operable.
- If the unit is to be unused for an extended period of time, such as a month or longer, charge the unit fully before storage.
- Always use a UL/ETL certified charging adapter (not included), and the supplied USB charging cable.

FCC Information

This equipment complies with FCC RF radiation exposure limits set forth for an uncontrolled environment.

This device complies with Part 15 of the FCC Rules, operation is subject to the following two conditions:

- This device may not cause harmful interference, and (2) this device must accept any interference received, including interference that may cause undesired operation.
- Warning: Changes or modifications to this unit not expressly approved by the party responsible for compliance could void the user's authority to operate the equipment.
- NOTE: This equipment has been tested and found to comply with the limits for a Class B digital device, pursuant to Part 15 of the FCC Rules. These limits are designed to provide reasonable protection against harmful interference in a residential installation. This equipment generates, uses and can radiate radio frequency energy and, if not installed and used in accordance with the instructions, may cause harmful interference to radio communications. However, there is no guarantee that interference will not occur in a particular installation. If this equipment does cause harmful interference to radio or television reception, which can be determined by turning the equipment off and on, the user is encouraged to try to correct the interference by one or more of the following measures:
 - Reorient or relocate the receiving antenna.
 - Increase the separation between the equipment and receiver.
 - Connect the equipment into an outlet on a circuit different from that to which the receiver is connected.
 - Consult the dealer or an experienced radio/TV technician for help.

ISED Information

This equipment complies with IC RSS-102 radiation exposure limits set forth for an uncontrolled environment.

This device contains licence-exempt transmitter(s)/receiver(s) that comply with Innovation, Science and Economic Development Canada's licence-exempt RSS(s). Operation is subject to the following two conditions:

- This device may not cause interference.
 - This device must accept any interference, including interference that may cause undesired operation of the device.
- The device complies with ISED RF exposure requirement, users can obtain Canadian information on RF exposure and compliance. Any Changes or modifications not expressly approved by the party responsible for compliance could void the user's authority to operate the equipment. Cet équipement est conforme aux limites d'exposition aux radiations IC CNR-102 établies pour un environnement non contrôlé. L'émetteur/récepteur exempt de licence contenu dans le présent appareil est conforme aux CNR d'Innovation, Sciences et Développement économique Canada applicables aux appareils radio exempts de licence. L'exploitation est autorisée aux deux conditions suivantes :
- L'appareil ne doit pas produire de brouillage.
 - L'appareil doit accepter tout brouillage radioélectrique subi, même si le brouillage est susceptible d'en compromettre le fonctionnement.
- L'appareil est conforme aux exigences d'exposition RF ISED, les utilisateurs peuvent obtenir des informations canadiennes sur l'exposition aux RF et la conformité. Tout changement ou modification non expressément approuvé par la partie responsable de la conformité peut annuler l'autorité de l'utilisateur à utiliser l'équipement.

CAN ICES-3(B) / NMB-3(B)



© 2025 SDI Technologies, Inc.
All rights reserved

iBT330-011325-A

Printed in China